

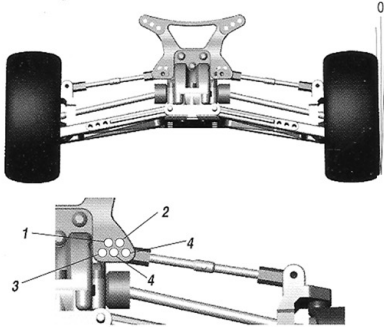

Name: _____	Date: _____	Event: _____	Track Conditions	
City: _____	State: _____	Track: _____	Time _____	Air Temp _____
Country: _____	Qualified: _____	Finish: _____	: _____ am	°F or °C _____
E-mail: _____	Best Lap Time / sec : _____	Avg. Lap Time / sec : _____	<input type="checkbox"/> Indoor	<input type="checkbox"/> Tight
Phone: _____	Note: _____		<input type="checkbox"/> Outdoor	<input type="checkbox"/> Open
			Race Length (min) _____	
			<input type="checkbox"/> Hard Packed	<input type="checkbox"/> Low Bite
			<input type="checkbox"/> Loose	<input type="checkbox"/> Med Bite
			Surface Content _____	<input type="checkbox"/> High Bite

Front suspension



Ride Height _____
 Camber Angle _____ °
 Castor Block _____ °
 Toe-in/Toe-out _____ °
 Camber Rod Pos _____
 Sway Bar Thickness _____

Front shocks

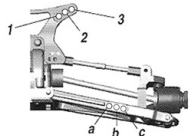

Piston _____
 Oil _____
 Spring _____
 Bladder Yes / No _____
 O-rings Above Bladder _____
 Shock position _____
 Limiting _____

Rear suspension

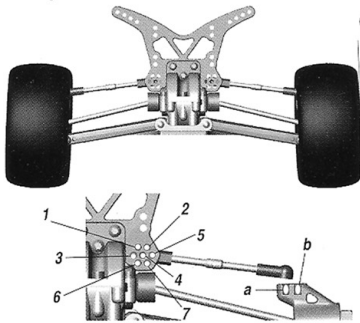

Ride Height _____
 Camber Angle _____ °
 Anti Squat Block _____ °
 Toe-in _____ °
 Shims Under Front Pivot _____
 Shims Under Rear Pivot _____
 Camber Rod Pos _____
 Sway Bar Thickness _____

Rear shocks

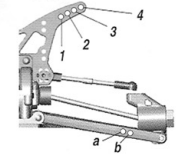

Piston _____
 Oil _____
 Spring _____
 Bladder Yes / No _____
 O-rings Above Bladder _____
 Shock position _____
 Limiting _____

Steering

Steering Link Position _____
 Ackerman Bar Length _____ mm
 Shims Under Stud _____
 Shims Under Stud _____

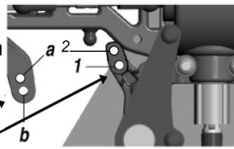

Front Drive

One Way
 Spool
 Differential



Motor _____ Servo _____
 Turns _____ ESC _____
 Brushes _____ Receiver _____
 Springs _____ Battery _____
 Timing _____ Transponder Location _____

Slipper

Yes No
 Length Of Slip in Feet _____
 One-Way On Center Shaft Yes No

Wing position

Wing _____
 Wing angle _____

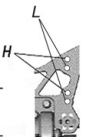

Weight Placement

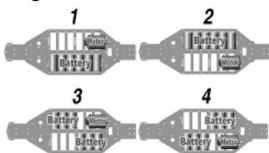

5. Other

Tires: Brand/Compound _____ Insert _____ Additive _____
 Front: _____
 Rear: _____

NOTES: _____ Spur Gear _____
 _____ Pinion Gear _____