

# set up sheet

Name : DEL COURT Jérôme  
 Date : 26 / 27 - 02 - 2005  
 Track : Championnat de France - Le Havre

**Track conditions**  
 Size :  Open  Med.  Tight  
 Traction :  High  Med.  Low  
 Surface :  Smooth  Bumpy

## Front suspension

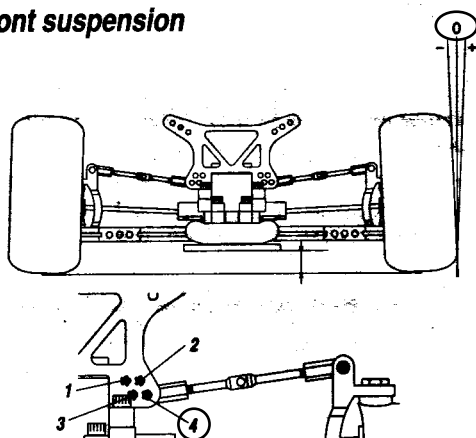

Ride height 10 mm  
 Camber angle 0 °  
 Caster angle 12° 9.5° 7°  
 Toe angle in/out 0 °  
 Rebound \_\_\_\_\_ mm  
 Upper arm position \_\_\_\_\_  
 Anti-roll bar \_\_\_\_\_ Ø

## Front shocks

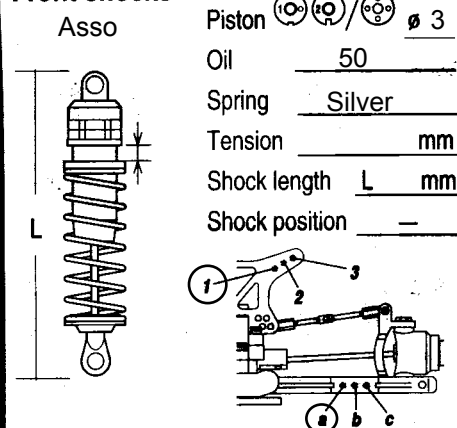

Asso  
 Piston Ø 3  
 Oil 50  
 Spring Silver  
 Tension \_\_\_\_\_ mm  
 Shock length L mm  
 Shock position \_\_\_\_\_

## Rear suspension

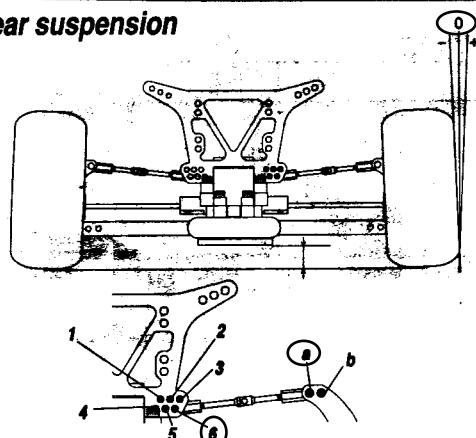

Ride height 10 mm  
 Camber angle 0 °  
 Anti-squat \_\_\_\_\_ °  
 Rebound \_\_\_\_\_ mm  
 Upper arm position \_\_\_\_\_  
 Anti-roll bar \_\_\_\_\_ Ø  
 Toe angle 2° \_\_\_\_\_ °

## One way

Center  
 Yes  No

## Rear shocks

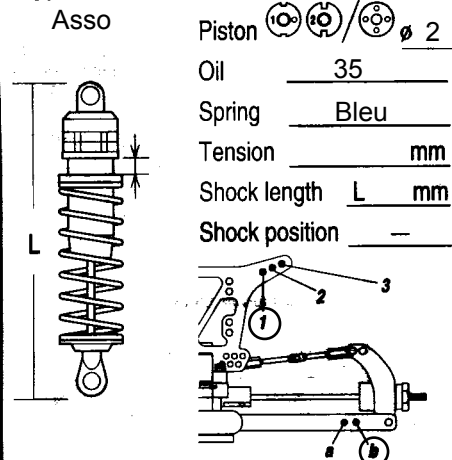

Asso  
 Piston Ø 2  
 Oil 35  
 Spring Bleu  
 Tension \_\_\_\_\_ mm  
 Shock length L mm  
 Shock position \_\_\_\_\_

## Steering

Steering rink position \_\_\_\_\_  
 Steering servo \_\_\_\_\_  
 Steering speed \_\_\_\_\_ %  
 Steering curve \_\_\_\_\_ %

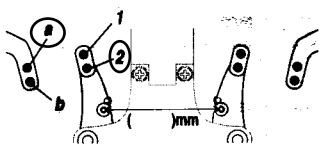

## Wing

Wing Academy  
 Wing angle 0

## Slipper

Yes  No

## Tires & Wheels

Front  
 Tire Schum Mini Pin Jaune  
 Insert \_\_\_\_\_  
 Wheel Origine

Rear  
 Tire Schum Mini Pin Jaune  
 Insert \_\_\_\_\_  
 Wheel Origine

## Result

Race time / Lap \_\_\_\_\_  
 Best lap (1Lap) \_\_\_\_\_

Motor 12 T/ 2 Brake \_\_\_\_\_ %

ESC Novak ABS  Yes  No

Battery Reedy 3300 mA Matched  Yes  No

Drive ratio S 70 T/P 18 T x 2.75 = 10.69

## Comments

## Overall drive ratio

Pinion	Spur	62T	65T	67T	70T	72T
16T						12.375
17T						11.645
18T					10.69	11.00
19T					10.13	10.42
20T					9.62	9.90
21T				8.77	9.16	9.42
22T				8.375	8.75	9.00
23T			7.77	8.01	8.36	8.60
24T			7.44	7.67	8.02	8.25
25T			7.15	7.37	7.70	7.92
26T			6.87	7.08	7.40	7.61
27T	6.31	6.62	6.82	7.12	7.33	
28T	6.08	6.38	6.58	6.87	7.07	
29T	5.87	6.16	6.35	6.63	6.82	
30T	5.68	5.95	6.14	6.14	6.60	