

SET-UP SHEET

XRAY T4

| | | | |
|----------------|-----------------|---------|--|
| RACE | SM Lauf | | |
| TRACK | RCSF Singen | | |
| NAME | Marco B | | |
| CITY / COUNTRY | Erisdorf | Germany | |
| CONTACT | marco-rc@gmx.de | | |

| | | | | |
|---------------------|------------|------------------------|----------------------|-------|
| DATE | 30/11/2012 | TEMPERATURE / °F or °C | AIR | TRACK |
| QUALIFYING POSITION | 2 | BEST LAPTIME /sec | FINAL POSITION | 8 |
| | | | RACE LENGTH /minutes | 5 |

| | | |
|-----------------|--|--|
| TRACK CONDITION | <input checked="" type="checkbox"/> CARPET | <input type="checkbox"/> ASPHALT |
| | <input type="checkbox"/> TECHNICAL | <input type="checkbox"/> FAST |
| TRACTION | <input type="checkbox"/> LOW | <input checked="" type="checkbox"/> MEDIUM |
| | | <input type="checkbox"/> HIGH |

| FRONT | REAR |
|--------------|------|
| TRANSMISSION | |

| | | | |
|----------------------|---|-------------------|---|
| SOLID AXLE | <input checked="" type="checkbox"/> YES | BALL DIFFERENTIAL | <input type="checkbox"/> YES |
| SOLID ONE WAY DIFF. | <input type="checkbox"/> YES | | |
| ONE WAY DIFFERENTIAL | <input type="checkbox"/> YES | | |
| GEAR DIFFERENTIAL | <input type="checkbox"/> YES | GEAR DIFFERENTIAL | <input checked="" type="checkbox"/> YES |
| OIL | | OIL | 2000 /cst |

| | | | |
|-------------------|-----------------|---------------|-----|
| PINION / T | 17 | SPUR GEAR / T | 84 |
| FINAL DRIVE RATIO | 4.9411764705882 | ROLLOUT | NaN |

| FRONT | REAR |
|-------|------|
|-------|------|

| | | |
|---------------|--------------|---------------|
| T Shox Yellow | XRAY SPRINGS | T Shox Yellow |
| MM45 | OIL / CST | MM45 |
| | LENGTH /mm | |
| | PRELOAD /mm | |
| | REBOUND % | |

| | | | | |
|------------------------------|-----------------------------|-----------------|------------------------------|-----------------------------|
| <input type="checkbox"/> YES | <input type="checkbox"/> NO | FOAM INSERTS | <input type="checkbox"/> YES | <input type="checkbox"/> NO |
| <input type="checkbox"/> YES | <input type="checkbox"/> NO | O-RING ON SHAFT | <input type="checkbox"/> YES | <input type="checkbox"/> NO |

| | | | | | |
|----------------------------------|---|---------|-------|---|---|
| <input type="checkbox"/> 3 HOLES | <input checked="" type="checkbox"/> 4 HOLES | PISTONS | 1.0mm | <input type="checkbox"/> 3 HOLES | <input type="checkbox"/> 4 HOLES |
| | | | 1.1mm | <input checked="" type="checkbox"/> 3 HOLES | <input checked="" type="checkbox"/> 4 HOLES |
| | | | 1.2mm | <input type="checkbox"/> 3 HOLES | <input checked="" type="checkbox"/> 4 HOLES |
| | | OTHERS | | | |

| | | | | |
|-----|--------------|---------------|--------------|-----|
| 1,4 | THICKNESS/mm | ANTI-ROLL BAR | THICKNESS/mm | 1,2 |
|-----|--------------|---------------|--------------|-----|

| | | |
|---------|-----------------|---------|
| LRP CPX | TIRES | LRP CPX |
| | INSERTS | |
| | ADDITIVE | |
| 20 | ADDITIVE TIMING | 30 |

| | | | |
|--------------|-------------|-----------|------------|
| FRONT LEFT | FRONT RIGHT | REAR LEFT | REAR RIGHT |
| | | | |
| TREATED AREA | | | |

| WHEELS | | | |
|--------------------------|--------------------------|--------------------------|--|
| S | M | H | |
| <input type="checkbox"/> | <input type="checkbox"/> | <input type="checkbox"/> | |
| HARDNESS | | | |
| S | M | H | |
| <input type="checkbox"/> | <input type="checkbox"/> | <input type="checkbox"/> | |

| | | | |
|-------|-------------|----------|--|
| MOTOR | ORCA TX 4,5 | TIMING | |
| ROTOR | | ARMATURE | |

| | | | |
|-----|---------|-----------|------|
| ESC | Orca VX | BATTERIES | Orca |
|-----|---------|-----------|------|

| | | | |
|------|--|------|--|
| BODY | | WING | |
|------|--|------|--|

● - APPLIED S-SOFT M-MEDIUM H-HARD

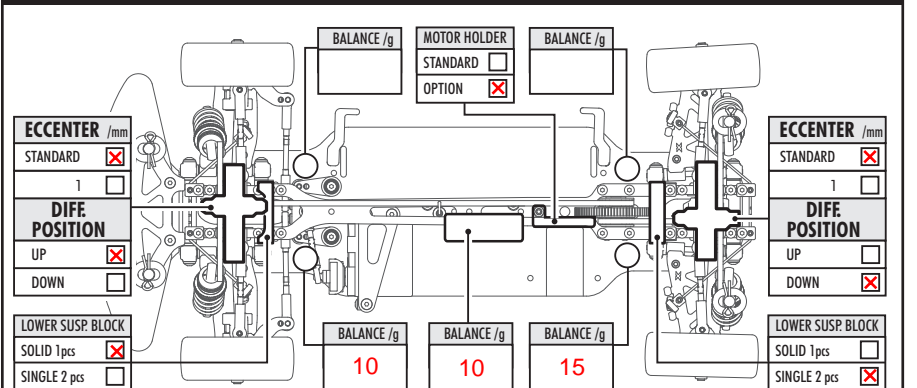
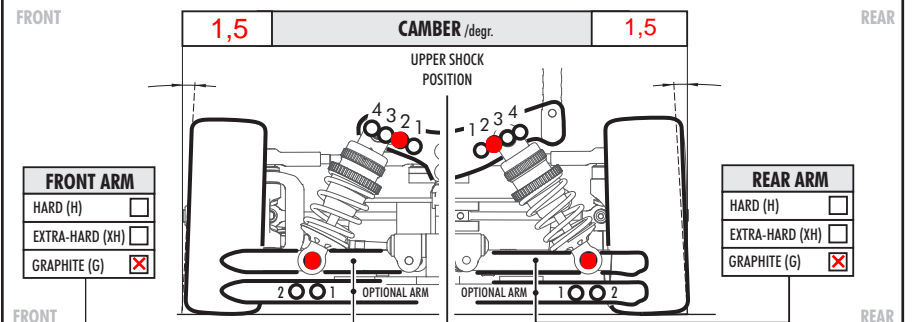
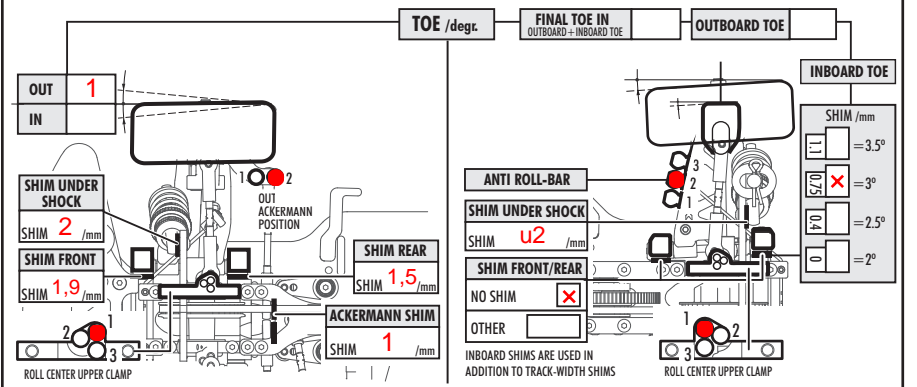
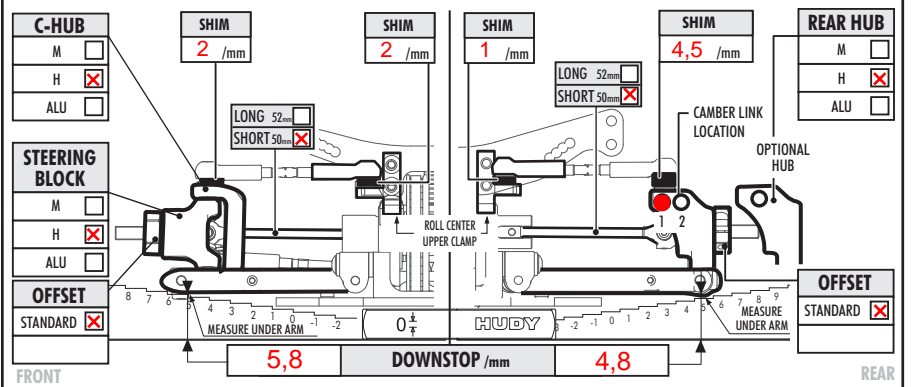
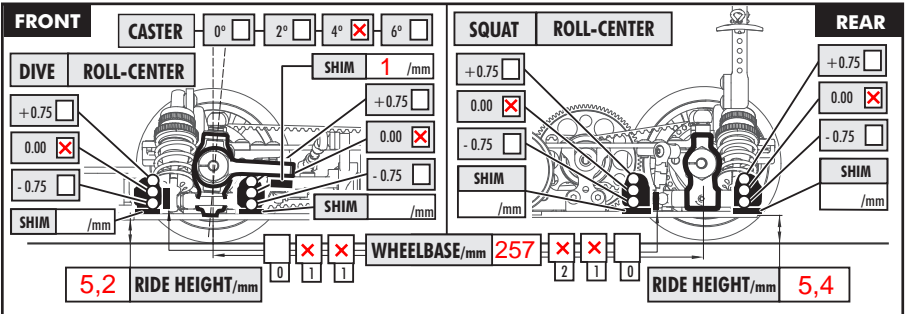

COMMENTS