

SET-UP SHEET

XRAY T4

| | |
|----------------|--------------|
| RACE | GP3F |
| TRACK | |
| NAME | Alex LAURENT |
| CITY / COUNTRY | France |
| CONTACT | |

| | | | | | | |
|------|---------------|------------------------|-----|------|-------|------|
| DATE | 15-16/12/2012 | TEMPERATURE / °F or °C | AIR | 21°C | TRACK | 21°C |
|------|---------------|------------------------|-----|------|-------|------|

| | | | |
|---------------------|-------------------|----------------|----------------------|
| QUALIFYING POSITION | BEST LAPTIME /sec | FINAL POSITION | RACE LENGTH /minutes |
| 10th | 12"05 | 9th | 5 min |

| | | | |
|------------------------------------|--|--|-------------------------------|
| TRACK CONDITION | <input checked="" type="checkbox"/> CARPET | <input type="checkbox"/> ASPHALT | |
| <input type="checkbox"/> TECHNICAL | <input checked="" type="checkbox"/> MIXED | <input type="checkbox"/> FAST | |
| TRACTION | <input type="checkbox"/> LOW | <input checked="" type="checkbox"/> MEDIUM | <input type="checkbox"/> HIGH |

| FRONT | REAR |
|--------------|------|
| TRANSMISSION | |

| | | | |
|----------------------|---|-------------------|------------------------------|
| SOLID AXLE | <input checked="" type="checkbox"/> YES | BALL DIFFERENTIAL | <input type="checkbox"/> YES |
| SOLID ONE WAY DIFF. | <input type="checkbox"/> YES | | |
| ONE WAY DIFFERENTIAL | <input type="checkbox"/> YES | | |

| | | | |
|-------------------|------------------------------|-------------------|---|
| GEAR DIFFERENTIAL | <input type="checkbox"/> YES | GEAR DIFFERENTIAL | <input checked="" type="checkbox"/> YES |
| OIL | | OIL | 2000 /Cst |

| | | | |
|-------------------|------|---------------|-----|
| PINION / T | 24 | SPUR GEAR / T | 110 |
| FINAL DRIVE RATIO | 8.71 | PITCH | |

| FRONT | REAR | |
|-------|--------------|-----|
| 2.7 | XRAY SPRINGS | 2.5 |
| 350 | OIL / CST | 350 |
| 9 | LENGTH /mm | 9 |
| 2 | PRELOAD /mm | 2 |
| 25 | REBOUND % | 25 |

| | | | | |
|------------------------------|--|-----------------|------------------------------|--|
| <input type="checkbox"/> YES | <input checked="" type="checkbox"/> NO | FOAM INSERTS | <input type="checkbox"/> YES | <input checked="" type="checkbox"/> NO |
| <input type="checkbox"/> YES | <input checked="" type="checkbox"/> NO | O-RING ON SHAFT | <input type="checkbox"/> YES | <input checked="" type="checkbox"/> NO |

| | | | | | |
|----------------------------------|---|---------|-------|----------------------------------|---|
| <input type="checkbox"/> 3 HOLES | <input checked="" type="checkbox"/> 4 HOLES | PISTONS | 1.0mm | <input type="checkbox"/> 3 HOLES | <input checked="" type="checkbox"/> 4 HOLES |
| | | | 1.1mm | | |
| | | | 1.2mm | | |
| | | OTHERS | | | |

| | | | | |
|-----|--------------|---------------|--------------|-----|
| 1.4 | THICKNESS/mm | ANTI-ROLL BAR | THICKNESS/mm | 1.2 |
|-----|--------------|---------------|--------------|-----|

| | | |
|-------|-----------------|-------|
| CPX30 | TIRES | CPX30 |
| LRP | INSERTS | LRP |
| 30min | ADDITIVE | 30min |
| | ADDITIVE TIMING | |

| | | | |
|--------------|-------------|-----------|------------|
| FRONT LEFT | FRONT RIGHT | REAR LEFT | REAR RIGHT |
| | | | |
| TREATED AREA | | | |

| WHEELS | | | | | | |
|--------------------------|--------------------------|--------------------------|----------|---|---|--------------------------|
| S | M | H | HARDNESS | | | |
| <input type="checkbox"/> | <input type="checkbox"/> | <input type="checkbox"/> | S | M | H | <input type="checkbox"/> |

| | | | |
|-------|------------|----------|--|
| MOTOR | NOSRAM 4.5 | TIMING | |
| ROTOR | | ARMATURE | |

| | | | |
|-----|--------------|-----------|--------|
| ESC | NOSRAM COMET | BATTERIES | NOSRAM |
|-----|--------------|-----------|--------|

| | | | |
|------|---------------------|------|----|
| BODY | PF MAZDA SPEED 6 LW | WING | PF |
|------|---------------------|------|----|

APPLIED S: SOFT M: MEDIUM H: HARD

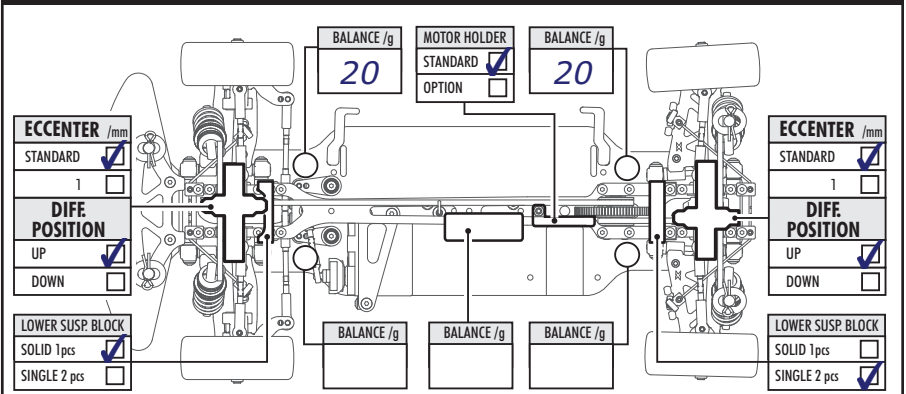
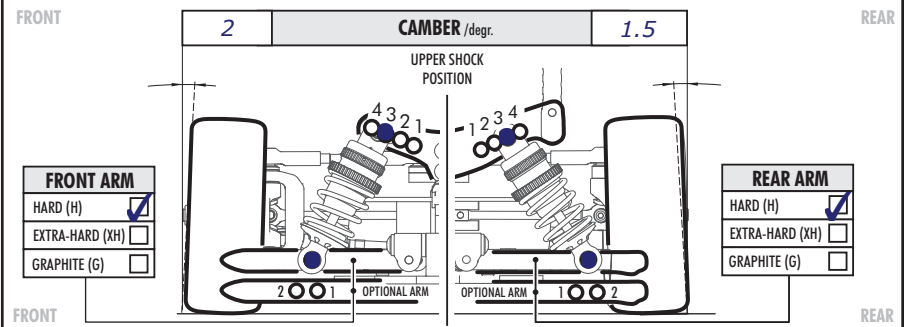
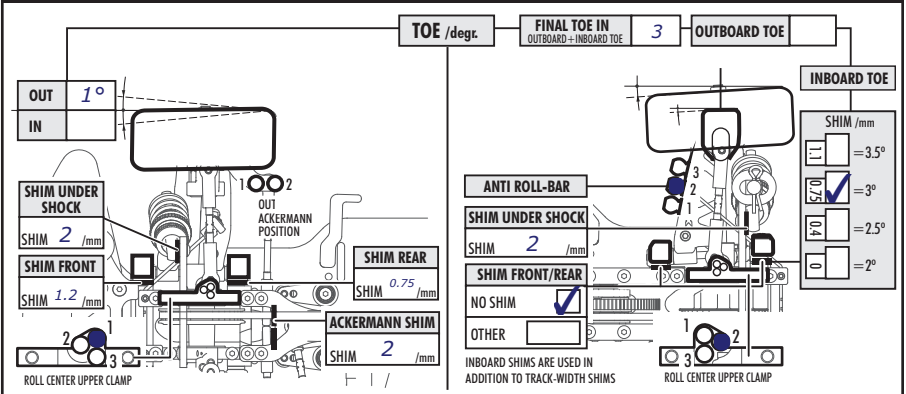
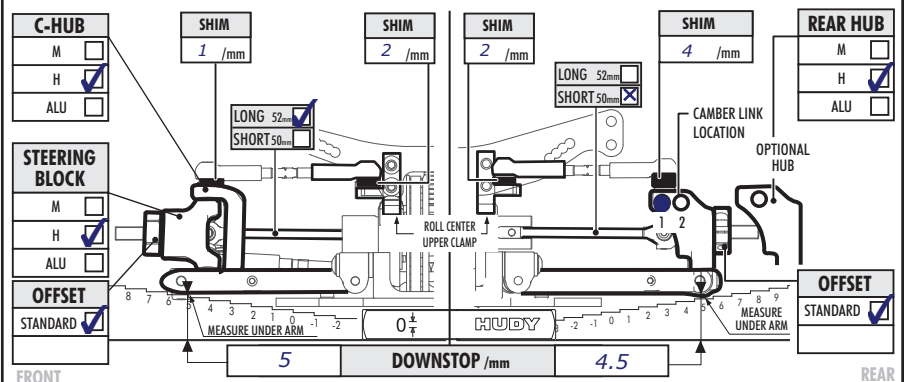
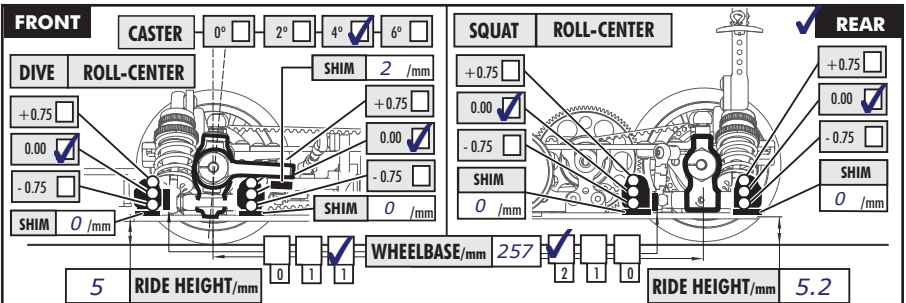

COMMENTS

Alterations by Arn0 at PetitRC.com