

SET-UP SHEET

XRAY T4

RACE	ETS Final Starting Set-up		
TRACK	HUDY Racing Arena Outdoor		
NAME	Alexander Hagberg		
CITY / COUNTRY	Trencin	Slovakia	
CONTACT	alexander.hagberg@gmail.com		

DATE	11/07/2013	TEMPERATURE / °F or °C	AIR	TRACK
QUALIFYING POSITION	BEST LAPTIME /sec	FINAL POSITION	RACE LENGTH /minutes	

TRACK CONDITION	<input type="checkbox"/> CARPET	<input checked="" type="checkbox"/> ASPHALT	
<input type="checkbox"/> TECHNICAL	<input type="checkbox"/> MIXED	<input checked="" type="checkbox"/> FAST	
TRACTION	<input type="checkbox"/> LOW	<input checked="" type="checkbox"/> MEDIUM	<input type="checkbox"/> HIGH

FRONT		REAR	
TRANSMISSION			
SOLID AXLE	<input type="checkbox"/> YES	BALL DIFFERENTIAL	<input type="checkbox"/> YES
SOLID ONE WAY DIFF.	<input type="checkbox"/> YES		
ONE WAY DIFFERENTIAL	<input type="checkbox"/> YES		
GEAR DIFFERENTIAL	<input checked="" type="checkbox"/> YES	GEAR DIFFERENTIAL	<input type="checkbox"/> YES
OIL	putty	OIL	3000 /cst
PINION / T	28	SPUR GEAR / T	112
FINAL DRIVE RATIO	4	ROLLOUT	NaN

FRONT		REAR	
2.5-2.8	XRAY SPRINGS	2.5	
350	OIL / CST	350	
	LENGTH /mm		
	PRELOAD /mm		
0	REBOUND %	0	

<input type="checkbox"/> YES	<input checked="" type="checkbox"/> NO	FOAM INSERTS	<input type="checkbox"/> YES	<input checked="" type="checkbox"/> NO
<input type="checkbox"/> YES	<input checked="" type="checkbox"/> NO	O-RING ON SHAFT	<input type="checkbox"/> YES	<input checked="" type="checkbox"/> NO
<input type="checkbox"/> 3 HOLES	<input checked="" type="checkbox"/> 4 HOLES	PISTONS	<input type="checkbox"/> 3 HOLES	<input checked="" type="checkbox"/> 4 HOLES
		1.0mm		
		1.1mm		
		1.2mm		
		OTHERS		

1.3	THICKNESS/mm	ANTI-ROLL BAR	THICKNESS/mm	1.2
Ride Rex 34	TIRES	Ride Rex 34		
AME	INSERTS	AME		
20	ADDITIVE	20		
	ADDITIVE TIMING			

<input type="checkbox"/> 3 HOLES	<input checked="" type="checkbox"/> 4 HOLES	<input type="checkbox"/> 3 HOLES	<input checked="" type="checkbox"/> 4 HOLES

1.3	THICKNESS/mm	ANTI-ROLL BAR	THICKNESS/mm	1.2
Ride Rex 34	TIRES	Ride Rex 34		
AME	INSERTS	AME		
20	ADDITIVE	20		
	ADDITIVE TIMING			

FRONT LEFT	FRONT RIGHT	REAR LEFT	REAR RIGHT
TREATED AREA			

S <input type="checkbox"/>	M <input type="checkbox"/>	H <input type="checkbox"/>	WHEELS	S <input type="checkbox"/>	M <input type="checkbox"/>	H <input type="checkbox"/>
			HARDNESS			

MOTOR	ORCA TX 4.5T	TIMING	STD
ROTOR	12.5	ARMATURE	
ESC	ORCA VX	BATTERIES	ORCA 6000
BODY	LTC-R LW	WING	Hard

● - APPLIED S-SOFT M-MEDIUM H-HARD

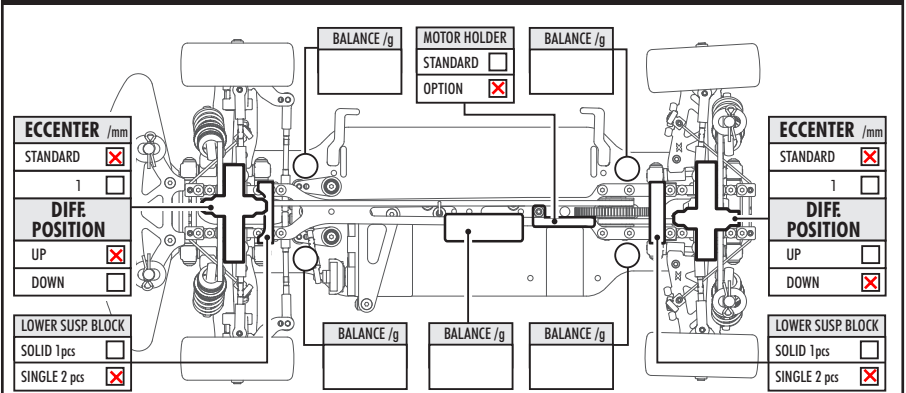
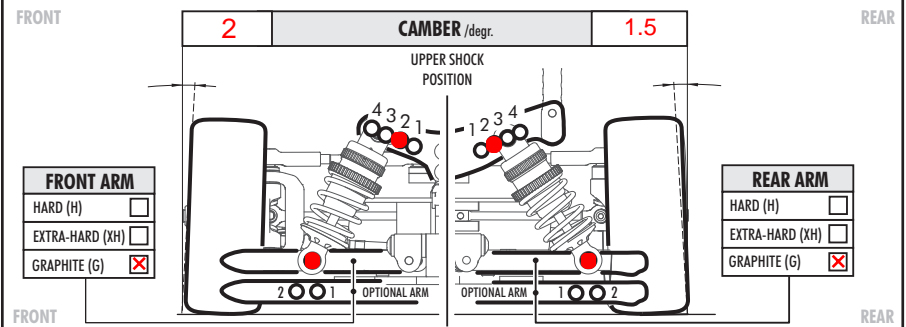
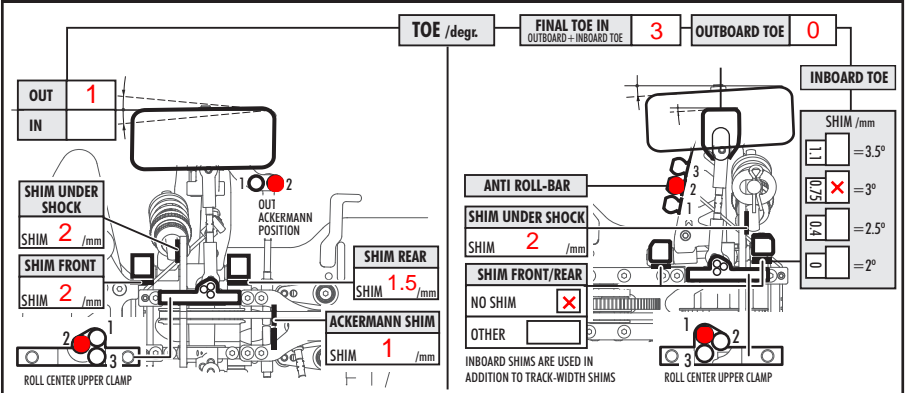
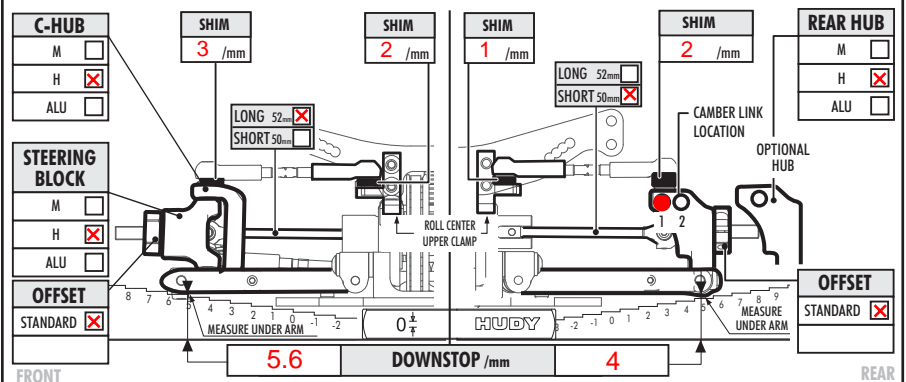
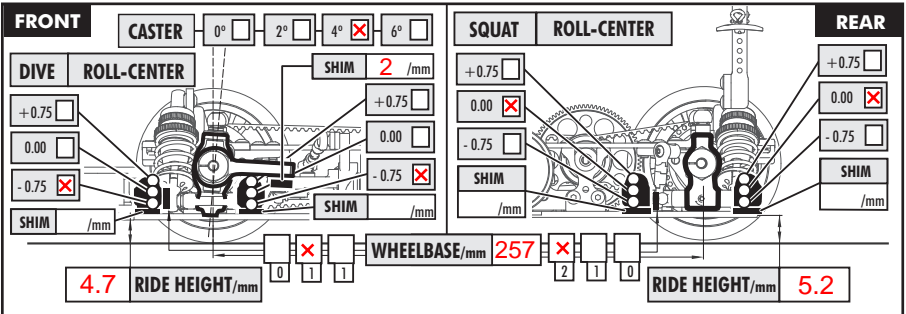

COMMENTS

HUDY alu servo horn

1.6 topdeck

ECS front driveshafts