

SET-UP SHEET

XRAY T4'14

RACE	Practice		
TRACK	Weil der Stadt		
NAME	Timi		
CITY / COUNTRY	Stuttgart	Germany	
CONTACT			

DATE	17/11/2013	TEMPERATURE / °F or °C	AIR 18	TRACK	-
------	------------	------------------------	--------	-------	---

QUALIFYING POSITION	BEST LAPTIME /sec	FINAL POSITION	RACE LENGTH /minutes
-	8.971	-	-

TRACK CONDITION	<input checked="" type="checkbox"/> TECHNICAL	<input checked="" type="checkbox"/> CARPET	<input type="checkbox"/> ASPHALT
	<input type="checkbox"/> MIXED	<input type="checkbox"/> FAST	
TRACTION	<input type="checkbox"/> LOW	<input checked="" type="checkbox"/> MEDIUM	<input type="checkbox"/> HIGH

FRONT	REAR
TRANSMISSION	

SOLID AXLE	<input checked="" type="checkbox"/> YES	BALL DIFFERENTIAL	<input type="checkbox"/> YES
SOLID ONE WAY DIFF.	<input type="checkbox"/> YES		
ONE WAY DIFFERENTIAL	<input type="checkbox"/> YES		

GEAR DIFFERENTIAL	<input type="checkbox"/> YES	GEAR DIFFERENTIAL	<input checked="" type="checkbox"/> YES
OIL		OIL	6000 /Cst

PINION / T	24	SPUR GEAR / T	114
FINAL DRIVE RATIO	9.025	ROLLOUT	NaN

FRONT	REAR
-------	------

2.5-2.8	XRAY SPRINGS	2.5-2.8
---------	--------------	---------

400	OIL / CST	400
-----	-----------	-----

	LENGTH /mm	
--	------------	--

	PRELOAD /mm	
--	-------------	--

20%	REBOUND %	20%
-----	-----------	-----

<input checked="" type="checkbox"/> YES	<input type="checkbox"/> NO	FOAM INSERTS	<input checked="" type="checkbox"/> YES	<input type="checkbox"/> NO
<input type="checkbox"/> YES	<input checked="" type="checkbox"/> NO	O-RING ON SHAFT	<input type="checkbox"/> YES	<input checked="" type="checkbox"/> NO

<input checked="" type="checkbox"/> 3 HOLES	<input type="checkbox"/> 4 HOLES	PISTONS	<input type="checkbox"/> 3 HOLES	<input checked="" type="checkbox"/> 4 HOLES
		1.0mm		
		1.1mm		
		1.2mm		
OTHERS				

1.4	THICKNESS/mm	ANTI-ROLL BAR	THICKNESS/mm	1.4
-----	--------------	---------------	--------------	-----

Vtec CPX	TIRES	Vtec CPX
std.	INSERTS	std.

LRp C3	ADDITIVE	LRP C3
15	ADDITIVE TIMING	15

FRONT LEFT	FRONT RIGHT	REAR LEFT	REAR RIGHT
TREATED AREA			

std.	WHEELS	std.
<input type="checkbox"/> S	HARDNESS	<input type="checkbox"/> S
<input type="checkbox"/> M		<input type="checkbox"/> M
<input type="checkbox"/> H		<input type="checkbox"/> H

MOTOR	4.5T	TIMING	blinky
ROTOR	std.	ARMATURE	ORCA

ESC	ORCA	BATTERIES	ORCA 6000
-----	------	-----------	-----------

BODY	Mazda lw - std. Positon	WING	MR33
------	-------------------------	------	------

- APPLIED S-SOFT M-MEDIUM H-HARD

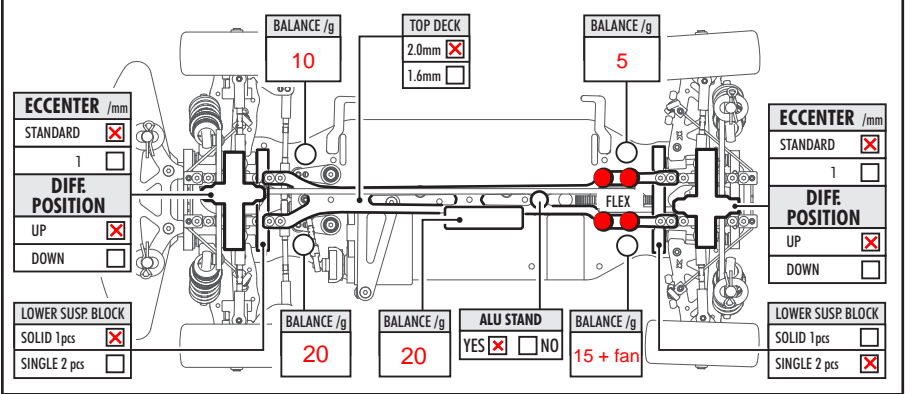
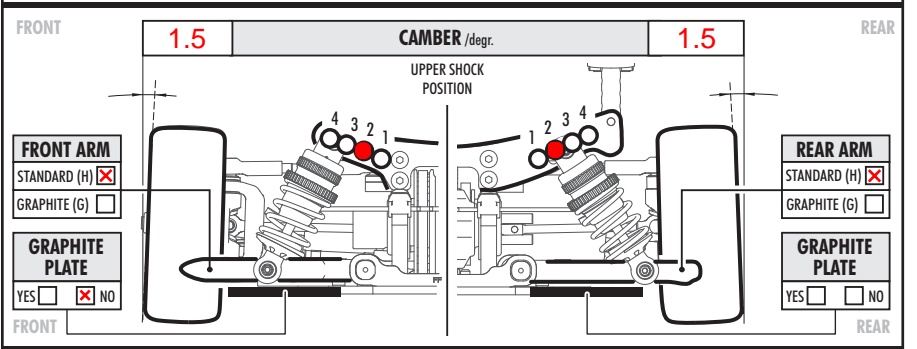
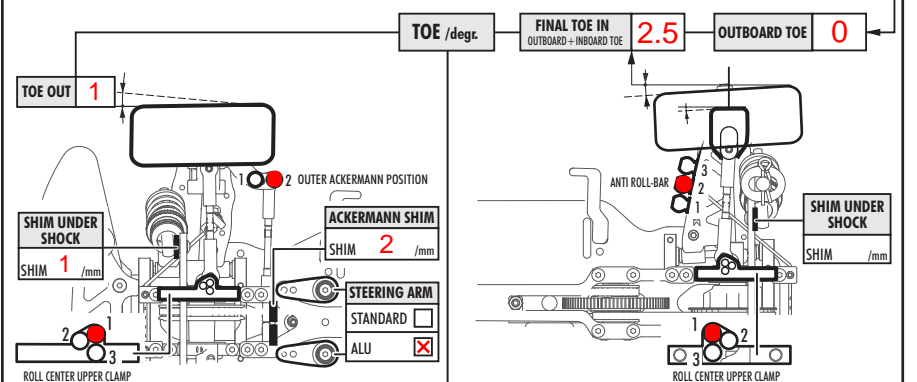
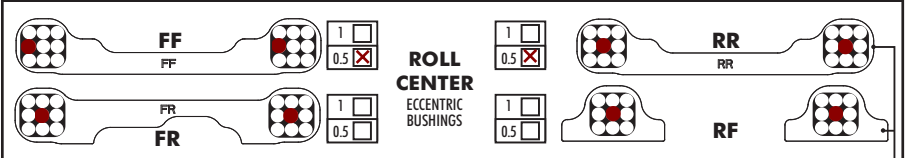
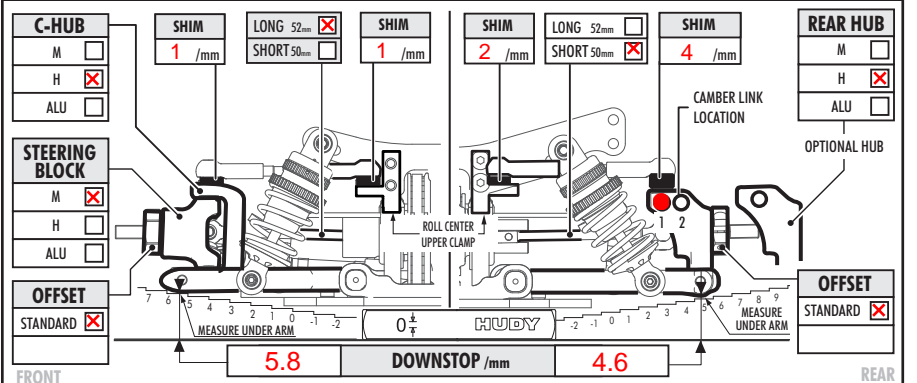
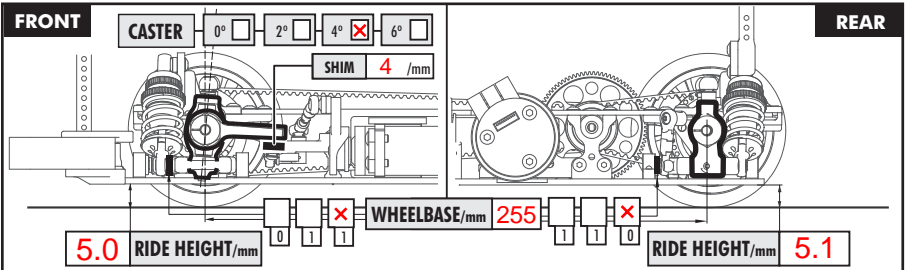

COMMENTS

- Hudy Servoarm
- Serpenishim at the Steerin - maximum Steering
- used CPX Tires
- Battery Voltage: 8.04V
- ECS Driveshaft front
- Alu-Stand used but without down screw