

SET-UP SHEET

XRAY T4'14

| | | | |
|----------------|------------------------|----------------|--|
| RACE | ETS Luxembourg | | |
| TRACK | Luxembourg | | |
| NAME | Anonymous | | |
| CITY / COUNTRY | Kromeriz | Czech Republic | |
| CONTACT | marekcerny2@centrum.cz | | |

| | | | | | | |
|------|------------|------------------------|-----|----|-------|----|
| DATE | 25/06/2014 | TEMPERATURE / °F or °C | AIR | 25 | TRACK | 30 |
|------|------------|------------------------|-----|----|-------|----|

| | | | |
|---------------------|-------------------|----------------|----------------------|
| QUALIFYING POSITION | BEST LAPTIME /sec | FINAL POSITION | RACE LENGTH /minutes |
| 1 | - | 1 | 5 |

| | | | |
|------------------------------------|---------------------------------|---|-------------------------------|
| TRACK CONDITION | <input type="checkbox"/> CARPET | <input checked="" type="checkbox"/> ASPHALT | |
| <input type="checkbox"/> TECHNICAL | <input type="checkbox"/> MIXED | <input checked="" type="checkbox"/> FAST | |
| TRACTION | <input type="checkbox"/> LOW | <input checked="" type="checkbox"/> MEDIUM | <input type="checkbox"/> HIGH |

| FRONT | REAR |
|--------------|------|
| TRANSMISSION | |

| | | | |
|----------------------|------------------------------|-------------------|------------------------------|
| SOLID AXLE | <input type="checkbox"/> YES | BALL DIFFERENTIAL | <input type="checkbox"/> YES |
| SOLID ONE WAY DIFF. | <input type="checkbox"/> YES | | |
| ONE WAY DIFFERENTIAL | <input type="checkbox"/> YES | | |

| | | | |
|-------------------|------------------------------|-------------------|---|
| GEAR DIFFERENTIAL | <input type="checkbox"/> YES | GEAR DIFFERENTIAL | <input checked="" type="checkbox"/> YES |
| OIL | 100000 | OIL | 4000 /Cst |

| | | | |
|-------------------|-----------------|---------------|-----|
| PINION / T | 38 | SPUR GEAR / T | 90 |
| FINAL DRIVE RATIO | 2.3684210526316 | ROLLOUT | NaN |

| FRONT | REAR |
|-------|------|
|-------|------|

| | | |
|-----|--------------|-----|
| 2,7 | XRAY SPRINGS | 2,7 |
| 300 | OIL / CST | 350 |
| st | LENGTH /mm | st |
| 0 | PRELOAD /mm | 0 |
| 0 | REBOUND % | 0 |

| | | | | |
|------------------------------|--|-----------------|------------------------------|--|
| <input type="checkbox"/> YES | <input checked="" type="checkbox"/> NO | FOAM INSERTS | <input type="checkbox"/> YES | <input checked="" type="checkbox"/> NO |
| <input type="checkbox"/> YES | <input checked="" type="checkbox"/> NO | O-RING ON SHAFT | <input type="checkbox"/> YES | <input checked="" type="checkbox"/> NO |

| | | | | | |
|----------------------------------|---|---------|-------|----------------------------------|---|
| <input type="checkbox"/> 3 HOLES | <input checked="" type="checkbox"/> 4 HOLES | PISTONS | 1.0mm | <input type="checkbox"/> 3 HOLES | <input checked="" type="checkbox"/> 4 HOLES |
| | | | 1.1mm | | |
| | | | 1.2mm | | |
| OTHERS | | | | | |

| | | |
|--------------|---------------|--------------|
| THICKNESS/mm | ANTI-ROLL BAR | THICKNESS/mm |
|--------------|---------------|--------------|

| | |
|-----------------|--|
| TIRES | |
| INSERTS | |
| ADDITIVE | |
| ADDITIVE TIMING | |

| | | | |
|--------------|-------------|-----------|------------|
| FRONT LEFT | FRONT RIGHT | REAR LEFT | REAR RIGHT |
| | | | |
| TREATED AREA | | | |

| | | | |
|--------------------------|--------------------------|--------------------------|--|
| WHEELS | | | |
| S | M | H | |
| <input type="checkbox"/> | <input type="checkbox"/> | <input type="checkbox"/> | |
| HARDNESS | | | |
| S | M | H | |
| <input type="checkbox"/> | <input type="checkbox"/> | <input type="checkbox"/> | |

| | | | |
|-------|----------|----------|----|
| MOTOR | Muchmore | TIMING | st |
| ROTOR | st | ARMATURE | st |

| | | | |
|-----|-------|-----------|-----|
| ESC | Fleta | BATTERIES | LRP |
|-----|-------|-----------|-----|

| | | | |
|------|---------------|------|-------|
| BODY | Mazda SP 6 LW | WING | Blitz |
|------|---------------|------|-------|

● - APPLIED S - SOFT M - MEDIUM H - HARD

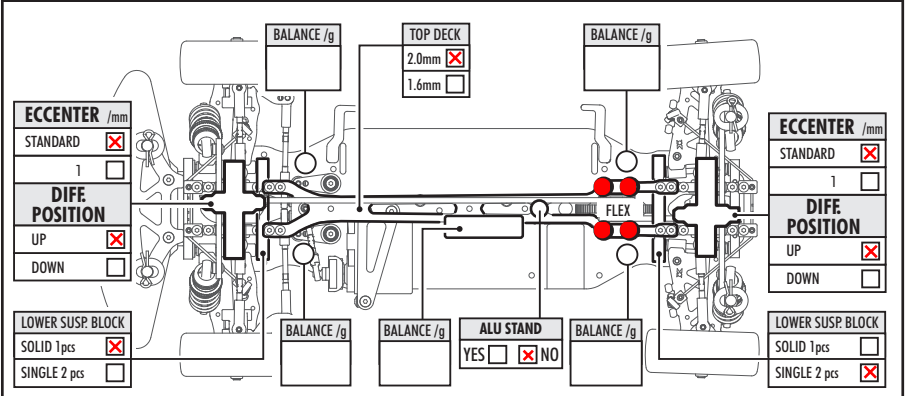
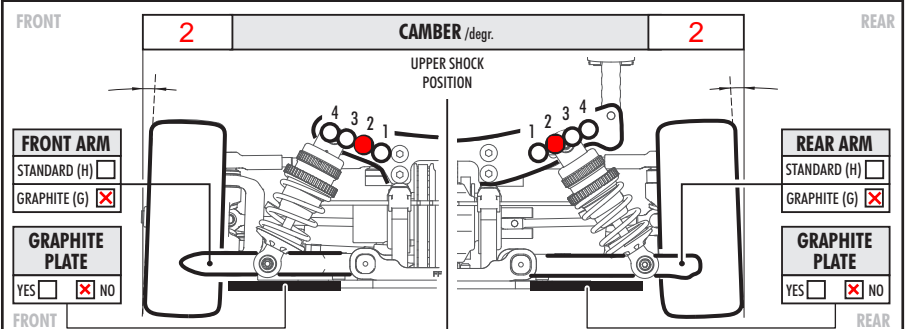
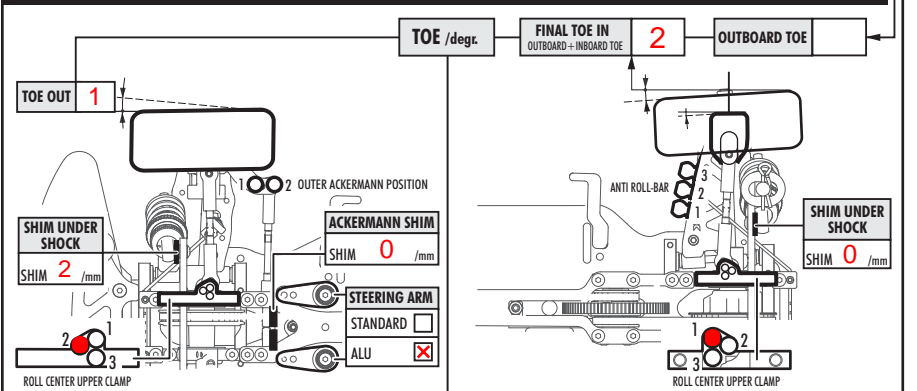
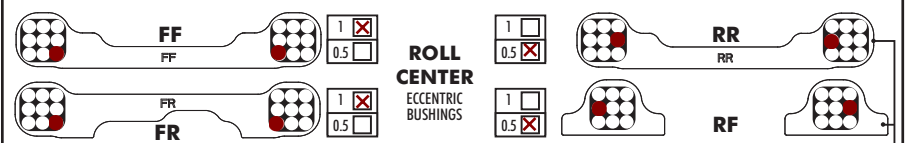
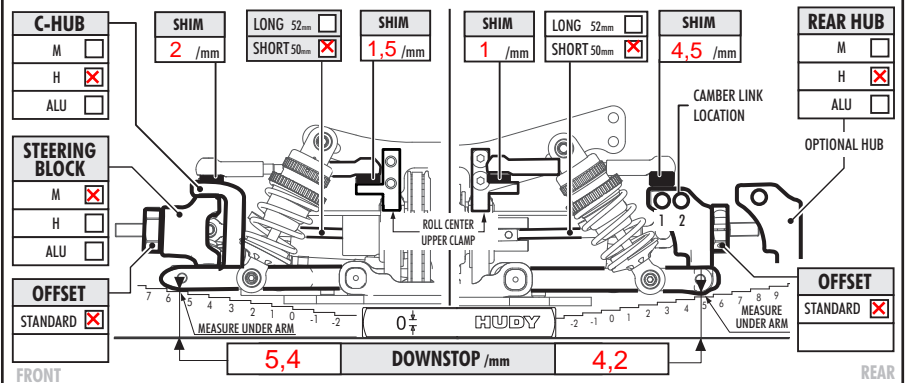
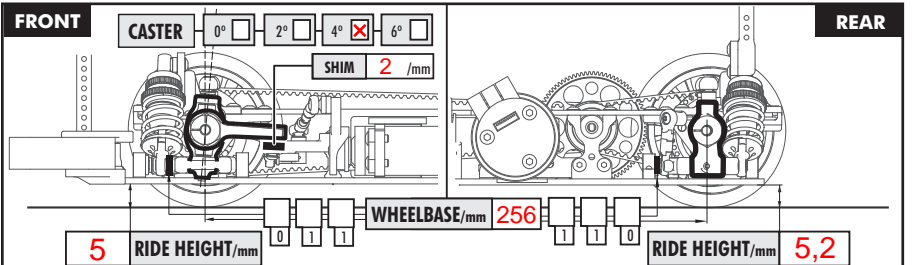

COMMENTS
ECS front