

SET-UP SHEET

XRAY X12

RACE	Practise 30.12.2012 - Copy	
TRACK	SYK	

NAME	Peakki	
CITY / COUNTRY	Seinajoki	Finland
CONTACT	peakki[at]nic.fi	

DATE	30/12/2012	
TEMPERATURE / <small>F or °C</small>	AIR	TRACK

QUALIFYING POSITION	BEST LAPTIME / sec	FINAL POSITION	RACE LENGTH / minutes
	9.05		

TRACK CONDITION	<input checked="" type="checkbox"/> CARPET	<input type="checkbox"/> ASPHALT
	<input type="checkbox"/> TECHNICAL	<input checked="" type="checkbox"/> MIXED
	<input checked="" type="checkbox"/> MEDIUM	<input type="checkbox"/> HIGH

CENTER SHOCK ABSORBER		
SPRING	black	OIL / cSt 600
		REBOUND%

SIDE LINKAGES	
OIL / cSt	ur 15k

FRONT	TIRES	REAR
MG magenta		
40	DIAMETER/mm	41,5
Robitronic	ADDITIVE	Robitronic
10	ADDITIVE timing	20

FRONT LEFT	FRONT RIGHT	ADDITIVE TREATED AREA	REAR LEFT	REAR RIGHT

TRANSMISSION	
DIFF SETTING	
<input type="checkbox"/> LOOSE	<input checked="" type="checkbox"/> MEDIUM
<input type="checkbox"/>	<input type="checkbox"/> TIGHT

PINION / T	21	SPUR GEAR/T	95
FINAL DRIVE RATIO	4.5238095238095	ROLLOUT	28.458315789474

MOTOR	
BRAND	Orion Vortex VST Pro
TURN	3.5T
ROTOR	std
TIMING	1mm

ESC	Orion R10 1S		
ESC SETTING	PROGRAM	stock boost	PUNCH 4
	INITIAL BRAKE	auto	AUTO BRAKE 0
BATTERIES	Reedy 6500		
BODY	PF AMR 12		

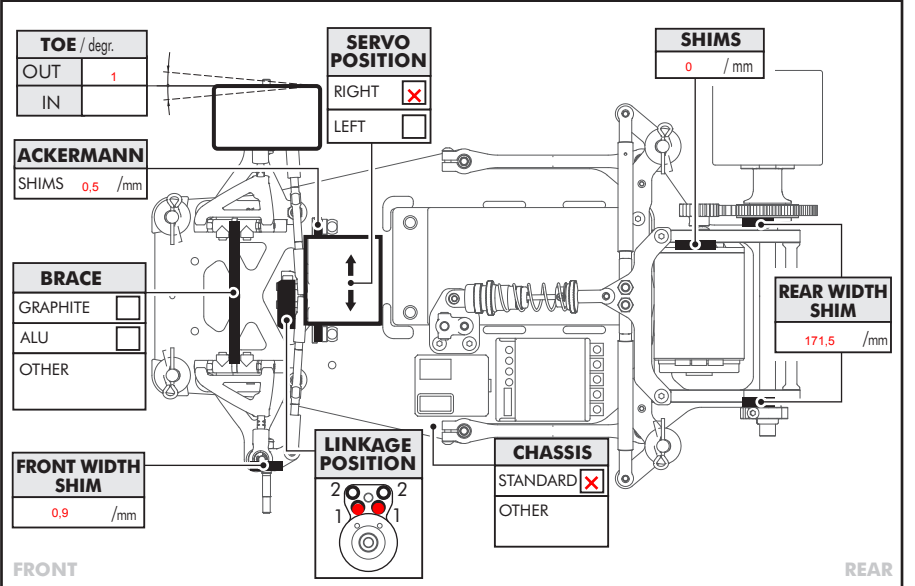
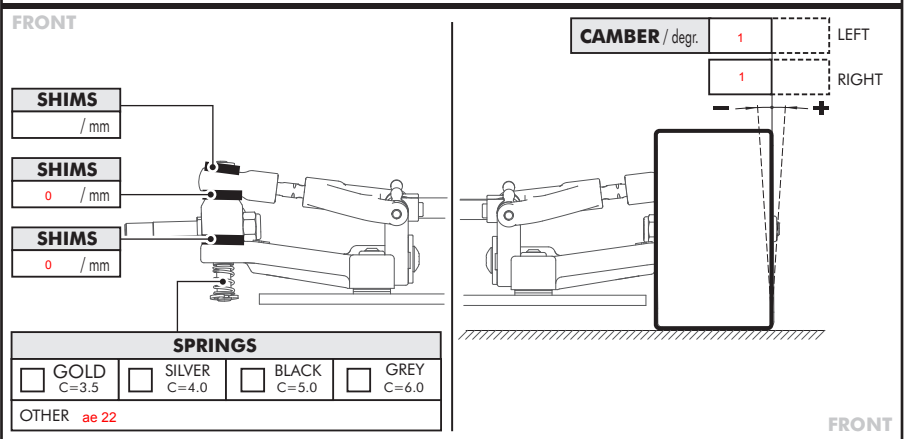
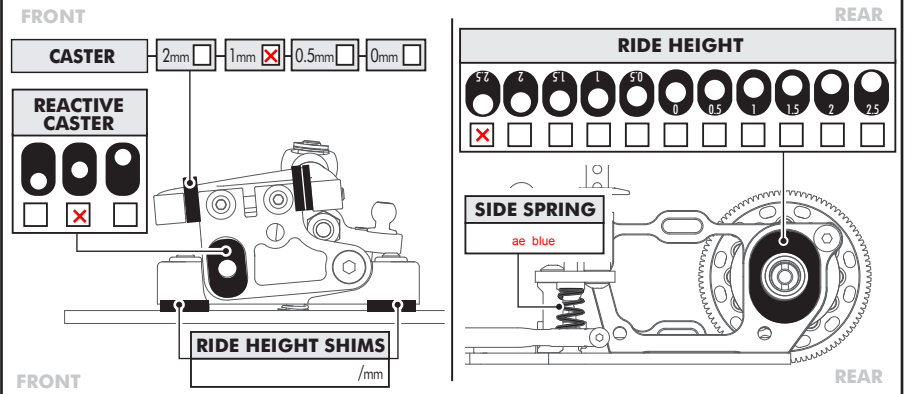
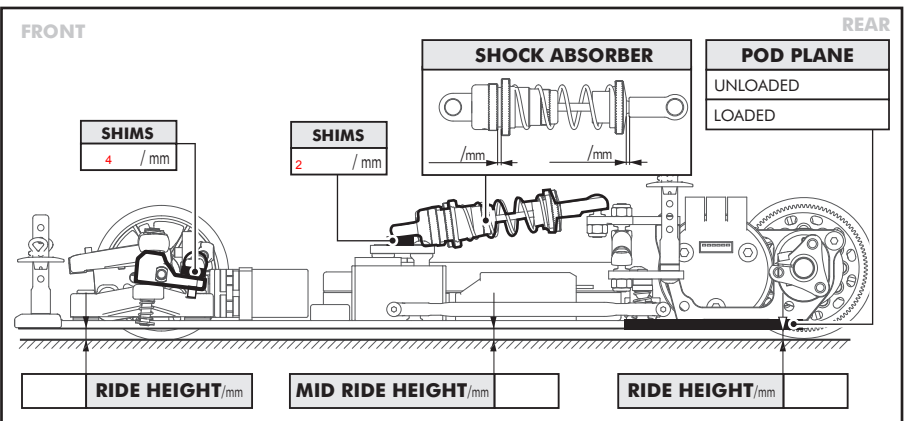

COMMENTS

3mm shim for longer camber link

one hole in stock piston

boost: 18deg
rpm: 4000
acc: 350
turbo: 0

26x12m track