

SET-UP SHEET

XRAY X12

RACE	Practise blinky 10.5T	
TRACK	SYK	

NAME	Peakki	
CITY / COUNTRY	Seinajoki	Finland
CONTACT	peakki[at]nic.fi	

DATE	30/12/2012	
-------------	------------	--

TEMPERATURE / <small>F or °C</small>	AIR	TRACK
---	-----	-------

QUALIFYING POSITION	BEST LAPTIME / sec	FINAL POSITION	RACE LENGTH / minutes
	10,1		

TRACK CONDITION	<input checked="" type="checkbox"/> CARPET	<input type="checkbox"/> ASPHALT
	<input type="checkbox"/> TECHNICAL	<input checked="" type="checkbox"/> MIXED
		<input type="checkbox"/> FAST

TRACTION	<input type="checkbox"/> LOW	<input checked="" type="checkbox"/> MEDIUM	<input type="checkbox"/> HIGH
-----------------	------------------------------	--	-------------------------------

CENTER SHOCK ABSORBER		
SPRING	black	OIL / cSt 600
		REBOUND%

SIDE LINKAGES		
	OIL / cSt ur 50k	

FRONT		TIRES	REAR	
MG magenta			mg pink	
39		DIAMETER/mm	41	
Robitronic		ADDITIVE	Robitronic	
10		ADDITIVE timing	20	

FRONT LEFT	FRONT RIGHT	ADDITIVE TREATED AREA	REAR LEFT	REAR RIGHT

TRANSMISSION	
DIFF SETTING	
<input type="checkbox"/> LOOSE	<input checked="" type="checkbox"/> MEDIUM
<input type="checkbox"/>	<input type="checkbox"/> TIGHT

PINION / T	39	SPUR GEAR/T	75
FINAL DRIVE RATIO	1.9230769230769	ROLLOUT	66.9448

MOTOR	
BRAND	Orion Vortex Racing 2008
TURN	10.5T
ROTOR	purple torque type
TIMING	4mm

ESC	Orion R10 1S		
ESC SETTING	PROGRAM	0timing	PUNCH 9
	INITIAL BRAKE	auto	AUTO BRAKE 0
BATTERIES	Reedy 6500		
BODY	BA 05		

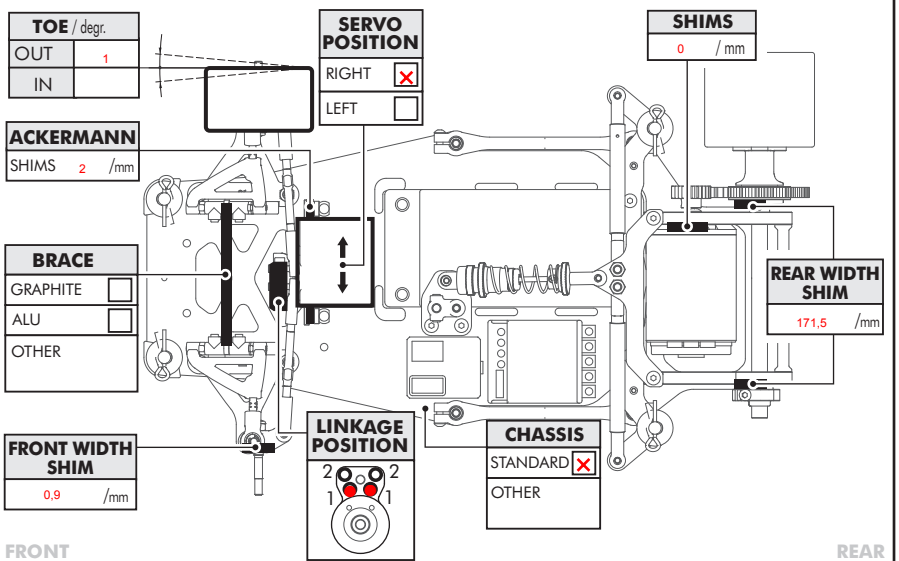
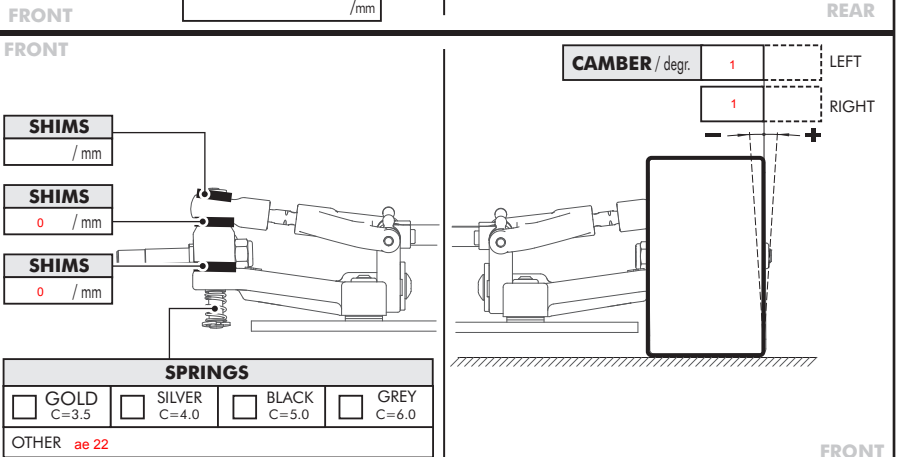
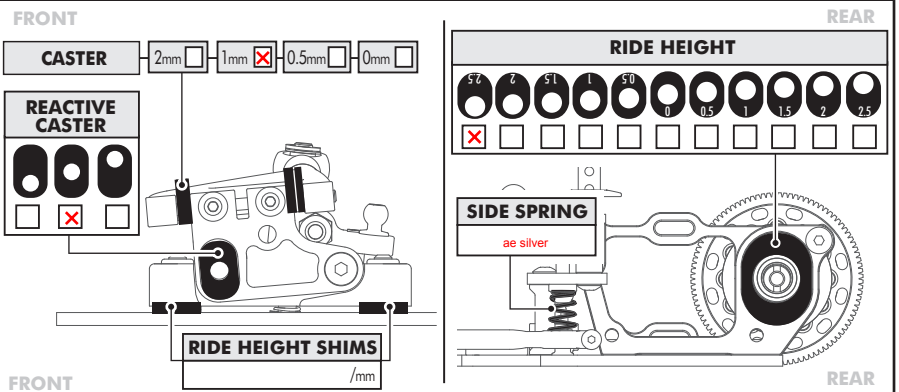
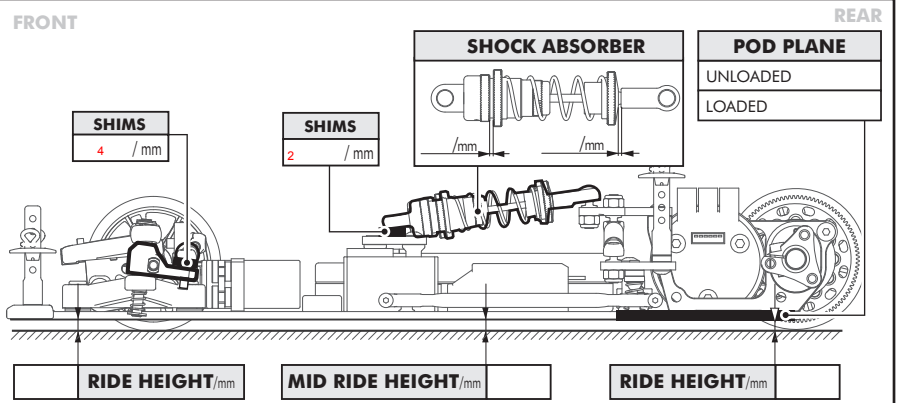

COMMENTS

3mm shim for longer camber link

+38% exp-th

One side tube, different mounting pos than std, similar to XII link

26x12m track