

# SET-UP SHEET

# XRAY X12

|              |                        |  |
|--------------|------------------------|--|
| <b>RACE</b>  | Nirk practise I - Copy |  |
| <b>TRACK</b> | Nokian renkaat         |  |

|                       |         |         |
|-----------------------|---------|---------|
| <b>NAME</b>           | Peakki  |         |
| <b>CITY / COUNTRY</b> | Tampere | Finland |
| <b>CONTACT</b>        | peakki@ |         |

|             |            |  |
|-------------|------------|--|
| <b>DATE</b> | 06/01/2012 |  |
|-------------|------------|--|

|   |     |       |
|---|-----|-------|
| <b>TEMPERATURE</b> / <small>F or °C</small> | AIR | TRACK |
|---|-----|-------|

|                            |                           |                       |                              |
|----------------------------|---------------------------|-----------------------|------------------------------|
| <b>QUALIFYING POSITION</b> | <b>BEST LAPTIME</b> / sec | <b>FINAL POSITION</b> | <b>RACE LENGTH</b> / minutes |
|                            | 11,04                     |                       |                              |

|                        |  |   |
|------------------------|--|---|
| <b>TRACK CONDITION</b> | <input checked="" type="checkbox"/> CARPET | <input type="checkbox"/> ASPHALT          |
|                        | <input type="checkbox"/> TECHNICAL         | <input checked="" type="checkbox"/> MIXED |
|                        |  | <input type="checkbox"/> FAST             |

|                 |                              |  |                               |
|-----------------|------------------------------|--|-------------------------------|
| <b>TRACTION</b> | <input type="checkbox"/> LOW | <input checked="" type="checkbox"/> MEDIUM | <input type="checkbox"/> HIGH |
|-----------------|------------------------------|--|-------------------------------|

|                              |      |                      |
|------------------------------|------|----------------------|
| <b>CENTER SHOCK ABSORBER</b> |      |                      |
| <b>SPRING</b>                | gold | <b>OIL / cSt</b> 700 |
|                              |      | <b>REBOUND%</b>      |

|                      |        |
|----------------------|--------|
| <b>SIDE LINKAGES</b> |        |
| <b>OIL / cSt</b>     | ur 20k |

| FRONT   | TIRES           | REAR        |
|---------|-----------------|-------------|
| jaco dp |                 | grp Magenta |
| 41,5    | DIAMETER/mm     | 43,5        |
| cs hq   | ADDITIVE        | cs hq       |
| 10      | ADDITIVE timing | 20          |

|                   |                    |                              |                  |                   |
|-------------------|--------------------|------------------------------|------------------|-------------------|
| <b>FRONT LEFT</b> | <b>FRONT RIGHT</b> | <b>ADDITIVE TREATED AREA</b> | <b>REAR LEFT</b> | <b>REAR RIGHT</b> |
|                   |                    |                              |                  |                   |

|   |                                 |
|---|---------------------------------|
| <b>TRANSMISSION</b>                       |                                 |
| <b>DIFF SETTING</b>                       |                                 |
| <input type="checkbox"/> LOOSE            | <input type="checkbox"/> MEDIUM |
| <input checked="" type="checkbox"/> TIGHT | <input type="checkbox"/>        |

|                          |      |                    |                 |
|--------------------------|------|--------------------|-----------------|
| <b>PINION / T</b>        | 20   | <b>SPUR GEAR/T</b> | 95              |
| <b>FINAL DRIVE RATIO</b> | 4.75 | <b>ROLLOUT</b>     | 28.425263157895 |

|               |                  |
|---------------|------------------|
| <b>MOTOR</b>  |                  |
| <b>BRAND</b>  | Orion Vortex VST |
| <b>TURN</b>   | 4.0T             |
| <b>ROTOR</b>  | std              |
| <b>TIMING</b> | 0mm              |

|                    |                      |                          |                     |
|--------------------|----------------------|--------------------------|---------------------|
| <b>ESC</b>         | SP GT 2.1 EX         |                          |                     |
| <b>ESC SETTING</b> | <b>PROGRAM</b>       | <input type="checkbox"/> | <b>PUNCH</b> 3      |
|                    | <b>INITIAL BRAKE</b> | 0                        | <b>AUTO BRAKE</b> 0 |

|                  |          |
|------------------|----------|
| <b>BATTERIES</b> | CRC 6300 |
| <b>BODY</b>      | PF AMR12 |

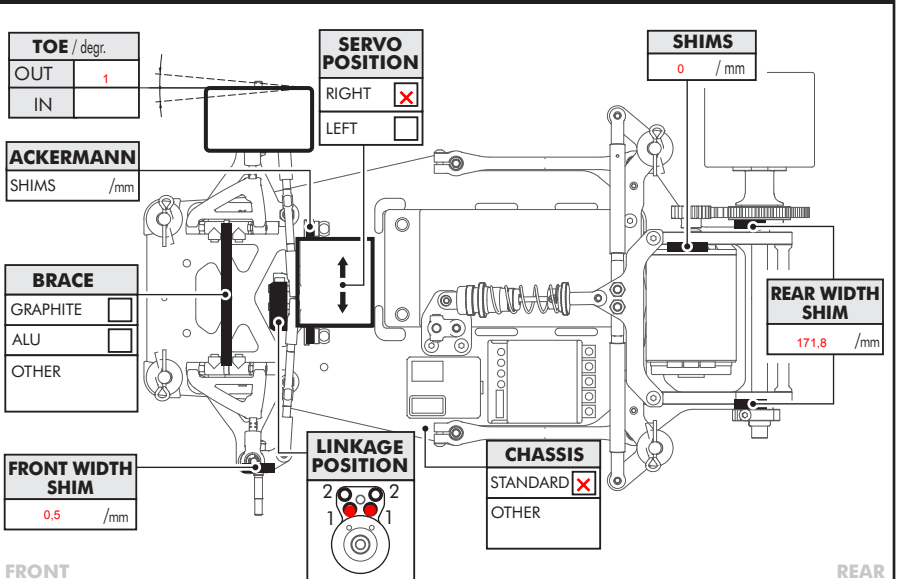
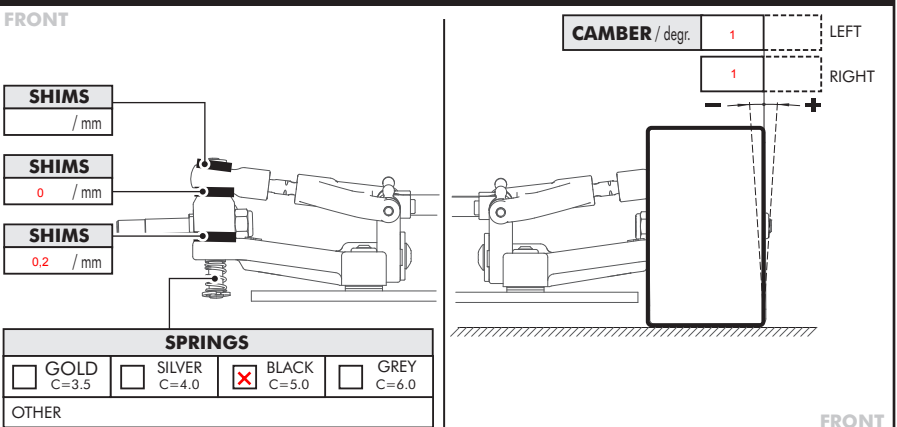
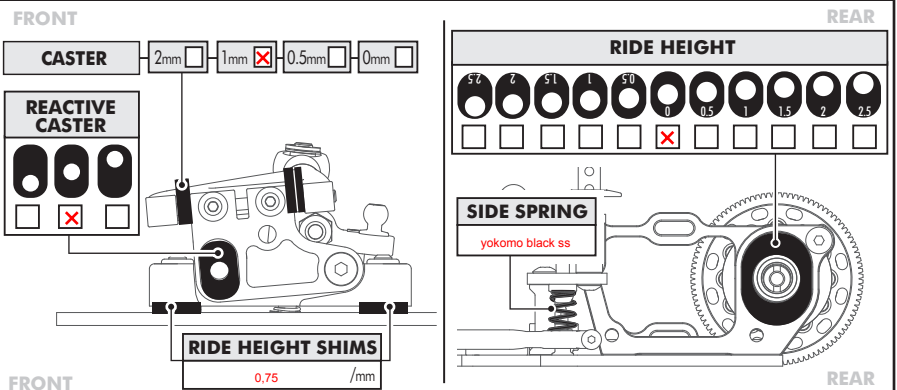
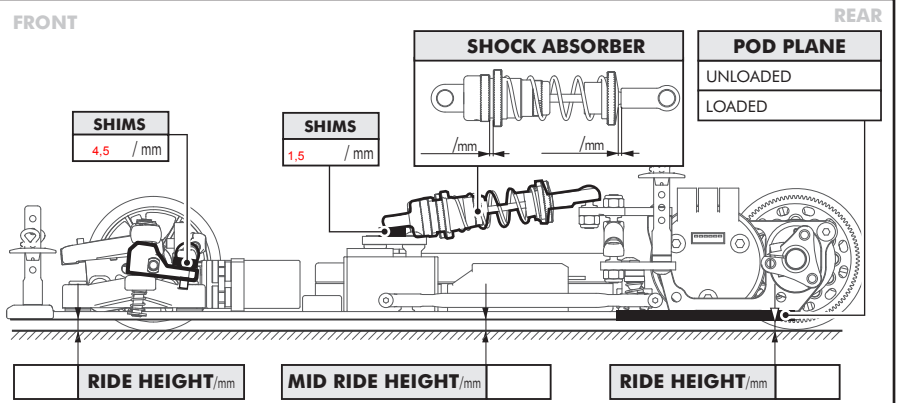

**COMMENTS**

24x14m track

43l 8.067 11.31 avg

long upper link: 1.5mm shim between caster block and arm

1m in servo, 1mm behind steering links - less ackerman

one hole in shock piston

esc:  
boost: 0  
ddrs punch: 3  
turbo: 14