

SET-UP SHEET

XRAY X12

RACE	MACH Indoor - Race 3
TRACK	MACH Indoor - Haarlem

NAME	jaroracing	
CITY / COUNTRY	Roosendaal	Netherlands
CONTACT	info@jaro-racing.nl	

DATE	18/12/2011	
-------------	------------	--

TEMPERATURE / °F or °C	AIR 20	TRACK 15
-------------------------------	--------	----------

QUALIFYING POSITION	BEST LAPTIME / sec	FINAL POSITION	RACE LENGTH / minutes
7		8	8 min

TRACK CONDITION	<input checked="" type="checkbox"/> CARPET	<input type="checkbox"/> ASPHALT
	<input type="checkbox"/> TECHNICAL	<input type="checkbox"/> MIXED
	<input type="checkbox"/> FAST	<input checked="" type="checkbox"/> FAST

TRACTION	<input type="checkbox"/> LOW	<input type="checkbox"/> MEDIUM	<input checked="" type="checkbox"/> HIGH
-----------------	------------------------------	---------------------------------	--

CENTER SHOCK ABSORBER		
SPRING	Silver	OIL / cSt 70
		REBOUND% 80

SIDE LINKAGES	
OIL / cSt	3000 Kit

FRONT	TIRES	REAR
Mob. Magenta		Mob. Magenta
-	DIAMETER/mm	-
Mobers	ADDITIVE	Mobers
15 min	ADDITIVE timing	30 min

FRONT LEFT	FRONT RIGHT	ADDITIVE TREATED AREA	REAR LEFT	REAR RIGHT

TRANSMISSION	
DIFF SETTING	
<input type="checkbox"/> LOOSE	<input type="checkbox"/> MEDIUM
<input checked="" type="checkbox"/> TIGHT	<input type="checkbox"/>

PINION / T	30	SPUR GEAR/T	80
FINAL DRIVE RATIO	2.6666666666667	ROLLOUT	0

MOTOR	
BRAND	SpeedPassion
TURN	13,5T
ROTOR	Std
TIMING	10 deg

ESC	LRP SXX SS V2	
ESC SETTING	PROGRAM	7
	PUNCH	10
	INITIAL BRAKE	-
	AUTO BRAKE	-

BATTERIES	Orion Carbon PRO 6400 90C
BODY	Protoform LMR

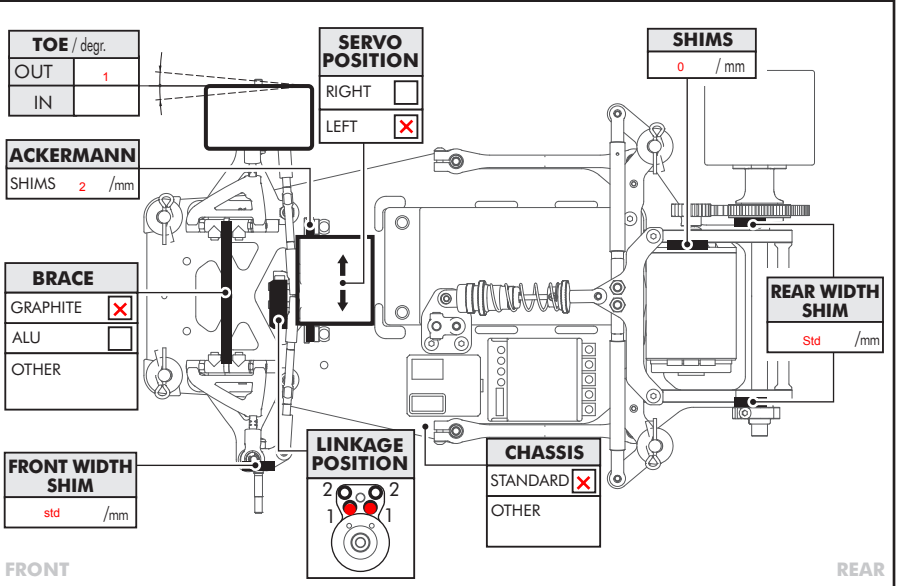
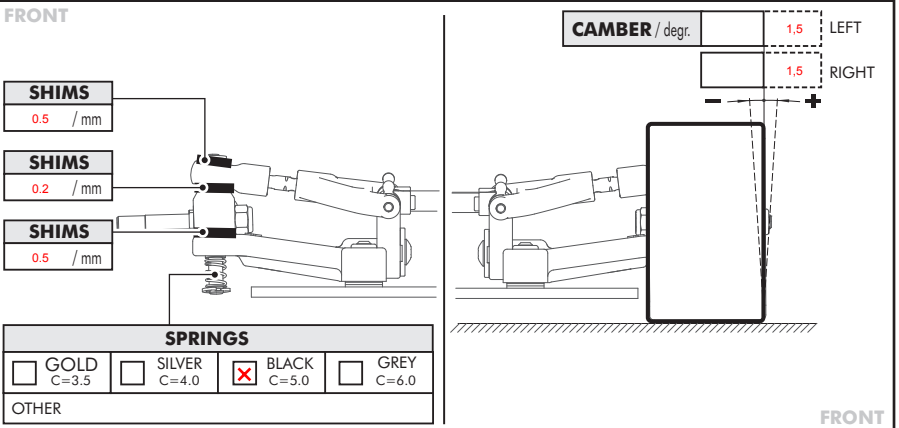
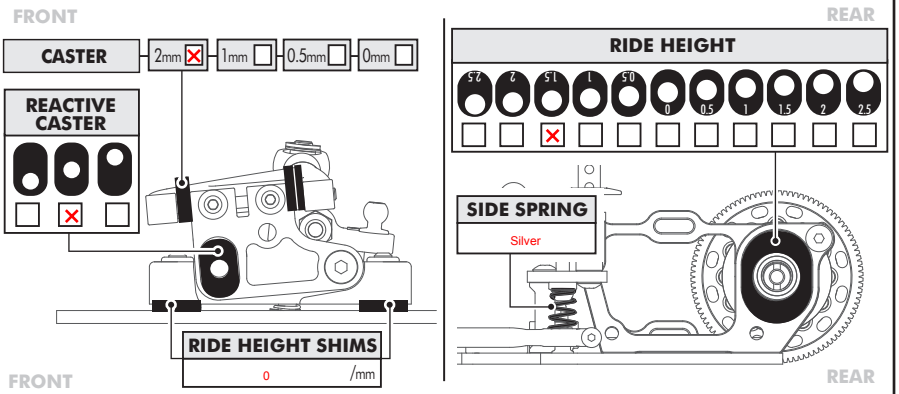
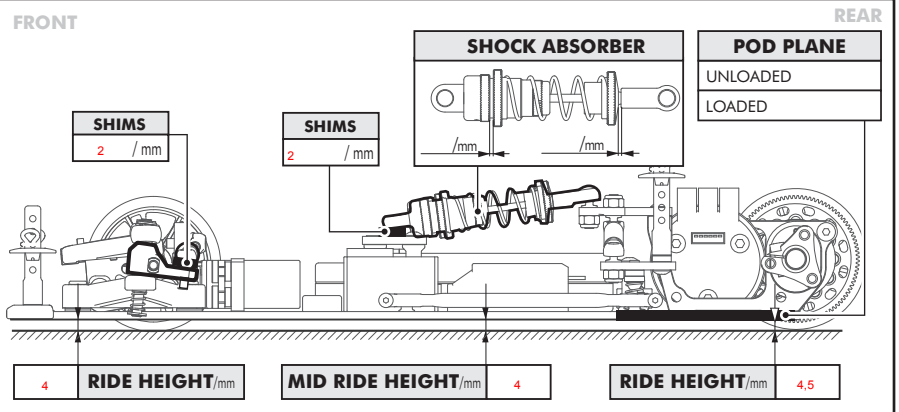

COMMENTS

Car was good, without turning tweak screws.

Motor has not enough power.