

SET-UP SHEET

RACE	Basic CARPET Set-Up		
TRACK			

NAME			
CITY / COUNTRY			
CONTACT			

DATE			
TEMPERATURE / °F or °C	AIR	TRACK	

QUALIFYING POSITION	BEST LAPTIME / sec	FINAL POSITION	RACE LENGTH / minutes

TRACK CONDITION	<input checked="" type="checkbox"/> CARPET	<input type="checkbox"/> ASPHALT
	<input type="checkbox"/> TECHNICAL	<input checked="" type="checkbox"/> MIXED
	<input checked="" type="checkbox"/> MEDIUM	<input type="checkbox"/> HIGH

CENTER SHOCK ABSORBER			
SPRING	std.	OIL / cSt	700
		REBOUND %	50%

SIDE LINKAGES	
OIL / cSt	3000

FRONT		REAR	
TIRES			
43	DIAMETER/mm	45	
ADDITIVE			
ADDITIVE timing			
FRONT LEFT	FRONT RIGHT	REAR LEFT	REAR RIGHT
ADDITIVE TREATED AREA			

TRANSMISSION	
DIFF SETTING	
<input type="checkbox"/> LOOSE	<input checked="" type="checkbox"/> MEDIUM
<input type="checkbox"/> TIGHT	

PINION / T		SPUR GEAR/T	
FINAL DRIVE RATIO		ROLLOUT	

MOTOR	
BRAND	
TURN	
ROTOR	
TIMING	

ESC			
ESC SETTING	PROGRAM	<input type="checkbox"/> PUNCH	<input type="checkbox"/>
	INITIAL BRAKE	<input type="checkbox"/> AUTO BRAKE	<input type="checkbox"/>
BATTERIES			
BODY			

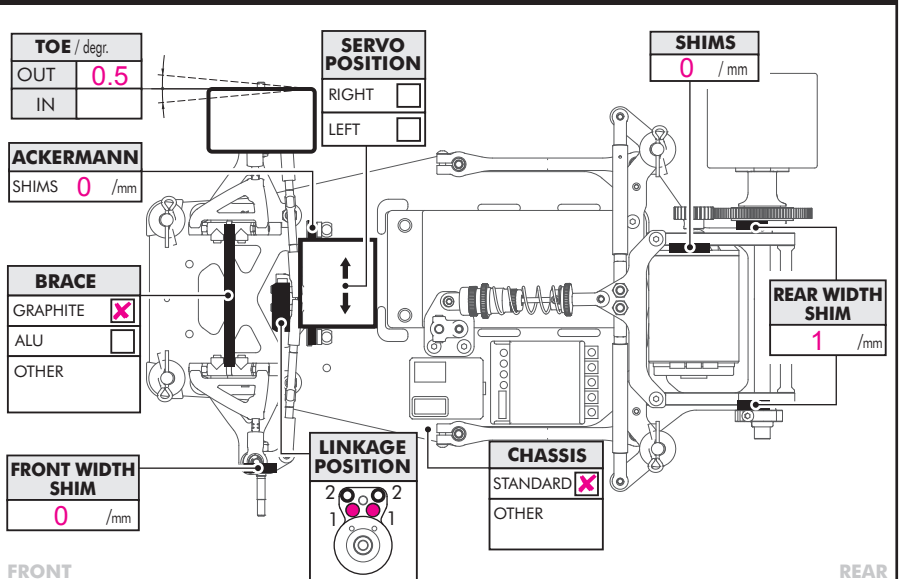
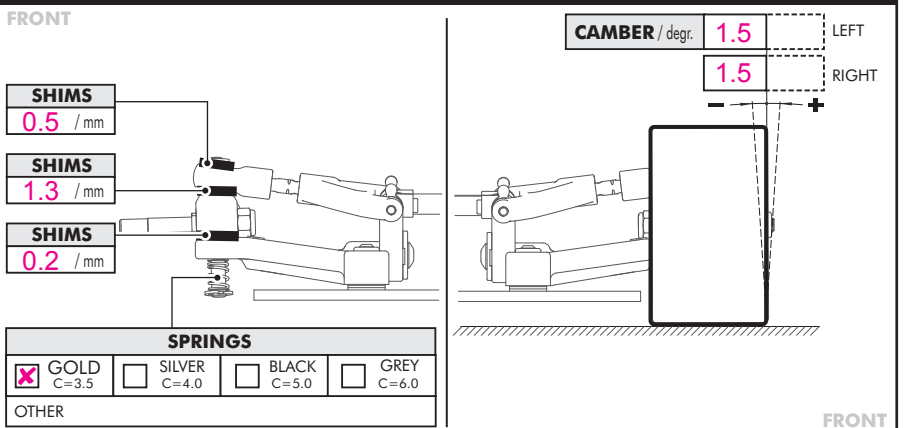
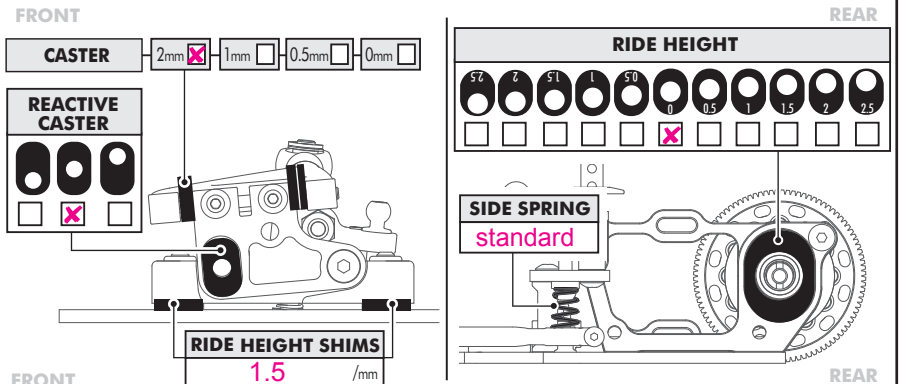
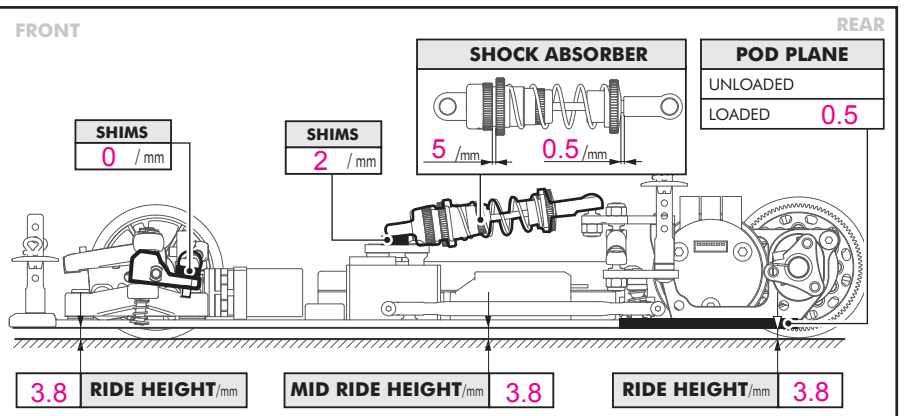

COMMENTS

Ride height is directly affected by tire diameter. This basic set-up is intended for medium tire sizes. When smaller or larger diameter tires are used, the ride height must be changed as appropriate.