

SET-UP SHEET

XRAY X12

RACE	2013 NZ National Champs	
TRACK	Ruapuna	

NAME	Andrew Webber	
CITY / COUNTRY	Hamilton	New Zealand
CONTACT		

DATE	18/02/2013	
-------------	------------	--

TEMPERATURE / <small>F or °C</small>	AIR	20	TRACK	30
---	-----	----	-------	----

QUALIFYING POSITION	BEST LAP TIME / sec	FINAL POSITION	RACE LENGTH / minutes
2	20.5	2	8

TRACK CONDITION	<input type="checkbox"/> CARPET	<input checked="" type="checkbox"/> ASPHALT
	<input type="checkbox"/> TECHNICAL	<input type="checkbox"/> MIXED
		<input checked="" type="checkbox"/> FAST

TRACTION		
<input type="checkbox"/> LOW	<input checked="" type="checkbox"/> MEDIUM	<input type="checkbox"/> HIGH

CENTER SHOCK ABSORBER		
SPRING	2.1	OIL / cSt
		650
		REBOUND%
		0

SIDE LINKAGES	
OIL / cSt	30000

FRONT		TIRES	REAR	
Xceed Hard			Xceed Soft	
		DIAMETER/mm		
		ADDITIVE		
		ADDITIVE timing		
FRONT LEFT	FRONT RIGHT	ADDITIVE TREATED AREA	REAR LEFT	REAR RIGHT

TRANSMISSION		
DIFF SETTING		
<input type="checkbox"/> LOOSE	<input checked="" type="checkbox"/> MEDIUM	<input type="checkbox"/> TIGHT

PINION / T	35	SPUR GEAR/T	78
FINAL DRIVE RATIO	2.2285714285714	ROLLOUT	NaN

MOTOR	
BRAND	SP
TURN	5
ROTOR	Kit
TIMING	Kit

ESC		
ESC SETTING	PROGRAM	PUNCH
	<input type="checkbox"/>	1
	INITIAL BRAKE	AUTO BRAKE
	<input type="checkbox"/>	8

BATTERIES	TP 6800mah
BODY	AMR12

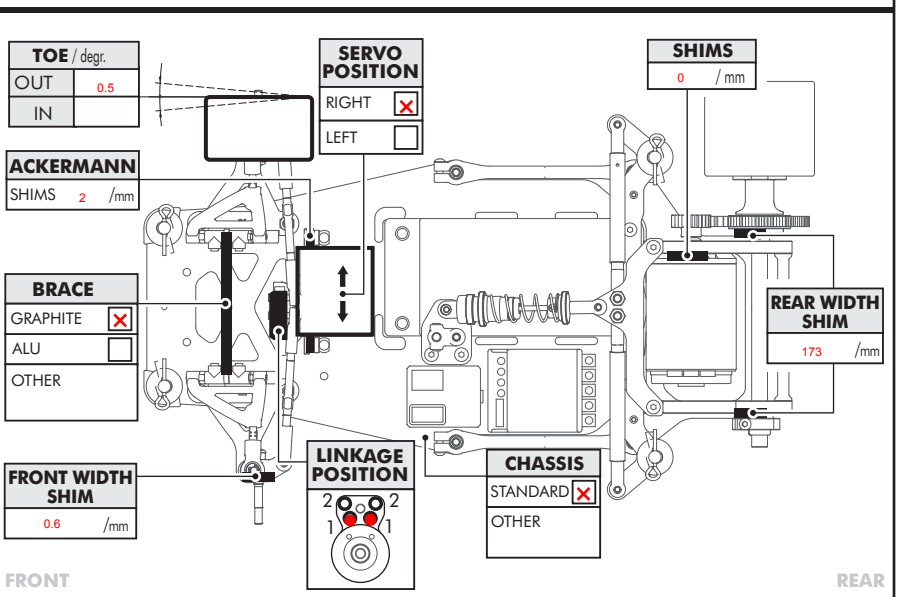
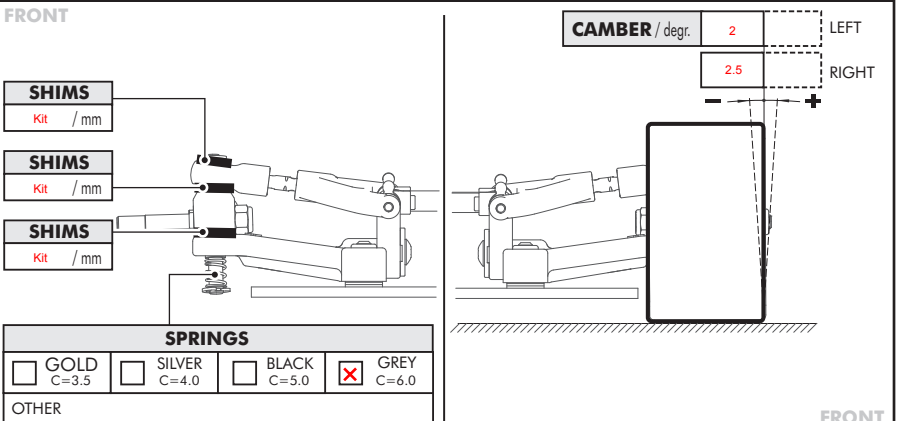
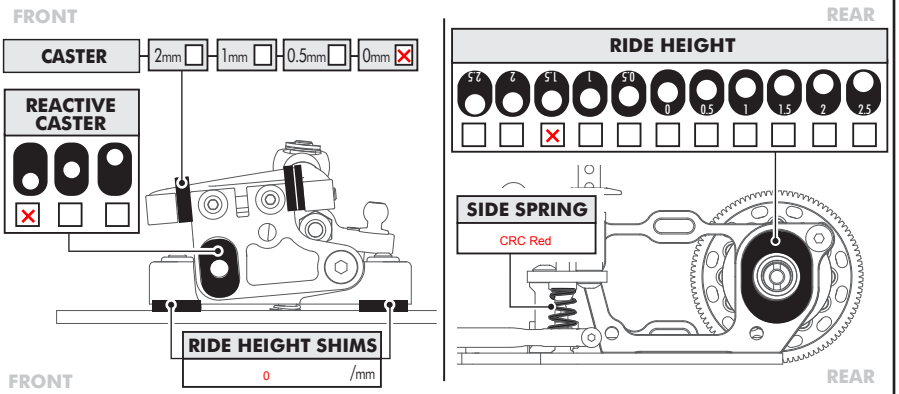
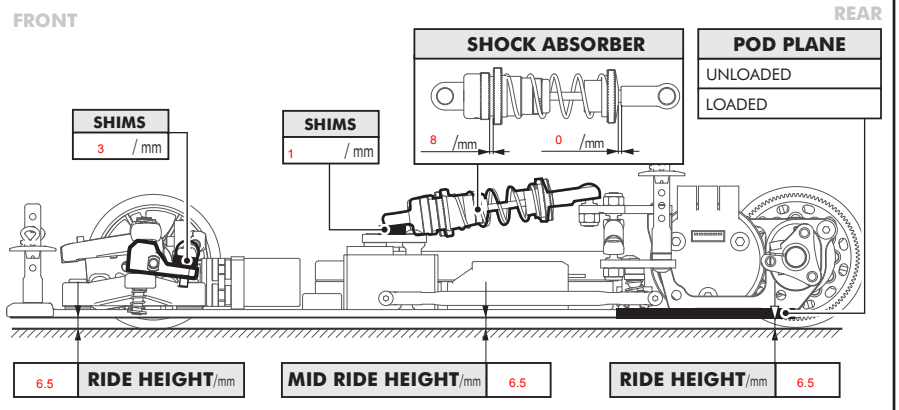

COMMENTS

Extremely Bumpy, high speed track.