

SET-UP SHEET

RACE	WC	
TRACK	RCS	

NAME	Teemu Leino	
CITY / COUNTRY	BANGKOK	Thailand
CONTACT		

DATE	26/08/2009	
-------------	------------	--

TEMPERATURE / For °C	AIR	TRACK
-----------------------------	-----	-------

QUALIFYING POSITION	BEST LAPTIME / sec	FINAL POSITION	RACE LENGTH / minutes

TRACK CONDITION	<input type="checkbox"/> CARPET	<input checked="" type="checkbox"/> ASPHALT
	<input type="checkbox"/> TECHNICAL	<input checked="" type="checkbox"/> MIXED
		<input type="checkbox"/> FAST

TRACTION	<input type="checkbox"/> LOW	<input checked="" type="checkbox"/> MEDIUM	<input type="checkbox"/> HIGH
-----------------	------------------------------	--	-------------------------------

SHOCK ABSORBER	
SPRING	STD
OIL / cSt	300
REBOUND %	20%

FRONT		REAR	
PARMA PURPLE	TIRES	PARMA PINK	
42	DIAMETER/mm	46.5	
	ADDITIVE		
sun cream and fx2	ADDITIVE timing	sun cream and fx2	
FRONT LEFT	FRONT RIGHT	REAR LEFT	REAR RIGHT
ADDITIVE TREATED AREA			

TRANSMISSION	
DIFF SETTING	
<input type="checkbox"/> LOOSE	<input checked="" type="checkbox"/> MEDIUM
<input type="checkbox"/> TIGHT	

PINION / T	24	SPUR GEAR /T	96
FINAL DRIVE RATIO	6.8	ROLLOUT	19.394

BRUSHED MOTOR	
BRAND	
ARMATURE	
	<input checked="" type="checkbox"/> SPRING
	<input checked="" type="checkbox"/> BRUSH COMP.

BRUSHLESS MOTOR	
BRAND	ORION
TURN	4.5
ROTOR	12MM
TIMING	

ESC	LRP	
ESC SETTING	PROGRAM <input type="text" value="2"/>	PUNCH <input type="text" value="4"/>
	INITIAL BRAKE <input type="text" value="0"/>	AUTO BRAKE <input type="text" value="0"/>

BATTERIES	ORION	
BODY	PF SPEED12	

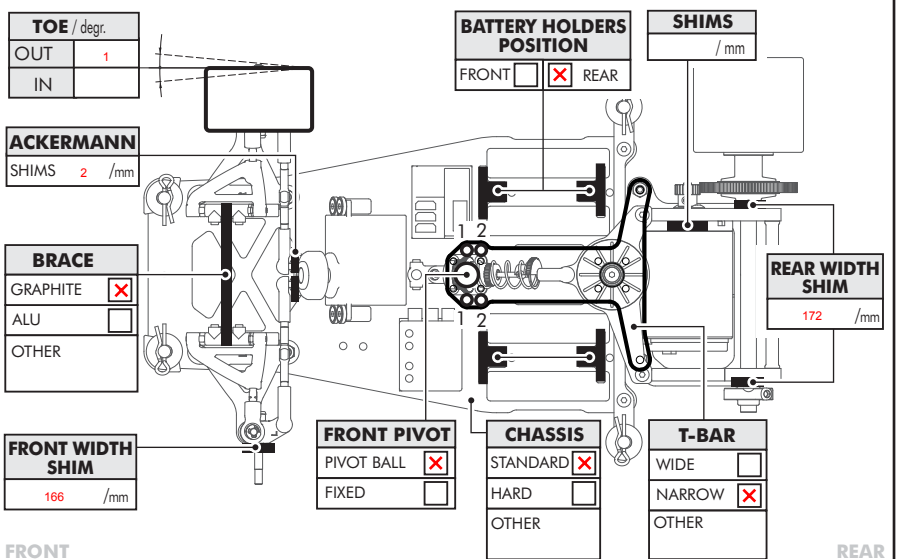
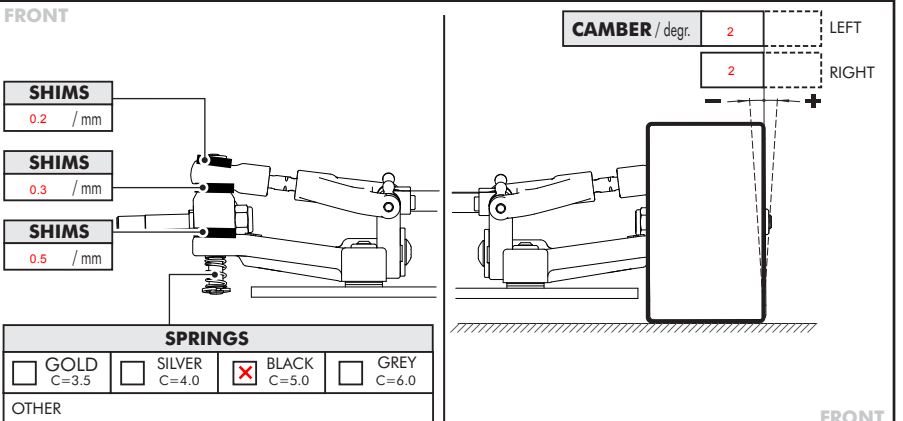
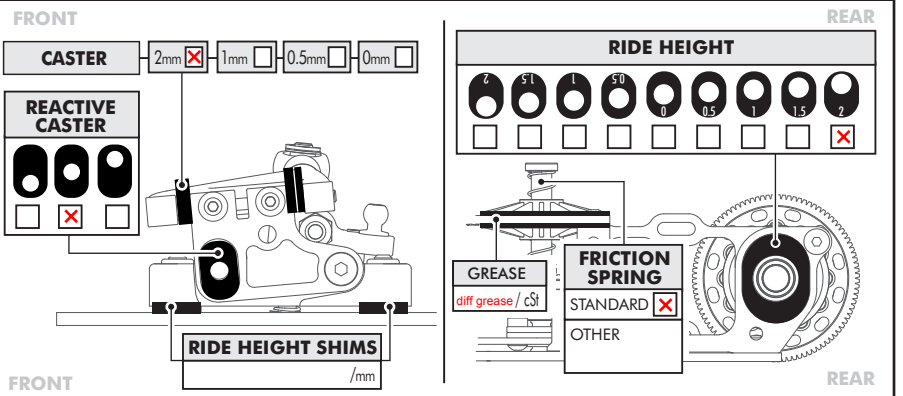
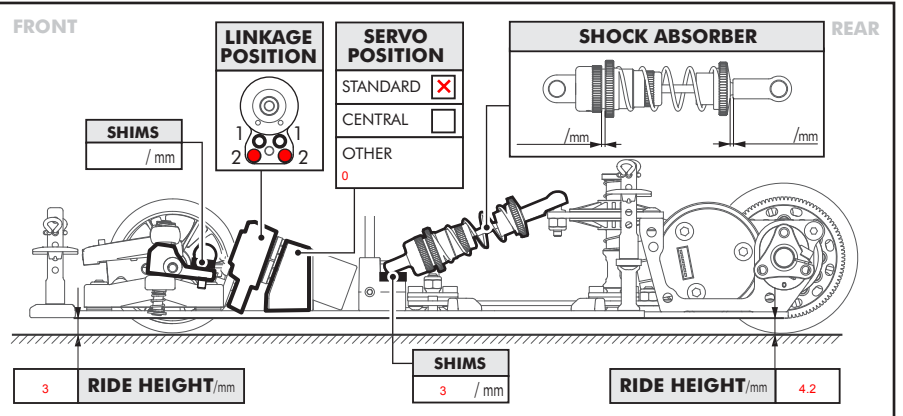

COMMENTS