

SET-UP SHEET

RACE	Club	
TRACK	OCS	

NAME	Paul Paras	
CITY / COUNTRY	Pearl City	USA
CONTACT		

DATE	09/02/2009	
-------------	------------	--

TEMPERATURE / °F or °C	AIR	82	TRACK
-------------------------------	-----	----	-------

QUALIFYING POSITION	BEST LAPTIME / sec	FINAL POSITION	RACE LENGTH / minutes
3rd	8.1	1st	8

TRACK CONDITION	<input type="checkbox"/> CARPET	<input checked="" type="checkbox"/> ASPHALT
	<input checked="" type="checkbox"/> TECHNICAL	<input type="checkbox"/> MIXED <input type="checkbox"/> FAST

TRACTION
<input type="checkbox"/> LOW <input type="checkbox"/> MEDIUM <input checked="" type="checkbox"/> HIGH

SHOCK ABSORBER	
SPRING	stock
OIL / cSt	350cst
REBOUND %	50

FRONT		REAR	
Jaco dbl pink	TIRES	Jaco pink	
43	DIAMETER/mm	44	
paragon	ADDITIVE	paragon	
10min	ADDITIVE timing	10min	
FRONT LEFT	FRONT RIGHT	REAR LEFT	REAR RIGHT
ADDITIVE TREATED AREA			

TRANSMISSION	
DIFF SETTING	
<input type="checkbox"/> LOOSE	<input checked="" type="checkbox"/> MEDIUM <input type="checkbox"/> TIGHT

PINION / T	42	SPUR GEAR /T	80
FINAL DRIVE RATIO	3.238	ROLLOUT	41.699

BRUSHED MOTOR	
BRAND	
ARMATURE	
	<input checked="" type="checkbox"/> SPRING <input type="checkbox"/>
	<input checked="" type="checkbox"/> BRUSH COMP. <input type="checkbox"/>

BRUSHLESS MOTOR	
BRAND	Trinity
TURN	17.5
ROTOR	stock
TIMING	0°

ESC	Tekin RS	
ESC SETTING	PROGRAM	189
	PUNCH	max
	INITIAL BRAKE	50
	AUTO BRAKE	50

BATTERIES	Trinity EP 4600	
BODY	Parma Speed8	

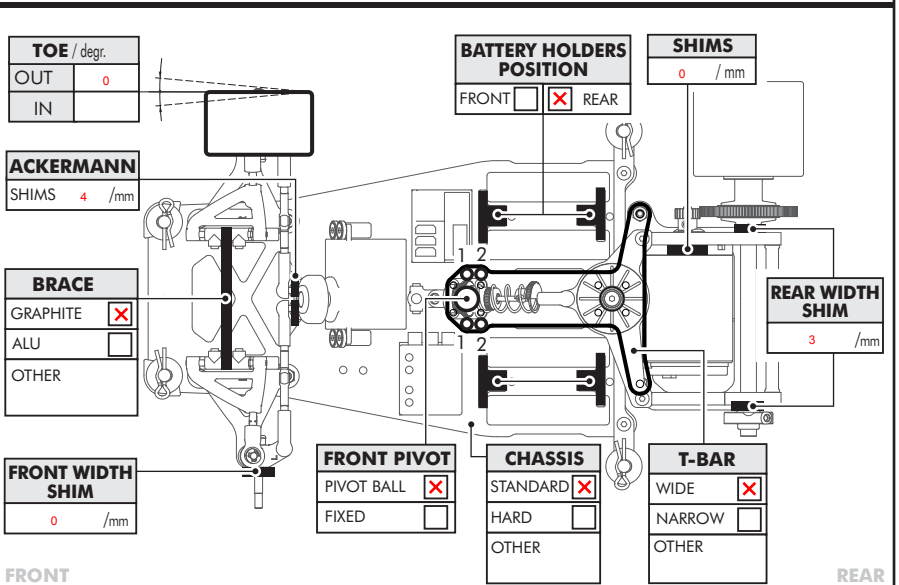
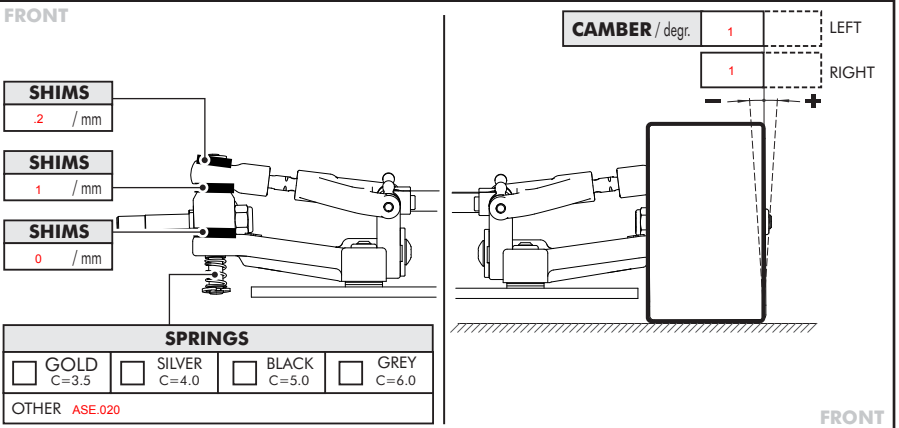
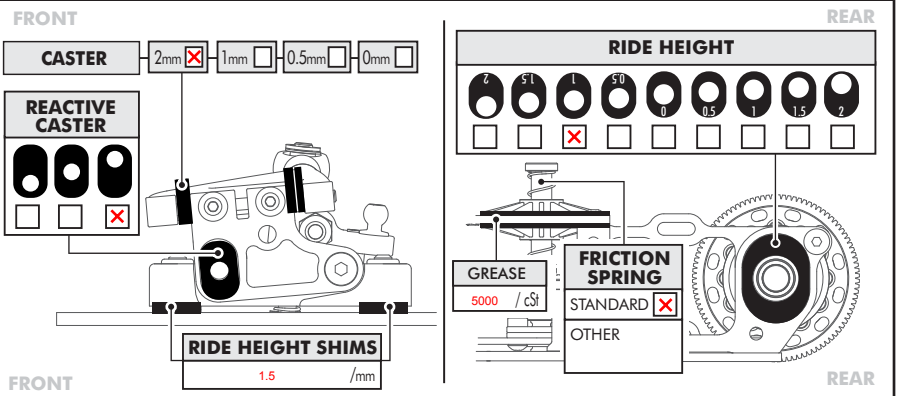
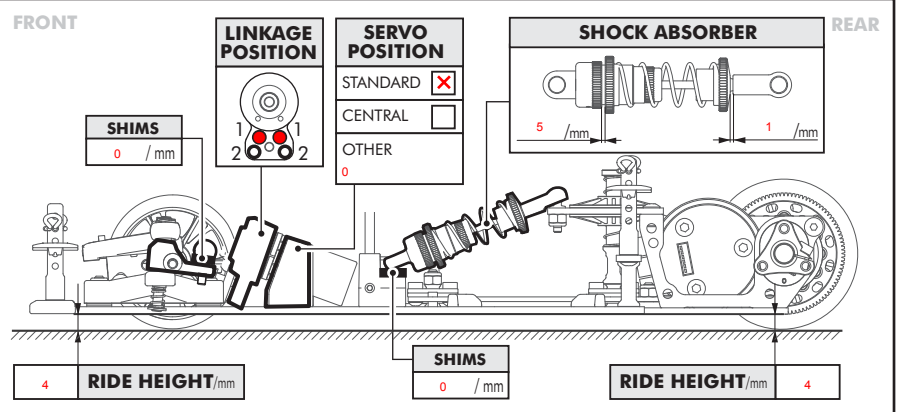

COMMENTS

Car was very good in main. Easy to drive, had a slight push on power, try less rear droop. Not bad for first race w/the car. Ran Tekin RS w/189 software, max boost w/0° timing on motor.