

SET-UP SHEET

XRAY XII

RACE	Training 06.02.2009	
TRACK	Vorwerk	

NAME	Mike Cz.	
CITY / COUNTRY	Vorwerk Celle	Germany
CONTACT		

DATE	08/02/2009		
TEMPERATURE / °F or °C	AIR 21°	TRACK	?

QUALIFYING POSITION	BEST LAPTIME / sec	FINAL POSITION	RACE LENGTH / minutes
	8.60		6

TRACK CONDITION	<input checked="" type="checkbox"/> CARPET	<input type="checkbox"/> ASPHALT
	<input type="checkbox"/> TECHNICAL	<input checked="" type="checkbox"/> MIXED
	<input checked="" type="checkbox"/> MEDIUM	<input type="checkbox"/> FAST
TRACTION	<input type="checkbox"/> LOW	<input type="checkbox"/> HIGH

SHOCK ABSORBER	
SPRING	Standard
OIL / cSt	350
REBOUND %	100%

FRONT	TIRES	REAR	
Purple		Yellow	
43	DIAMETER/mm	45,80	
CS High Grip	ADDITIVE	CS High Grip	
10	ADDITIVE timing	30	
FRONT LEFT	FRONT RIGHT	REAR LEFT	REAR RIGHT
ADDITIVE TREATED AREA			

TRANSMISSION		
DIFF SETTING		
<input type="checkbox"/> LOOSE	<input type="checkbox"/> MEDIUM	<input checked="" type="checkbox"/> TIGHT

PINION / T	32	SPUR GEAR /T	96
FINAL DRIVE RATIO	5.1	ROLLOUT	26.475

BRUSHED MOTOR	
BRAND	
ARMATURE	
	<input checked="" type="checkbox"/> SPRING
	<input checked="" type="checkbox"/> BRUSH COMP.

BRUSHLESS MOTOR	
BRAND	Graupner
TURN	9,5 DMC
ROTOR	Standard
TIMING	Standard

ESC	Nosram	
ESC SETTING	PROGRAM 2	PUNCH 7
	INITIAL BRAKE 0	AUTO BRAKE 1

BATTERIES	Schneider's Speedstuff 4600
BODY	Parma 8HD

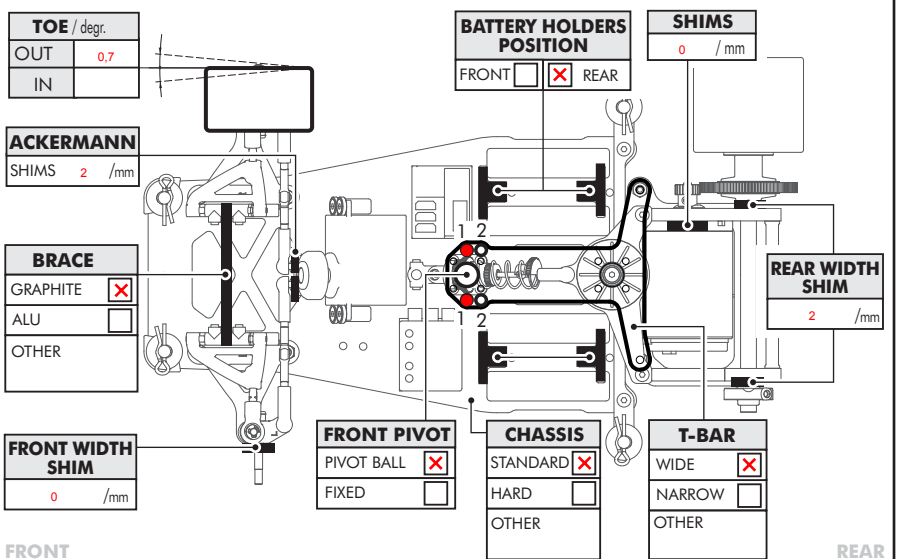
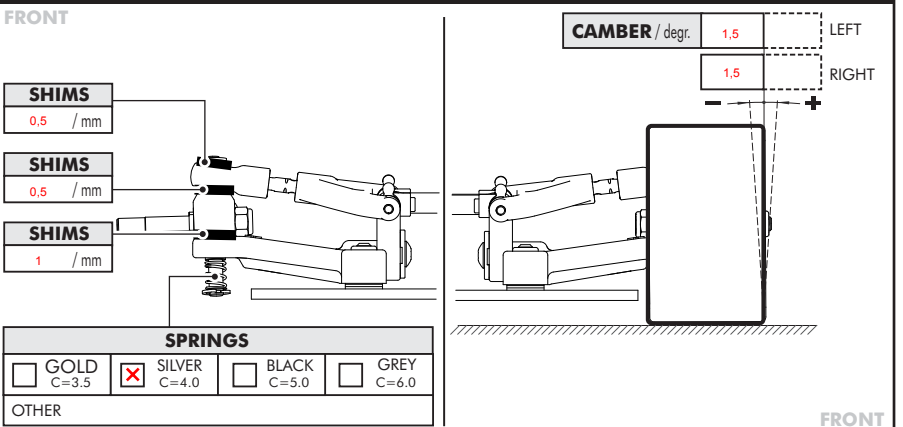
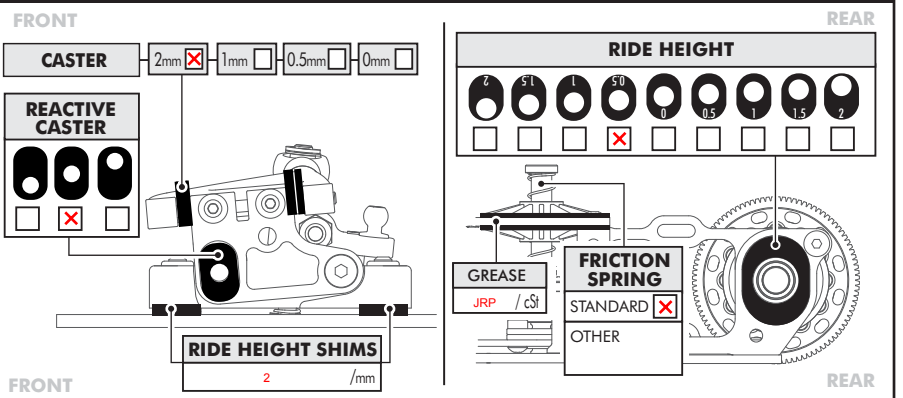
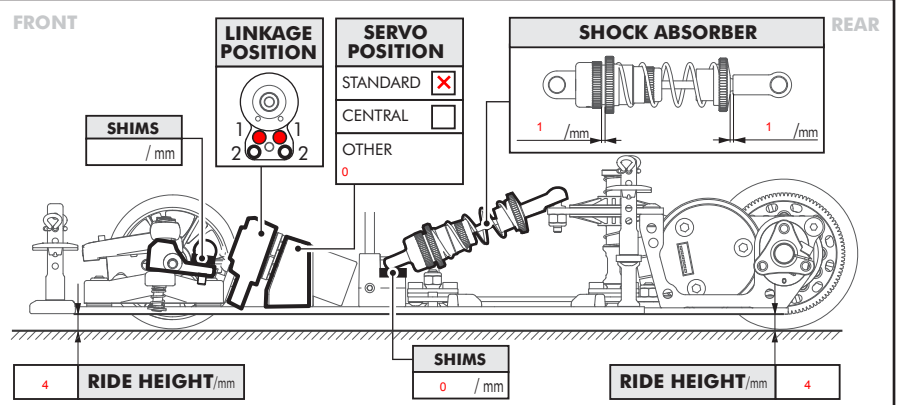

COMMENTS
Graupner servo DS3781, it is adjusted a breath by anchor man. The car let itself steer very goal-exactly around the course. It was first training with that XII, and I was after that 4 accumulator, as with the Asso 12R5 my fastest round 8.66 was faster there already. There I have already however already approx. 20-25 Akkus behind me.