

SET-UP SHEET

RACE	Training	
TRACK	Eskilstuna	

NAME	MackanG	
CITY / COUNTRY	Västerås	Sweden
CONTACT		

DATE	15/02/2009		
TEMPERATURE / °C	AIR	18	TRACK

QUALIFYING POSITION	BEST LAPTIME / sec	FINAL POSITION	RACE LENGTH / minutes
	12.11		

TRACK CONDITION	<input checked="" type="checkbox"/> CARPET	<input type="checkbox"/> ASPHALT
	<input type="checkbox"/> TECHNICAL	<input checked="" type="checkbox"/> MIXED
	<input checked="" type="checkbox"/> MEDIUM	<input type="checkbox"/> FAST
TRACTION	<input type="checkbox"/> LOW	<input type="checkbox"/> HIGH

SHOCK ABSORBER	
SPRING	Stock
OIL / cSt	450
REBOUND %	50%

FRONT	TIRES	REAR
Jaco Dbl pink		Jaco Pink
43	DIAMETER/mm	45
Jack gripper	ADDITIVE	Jack gripper
20min	ADDITIVE timing	45min
FRONT LEFT	FRONT RIGHT	REAR LEFT
	ADDITIVE TREATED AREA	

TRANSMISSION	
DIFF SETTING	
<input type="checkbox"/> LOOSE	<input checked="" type="checkbox"/> MEDIUM
<input type="checkbox"/> TIGHT	
PINION / T	18
SPUR GEAR/T	96
FINAL DRIVE RATIO	9.067
ROLLOUT	14.891

BRUSHED MOTOR	
BRAND	
ARMATURE	
	<input checked="" type="checkbox"/> SPRING
	<input checked="" type="checkbox"/> BRUSH COMP.

BRUSHLESS MOTOR	
BRAND	Novak
TURN	4.5
ROTOR	12.5
TIMING	

ESC	LRP	
ESC SETTING	PROGRAM	PUNCH
	<input type="checkbox"/>	5
	INITIAL BRAKE	AUTO BRAKE
	<input type="checkbox"/>	<input type="checkbox"/>
BATTERIES		
BODY	Speed 12	

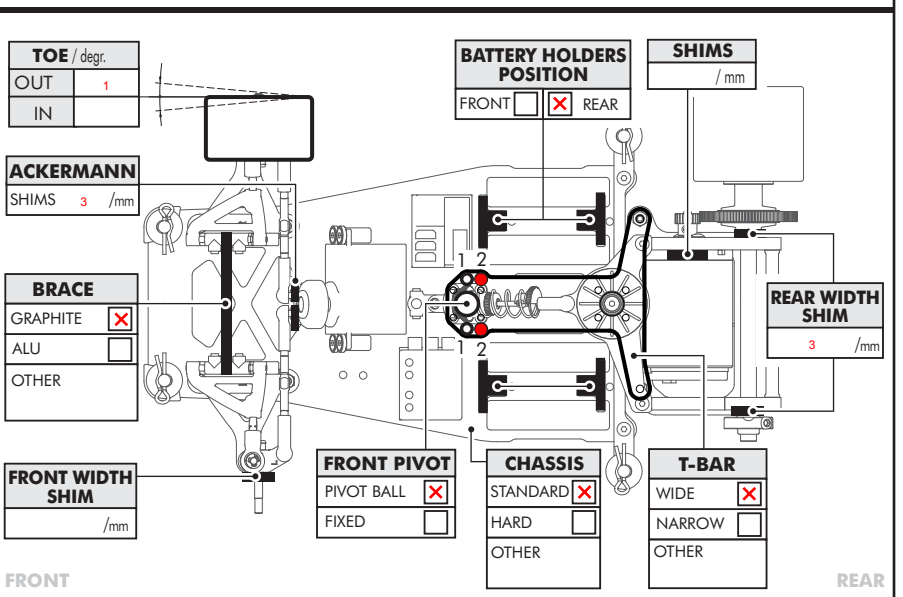
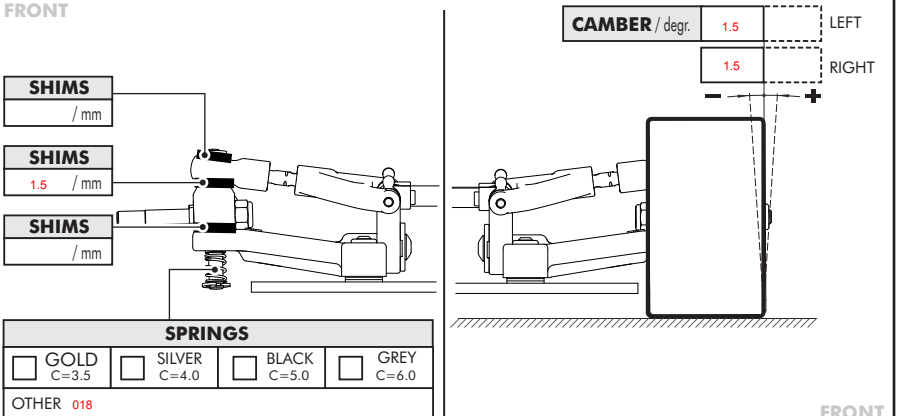
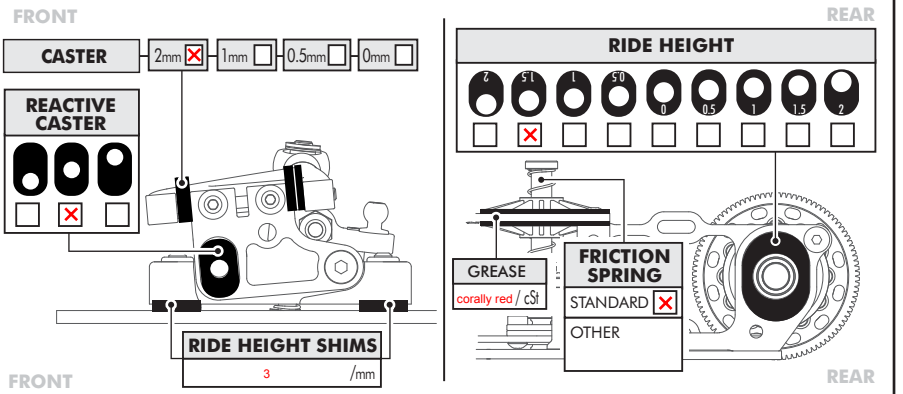
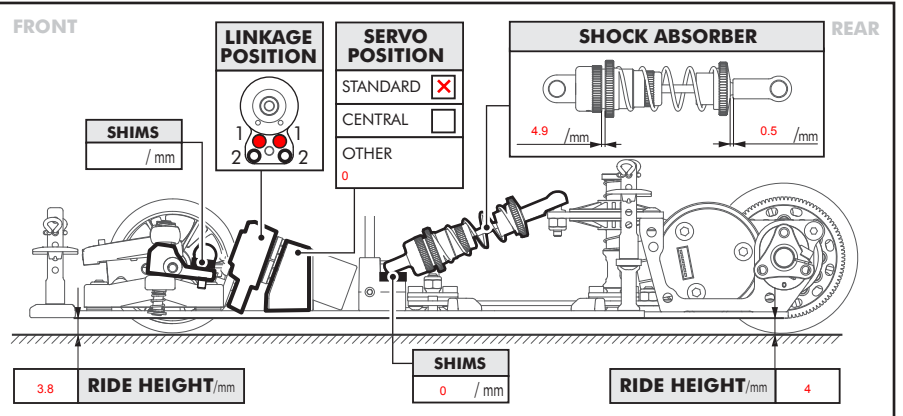

COMMENTS