

SET-UP SHEET

XRAY X11

RACE	SM Lauf Nord
TRACK	Pr. Oldendorf

NAME	Freddy-Südhoff	
CITY / COUNTRY	Rheda	Germany
CONTACT		

DATE	29/11/2009
-------------	------------

TEMPERATURE / °F or °C	AIR	TRACK
-------------------------------	-----	-------

QUALIFYING POSITION	BEST LAPTIME / sec	FINAL POSITION	RACE LENGTH / minutes
1	9,4	1	8

TRACK CONDITION	<input checked="" type="checkbox"/> CARPET	<input type="checkbox"/> ASPHALT
	<input type="checkbox"/> TECHNICAL	<input checked="" type="checkbox"/> MIXED
	<input type="checkbox"/> FAST	

TRACTION	<input type="checkbox"/> LOW	<input type="checkbox"/> MEDIUM	<input checked="" type="checkbox"/> HIGH
-----------------	------------------------------	---------------------------------	--

SHOCK ABSORBER	
SPRING	Kit
OIL / cSt	350
REBOUND %	50%

FRONT		TIRES	REAR
DoublePink			DoublePink
41	DIAMETER/mm	42,5	
Mob	ADDITIVE	Mob	
5	ADDITIVE timing	15	
FRONT LEFT	FRONT RIGHT	ADDITIVE TREATED AREA	REAR LEFT

TRANSMISSION	
DIFF SETTING	
<input type="checkbox"/> LOOSE	<input type="checkbox"/> MEDIUM
<input checked="" type="checkbox"/> TIGHT	<input type="checkbox"/>

PINION / T	24	SPUR GEAR /T	96
FINAL DRIVE RATIO	6.8	ROLLOUT	18.932

BRUSHED MOTOR	
BRAND	
ARMATURE	
<input checked="" type="checkbox"/> SPRING	<input type="checkbox"/>
<input checked="" type="checkbox"/> BRUSH COMP.	<input type="checkbox"/>

BRUSHLESS MOTOR	
BRAND	LRP X12
TURN	5T
ROTOR	12,5
TIMING	

ESC	LRP SXX
ESC SETTING	PROGRAM <input type="checkbox"/> 1 <input checked="" type="checkbox"/> 2 <input type="checkbox"/> 3
	PUNCH <input type="checkbox"/> 4 <input checked="" type="checkbox"/> 5 <input type="checkbox"/> 6
	INITIAL BRAKE <input type="checkbox"/> 0 <input checked="" type="checkbox"/> 1 <input type="checkbox"/> 2
	AUTO BRAKE <input type="checkbox"/> 0 <input checked="" type="checkbox"/> 1 <input type="checkbox"/> 2

BATTERIES	LRP Vtec 4600 HV²
BODY	Black Art

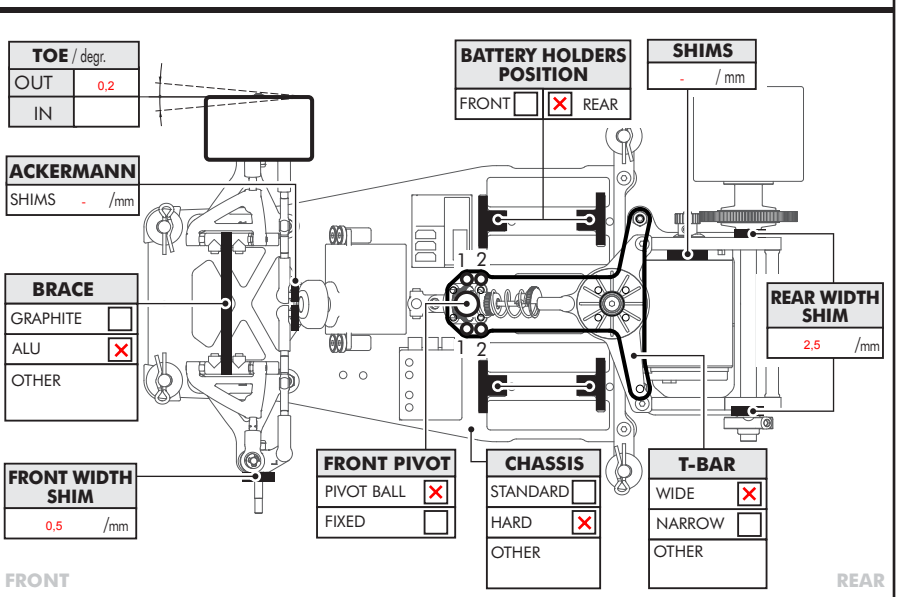
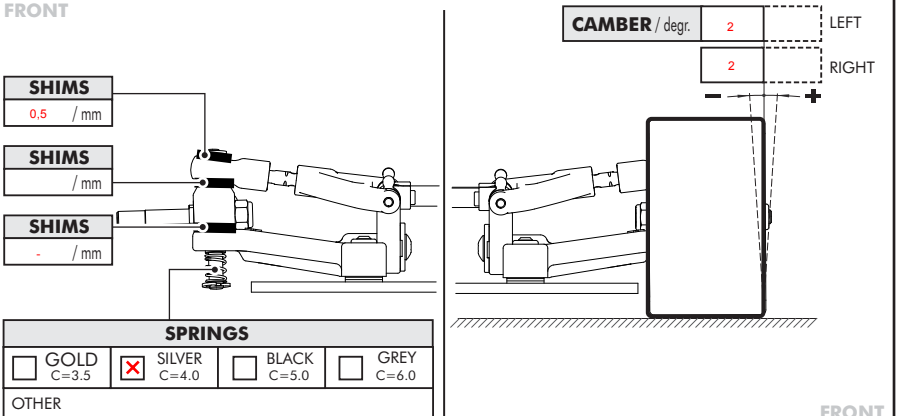
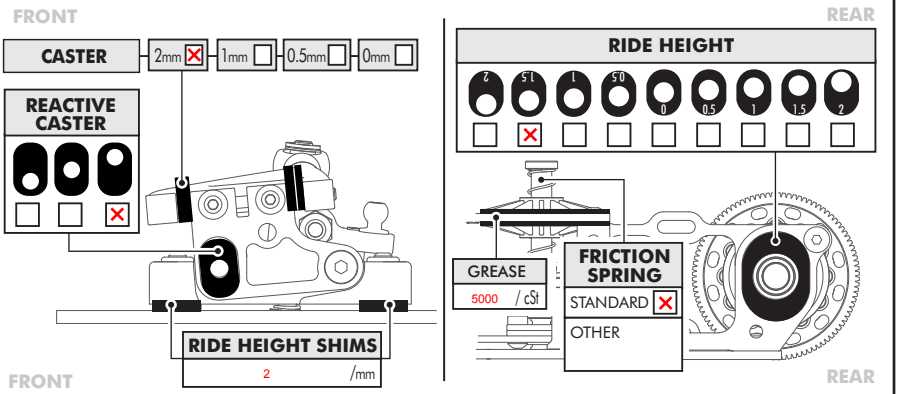
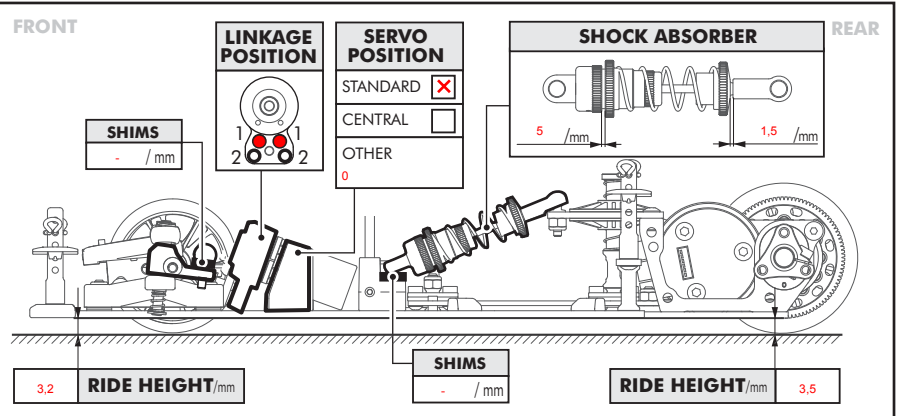

COMMENTS
glue on sidewall of tyre