

SET-UP SHEET

XRAY XII

RACE	ROAR Carpet Nats	
TRACK	The Gate	

NAME	EAMotorsports	
CITY / COUNTRY	Cleveland	USA
CONTACT	EAMotorsports@bellsouth.net	

DATE	03/04/2009	
-------------	------------	--

TEMPERATURE / °F or °C	AIR	TRACK
-------------------------------	-----	-------

QUALIFYING POSITION	BEST LAPTIME / sec	FINAL POSITION	RACE LENGTH / minutes
6	10.4	7	8

TRACK CONDITION	<input checked="" type="checkbox"/> CARPET	<input type="checkbox"/> ASPHALT
	<input type="checkbox"/> TECHNICAL	<input type="checkbox"/> MIXED
	<input type="checkbox"/> FAST	<input checked="" type="checkbox"/> FAST

TRACTION	<input type="checkbox"/> LOW	<input type="checkbox"/> MEDIUM	<input checked="" type="checkbox"/> HIGH
-----------------	------------------------------	---------------------------------	--

SHOCK ABSORBER	
SPRING	Stk
OIL / cSt	600
REBOUND %	50

FRONT	TIRES	REAR
Jaco Lilac		Jaco Orange
40.5	DIAMETER/mm	42.5
Jack	ADDITIVE	Jack
10 Min	ADDITIVE timing	10 Min

FRONT LEFT	FRONT RIGHT	REAR LEFT	REAR RIGHT
ADDITIVE TREATED AREA			

TRANSMISSION	
DIFF SETTING	
<input type="checkbox"/> LOOSE	<input type="checkbox"/> MEDIUM
<input checked="" type="checkbox"/> TIGHT	<input type="checkbox"/>

PINION / T	43	SPUR GEAR /T	74
FINAL DRIVE RATIO	2.926	ROLLOUT	43.462

BRUSHED MOTOR	
BRAND	
ARMATURE	
	<input checked="" type="checkbox"/> SPRING
	<input checked="" type="checkbox"/> BRUSH COMP.

BRUSHLESS MOTOR	
BRAND	EAMotorsports Duo
TURN	17.5
ROTOR	12.5mm
TIMING	10 Degree

ESC	LRP SPX	
ESC SETTING	PROGRAM	2
	PUNCH	7
	INITIAL BRAKE	3
	AUTO BRAKE	4

BATTERIES	SMC Energy-4600	
BODY	Parma Speed 8HD	

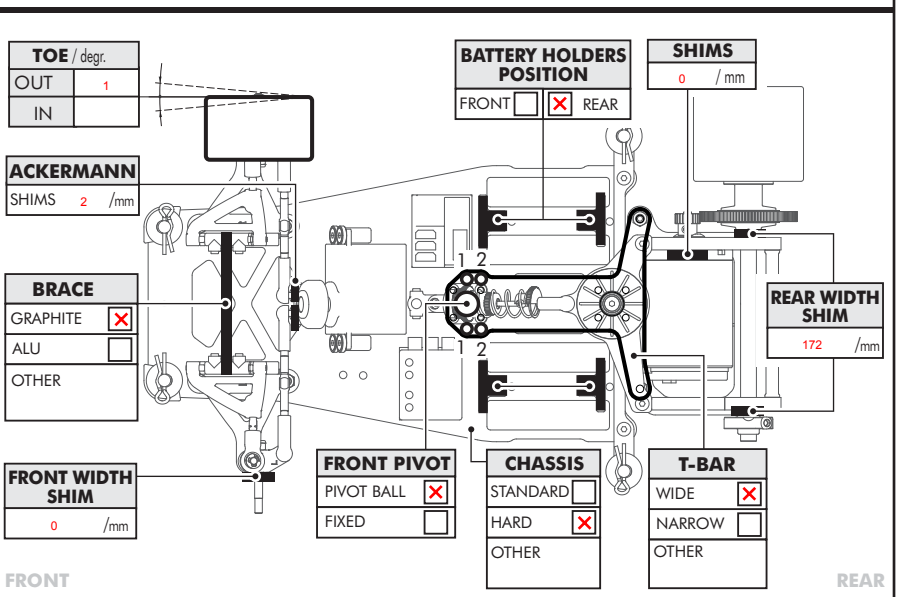
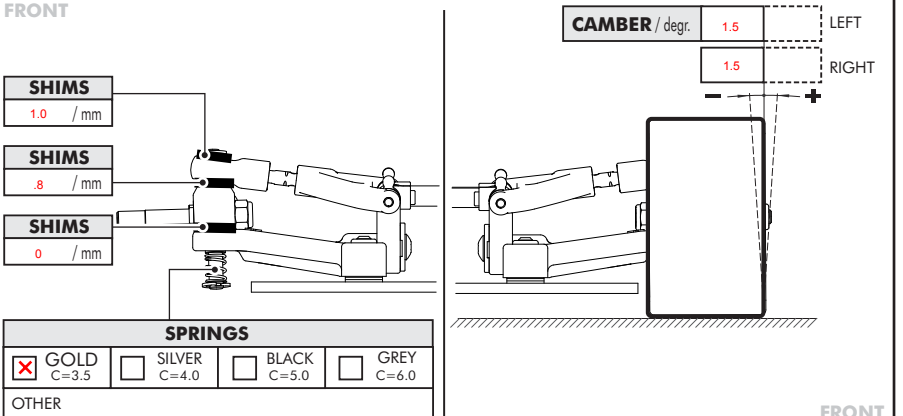
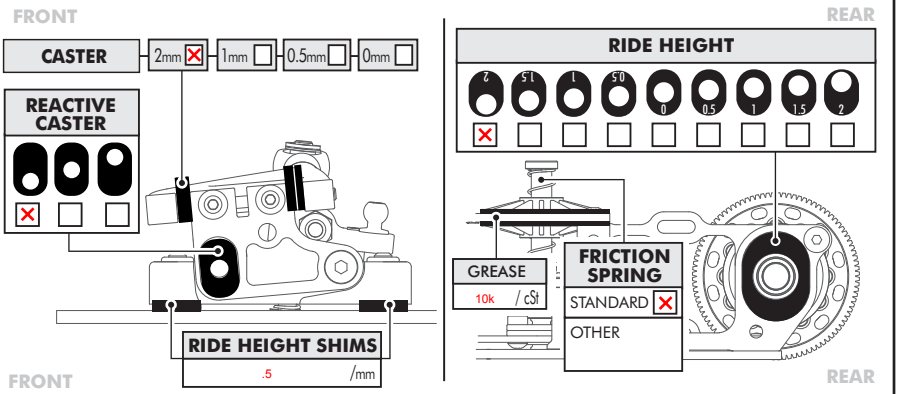
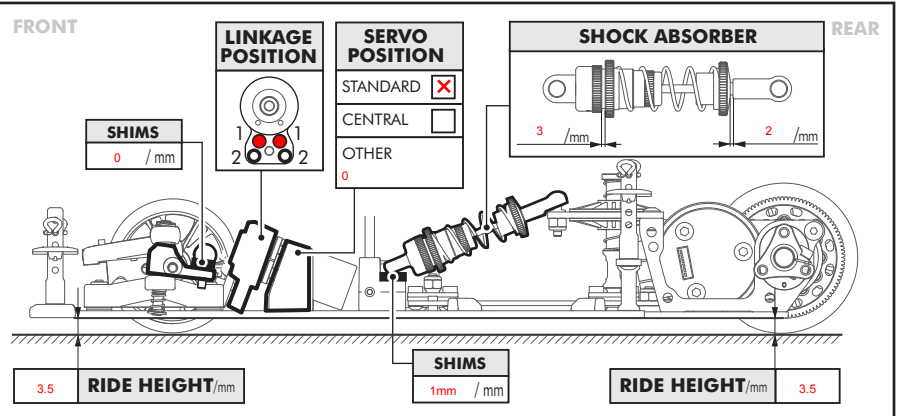

COMMENTS

Car had 1mm of uptravel in the shock under rear of chassis when picking up from ride height. Very easy to drive but needed a little more work for corner speed. Overall very good for 1 week of time on a brand new car!