

SET-UP SHEET

RACE	CS-Cup 5	
TRACK	Indoor Braunschweig	

NAME	Christian Schamp	
CITY / COUNTRY	Braunschweig	Germany
CONTACT	c.schamp@t-online.de	

DATE	15/03/2009	
-------------	------------	--

TEMPERATURE / °F or °C	AIR	TRACK
-------------------------------	-----	-------

QUALIFYING POSITION	BEST LAPTIME / sec	FINAL POSITION	RACE LENGTH / minutes
1	10.43	1	8

TRACK CONDITION	<input checked="" type="checkbox"/> CARPET	<input type="checkbox"/> ASPHALT
	<input type="checkbox"/> TECHNICAL	<input type="checkbox"/> MIXED
	<input type="checkbox"/> FAST	

TRACTION	<input type="checkbox"/> LOW	<input type="checkbox"/> MEDIUM	<input checked="" type="checkbox"/> HIGH
-----------------	------------------------------	---------------------------------	--

SHOCK ABSORBER	
SPRING	
OIL / cSt	250
REBOUND %	50

FRONT		REAR	
Jaco Pink	TIRES	Jaco Yellow	
43	DIAMETER/mm	45	
CS High	ADDITIVE	CS High	
20	ADDITIVE timing	40	
FRONT LEFT	FRONT RIGHT	REAR LEFT	REAR RIGHT
ADDITIVE TREATED AREA			

TRANSMISSION	
DIFF SETTING	
<input type="checkbox"/> LOOSE	<input type="checkbox"/> MEDIUM
<input checked="" type="checkbox"/> TIGHT	<input type="checkbox"/>

PINION / T	36	SPUR GEAR /T	96
FINAL DRIVE RATIO	4.533	ROLLOUT	29.786

BRUSHED MOTOR	
BRAND	
ARMATURE	
	<input checked="" type="checkbox"/> SPRING
	<input checked="" type="checkbox"/> BRUSH COMP.

BRUSHLESS MOTOR	
BRAND	CS
TURN	9.5T
ROTOR	12.5
TIMING	

ESC	
ESC SETTING	
PROGRAM	2
PUNCH	8
INITIAL BRAKE	0
AUTO BRAKE	0

BATTERIES	CS 4600 MCS
BODY	PF Speed 12

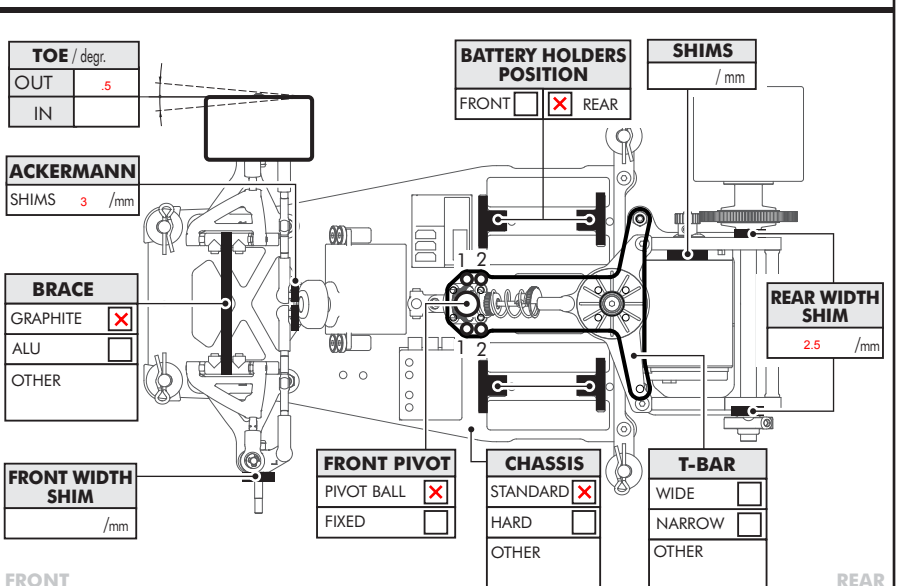
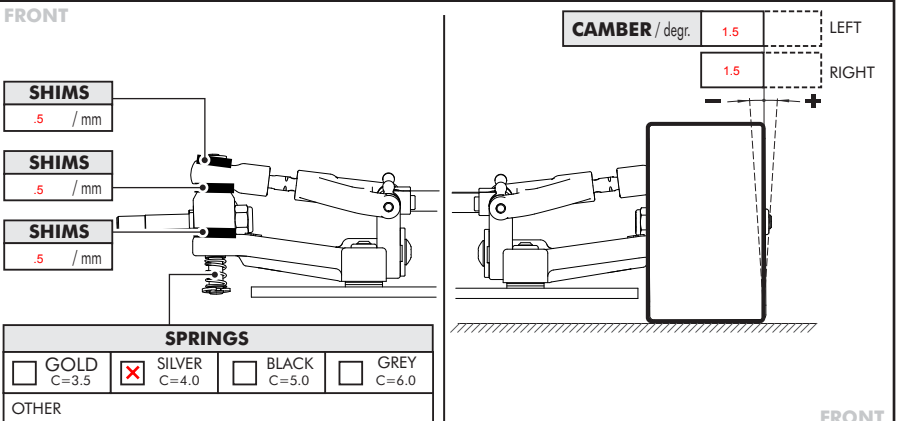
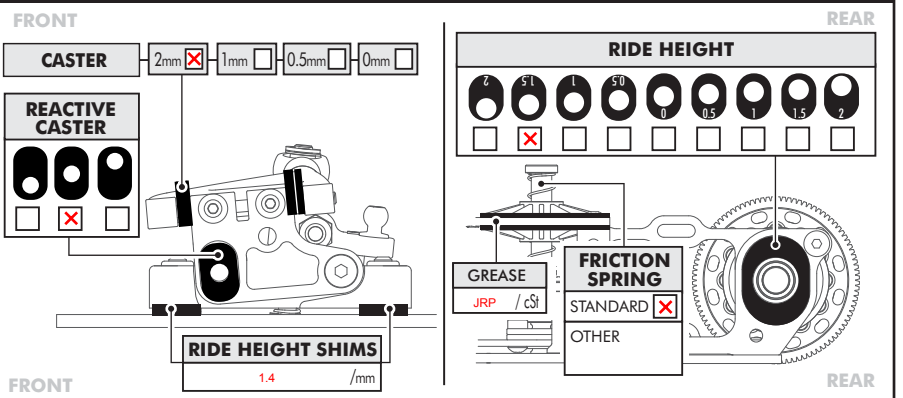
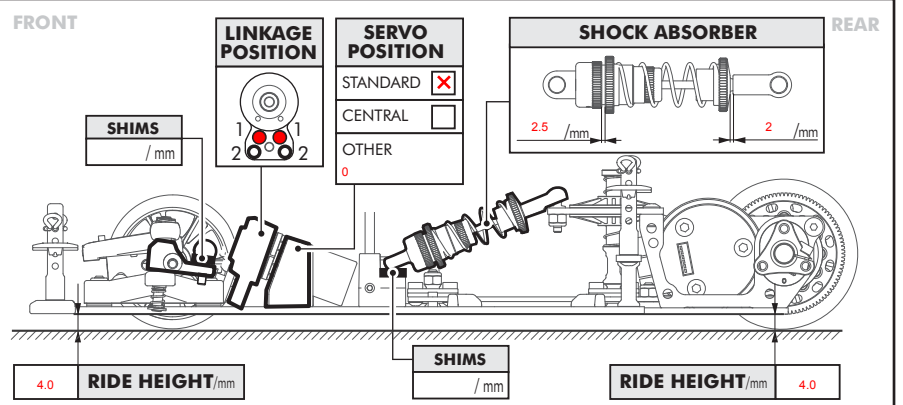

COMMENTS