

SET-UP SHEET

RACE	European 1/12th Championship	
TRACK	Hinckley, England	

NAME	Charlie Ware	
CITY / COUNTRY	Wellingborough	UK
CONTACT	charlie.ware@talktalk.net	

DATE	09/03/2010	
-------------	------------	--

TEMPERATURE / °F or °C	AIR	TRACK
-------------------------------	-----	-------

QUALIFYING POSITION	BEST LAPTIME / sec	FINAL POSITION	RACE LENGTH / minutes
B7		B2	8

TRACK CONDITION	<input checked="" type="checkbox"/> CARPET	<input type="checkbox"/> ASPHALT
	<input type="checkbox"/> TECHNICAL	<input checked="" type="checkbox"/> MIXED
	<input type="checkbox"/> FAST	

TRACTION	<input type="checkbox"/> LOW	<input type="checkbox"/> MEDIUM	<input checked="" type="checkbox"/> HIGH
-----------------	------------------------------	---------------------------------	--

SHOCK ABSORBER	
SPRING	kit
OIL / cSt	XRAY 350
REBOUND %	50

FRONT		TIRES	REAR	
Jaco Magenta			Jaco Magenta	
41.5		DIAMETER/mm	43	
CS High Grip		ADDITIVE	CS High Grip	
20 mins		ADDITIVE timing	10 mins	
FRONT LEFT	FRONT RIGHT	ADDITIVE TREATED AREA	REAR LEFT	REAR RIGHT

TRANSMISSION		
DIFF SETTING		
<input type="checkbox"/> LOOSE	<input type="checkbox"/> MEDIUM	<input checked="" type="checkbox"/> TIGHT

PINION / T		SPUR GEAR /T	
FINAL DRIVE RATIO		ROLLOUT	0

BRUSHED MOTOR	
BRAND	
ARMATURE	
	<input checked="" type="checkbox"/> SPRING
	<input checked="" type="checkbox"/> BRUSH COMP.

BRUSHLESS MOTOR	
BRAND	LRP X12
TURN	10.5
ROTOR	12.5mm
TIMING	std

ESC	LRP SXX Stock Spec			
ESC SETTING	PROGRAM	5	PUNCH	6
	INITIAL BRAKE	0	AUTO BRAKE	0

BATTERIES	LRP Big Mama
BODY	Parma Zytex

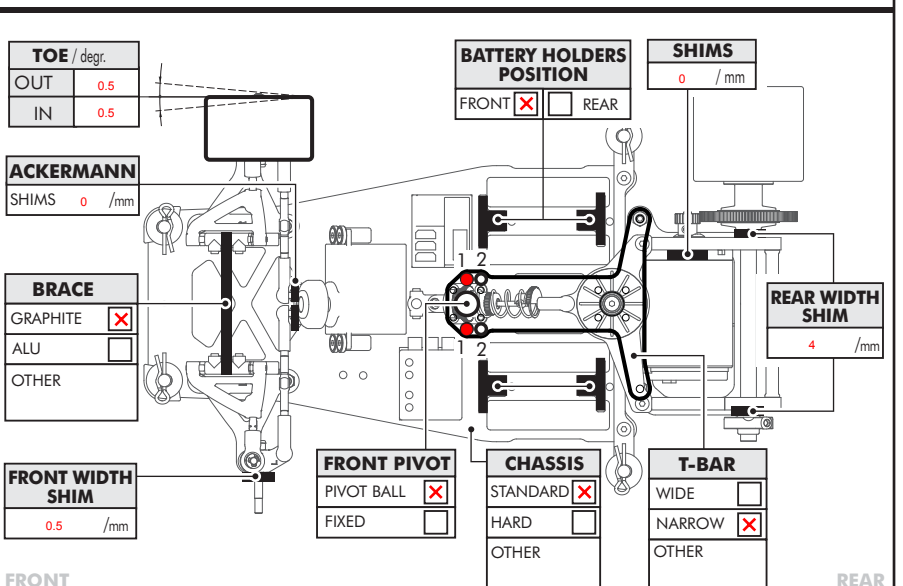
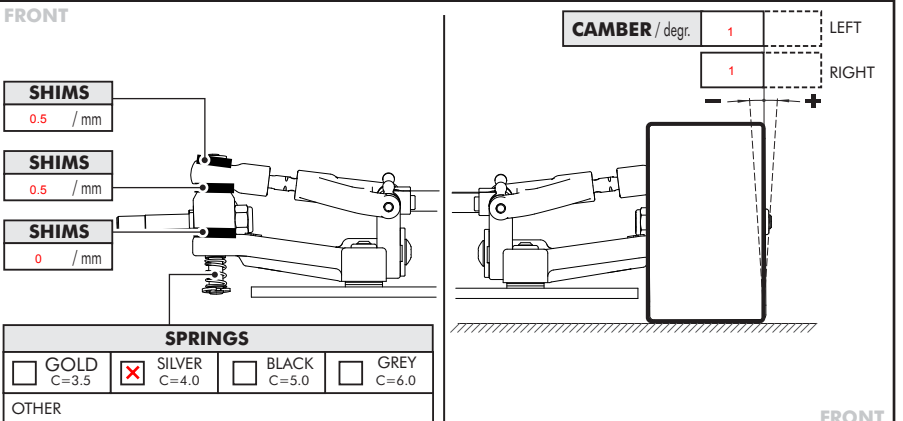
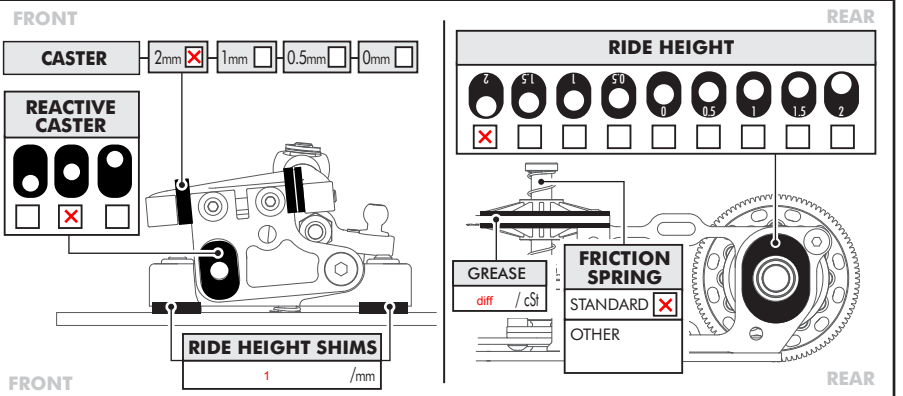
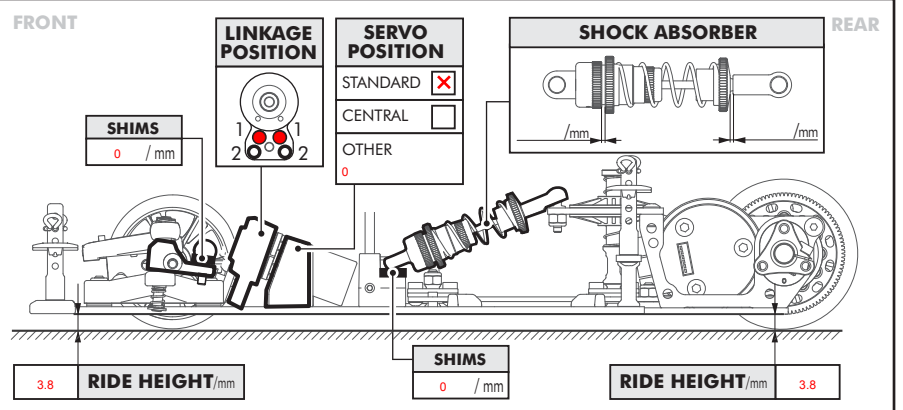

COMMENTS

car handled really well, used maximum turning circle in finals.
Also changed to Protoform AMR 12 Shell.

Pod Droop - 1mm