

SET-UP SHEET

RACE	EC Hinckley	
TRACK	EC Hinckley	

NAME	mathias.rascol	
CITY / COUNTRY	Nantes	France
CONTACT	mathias.rascol@gmail.com	

DATE	07/03/2010	
TEMPERATURE / °C	AIR	TRACK

QUALIFYING POSITION	BEST LAPTIME / sec	FINAL POSITION	RACE LENGTH / minutes
27	12'41	27	8

TRACK CONDITION	<input checked="" type="checkbox"/> CARPET	<input type="checkbox"/> ASPHALT
	<input type="checkbox"/> TECHNICAL	<input checked="" type="checkbox"/> MIXED
	<input type="checkbox"/> FAST	<input checked="" type="checkbox"/> HIGH

TRACTION	<input type="checkbox"/> LOW	<input type="checkbox"/> MEDIUM	<input checked="" type="checkbox"/> HIGH
-----------------	------------------------------	---------------------------------	--

CENTER SHOCK ABSORBER			
SPRING	std	OIL / cSt	450
		REBOUND %	25

SIDE SHOCK ABSORBER			
	OIL / cSt	250	

FRONT	TIRES	REAR	
Magenta		Magenta	
41	DIAMETER/mm	43	
CS High Grip	ADDITIVE	CS High Grip	
15	ADDITIVE timing	30	
FRONT LEFT	FRONT RIGHT	REAR LEFT	REAR RIGHT
ADDITIVE TREATED AREA			

TRANSMISSION	
DIFF SETTING	
<input type="checkbox"/> LOOSE	<input type="checkbox"/> MEDIUM
<input type="checkbox"/> TIGHT	

PINION / T	23	SPUR GEAR/T	96
FINAL DRIVE RATIO	4.1739130434783	ROLLOUT	32.348541666667

BRUSHED MOTOR	
BRAND	
ARMATURE	

BRUSHLESS MOTOR	
BRAND	Novak
TURN	3.5
ROTOR	
TIMING	0

ESC	Novak GTB 4cells	
ESC SETTING	PROGRAM	<input type="checkbox"/> PUNCH
	INITIAL BRAKE	<input type="checkbox"/> AUTO BRAKE
BATTERIES	SMC 5300 1S	
BODY	Parma EE1	

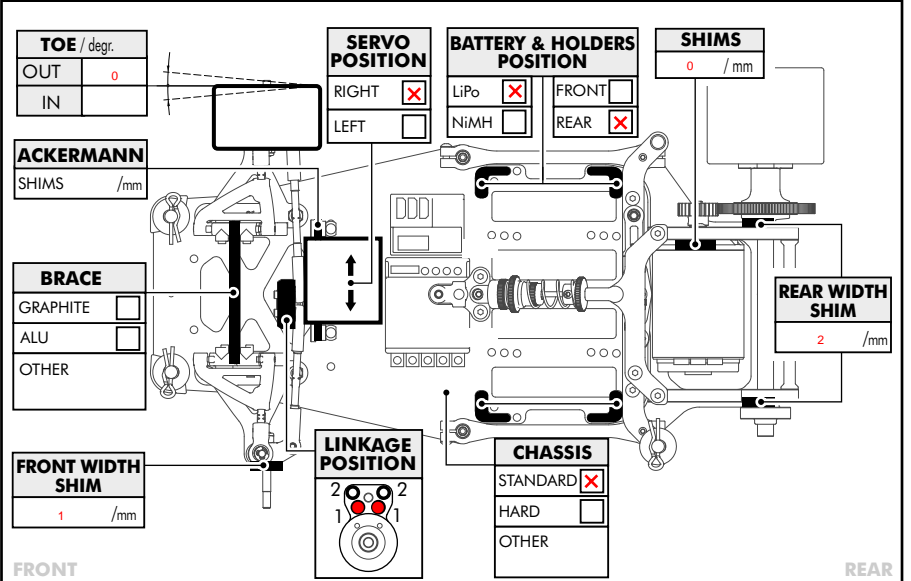
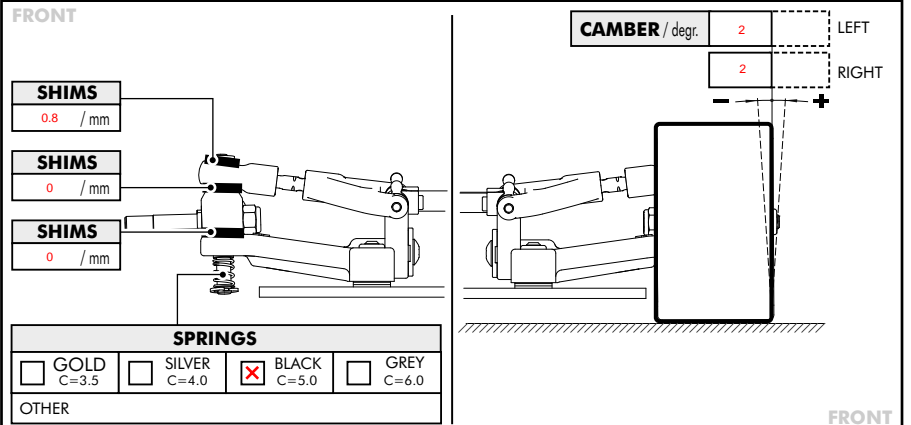
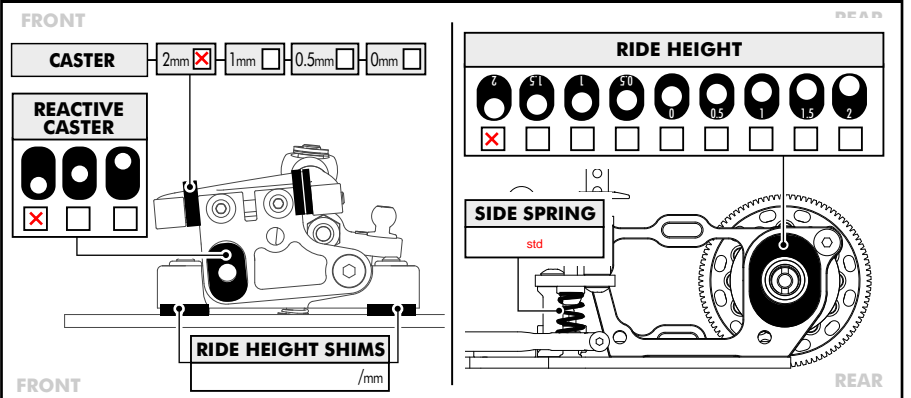
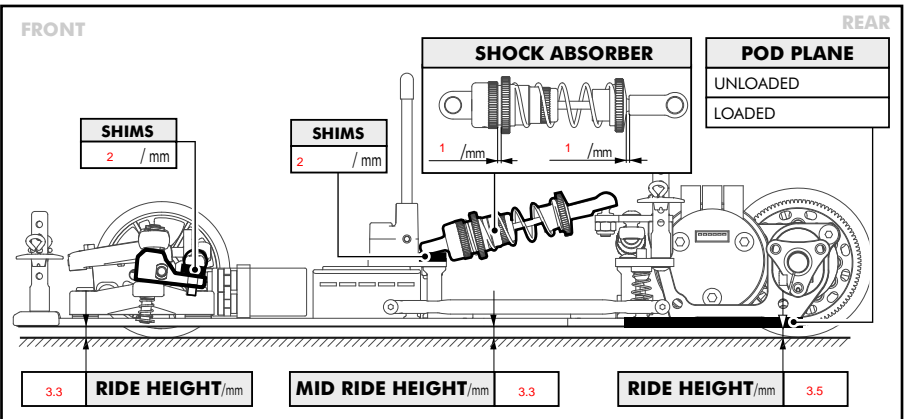

COMMENTS