

SET-UP SHEET

RACE	2014 ACT Indoor Titles	
TRACK	EPIC, Fitzroy	

NAME	nerdling	
CITY / COUNTRY	Canberra	Australia
CONTACT	mark.wallin@actmrc.org.au	

DATE	29/06/2014			
TEMPERATURE / °C	AIR	10c	TRACK	10c

QUALIFYING POSITION	BEST LAPTIME / sec	FINAL POSITION	RACE LENGTH / minutes
1		2	

TRACK CONDITION	<input checked="" type="checkbox"/> CARPET	<input type="checkbox"/> ASPHALT
	<input type="checkbox"/> TECHNICAL	<input checked="" type="checkbox"/> MIXED
TRACTION	<input type="checkbox"/> LOW	<input checked="" type="checkbox"/> MEDIUM
		<input type="checkbox"/> HIGH

CENTER SHOCK ABSORBER			
SPRING	Pink	OIL / cSt	350
		REBOUND %	0

SIDE SHOCK ABSORBER			
	OIL / cSt	350	

FRONT		REAR	
Matrix 32	TIRES	Matrix 30	
43.2	DIAMETER/mm	46.2	
	ADDITIVE		
	ADDITIVE timing		
FRONT LEFT	FRONT RIGHT	REAR LEFT	REAR RIGHT
ADDITIVE TREATED AREA			

TRANSMISSION	
DIFF SETTING	
<input type="checkbox"/> LOOSE	<input checked="" type="checkbox"/> MEDIUM
<input type="checkbox"/>	<input type="checkbox"/> TIGHT

PINION / T	27	SPUR GEAR/T	96
FINAL DRIVE RATIO	3.5555555555556	ROLLOUT	40.800375

BRUSHED MOTOR	
BRAND	
ARMATURE	

BRUSHLESS MOTOR	
BRAND	Nosram
TURN	4.5
ROTOR	
TIMING	4dot

ESC	Nosram	
ESC SETTING	PROGRAM <input type="checkbox"/>	PUNCH <input type="checkbox"/>
	INITIAL BRAKE <input type="checkbox"/>	AUTO BRAKE <input type="checkbox"/>
BATTERIES	Nosram 6700	
BODY	Parma Speed 8 HD	

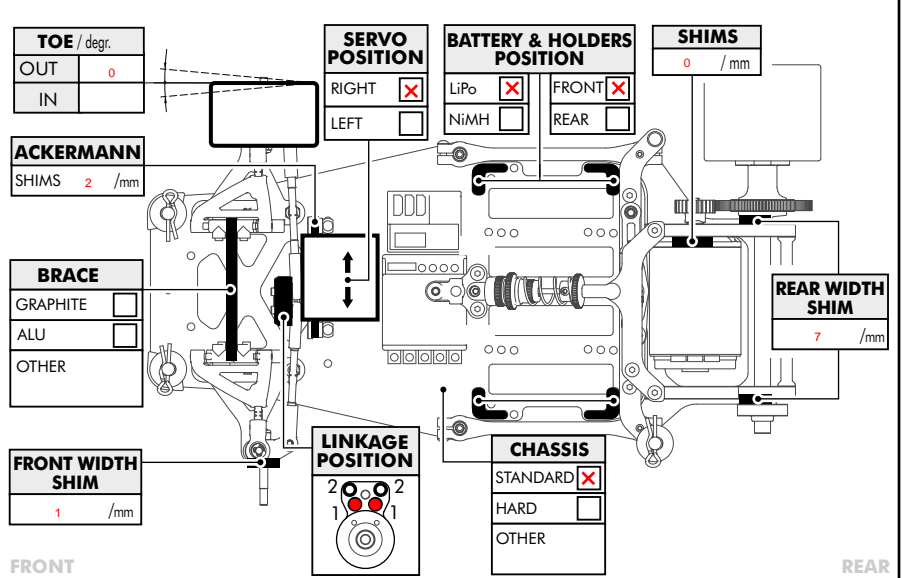
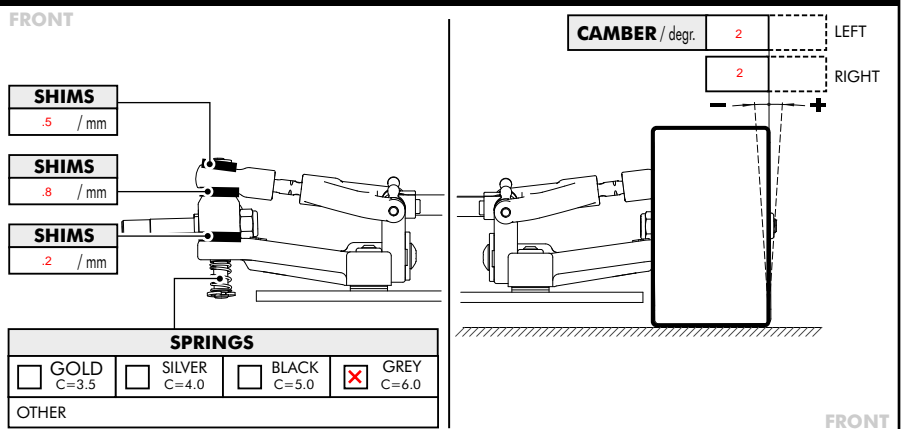
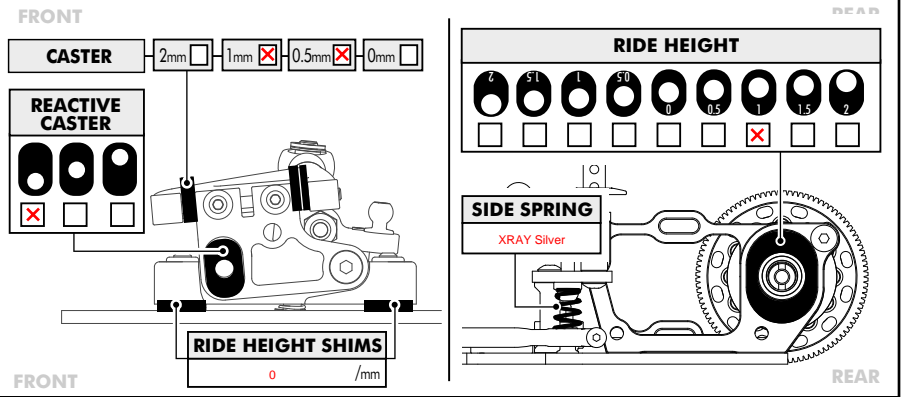
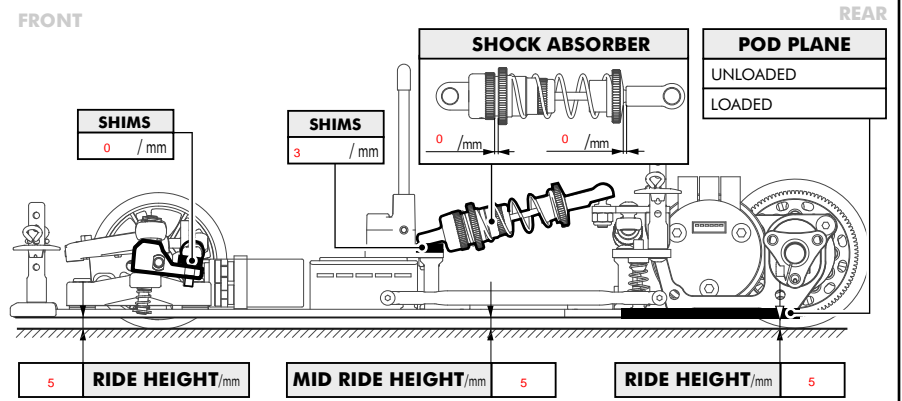

COMMENTS
Was geared right on the edge for runtime.