

# SET-UP SHEET

|              |                  |  |
|--------------|------------------|--|
| <b>RACE</b>  | IIC              |  |
| <b>TRACK</b> | Riviera Ballroom |  |

|                       |                             |     |
|-----------------------|-----------------------------|-----|
| <b>NAME</b>           | Alexander Hagberg           |     |
| <b>CITY / COUNTRY</b> | Las Vegas, NV               | USA |
| <b>CONTACT</b>        | alexander.hagberg@gmail.com |     |

|                               |            |       |
|-------------------------------|------------|-------|
| <b>DATE</b>                   | 16/10/2011 |       |
| <b>TEMPERATURE / °F or °C</b> | AIR        | TRACK |

|                            |                            |                       |                              |
|----------------------------|----------------------------|-----------------------|------------------------------|
| <b>QUALIFYING POSITION</b> | <b>BEST LAP TIME / sec</b> | <b>FINAL POSITION</b> | <b>RACE LENGTH / minutes</b> |
| 9                          |                            | 5                     | 8                            |

|                        |  |                                  |
|------------------------|--|----------------------------------|
| <b>TRACK CONDITION</b> | <input checked="" type="checkbox"/> CARPET | <input type="checkbox"/> ASPHALT |
|                        | <input type="checkbox"/> TECHNICAL         | <input type="checkbox"/> FAST    |
| <b>TRACTION</b>        |  |                                  |
|                        | <input type="checkbox"/> LOW               | <input type="checkbox"/> MEDIUM  |
|                        | <input checked="" type="checkbox"/> HIGH   |                                  |

|                              |      |                  |     |
|------------------------------|------|------------------|-----|
| <b>CENTER SHOCK ABSORBER</b> |      |                  |     |
| <b>SPRING</b>                | Gold | <b>OIL / cSt</b> | 550 |
|                              |      | <b>REBOUND %</b> | 50  |

|                            |                  |  |  |
|----------------------------|------------------|--|--|
| <b>SIDE SHOCK ABSORBER</b> |                  |  |  |
|                            | <b>OIL / cSt</b> |  |  |

|                              |                        |                  |                   |
|------------------------------|------------------------|------------------|-------------------|
| <b>FRONT</b>                 | <b>TIRES</b>           | <b>REAR</b>      |                   |
| Parma Magenta                |                        | Parma Magenta    |                   |
| 39.5                         | <b>DIAMETER / mm</b>   | 41.5             |                   |
| Jack The Gripper             | <b>ADDITIVE</b>        | Jack The Gripper |                   |
| 5                            | <b>ADDITIVE timing</b> | 10               |                   |
| <b>FRONT LEFT</b>            | <b>FRONT RIGHT</b>     | <b>REAR LEFT</b> | <b>REAR RIGHT</b> |
|                              |                        |                  |                   |
| <b>ADDITIVE TREATED AREA</b> |                        |                  |                   |

|   |                                 |
|---|---------------------------------|
| <b>TRANSMISSION</b>                       |                                 |
| <b>DIFF SETTING</b>                       |                                 |
| <input type="checkbox"/> LOOSE            | <input type="checkbox"/> MEDIUM |
| <input checked="" type="checkbox"/> TIGHT | <input type="checkbox"/>        |

|                          |                 |                      |                 |
|--------------------------|-----------------|----------------------|-----------------|
| <b>PINION / T</b>        | 26              | <b>SPUR GEAR / T</b> | 96              |
| <b>FINAL DRIVE RATIO</b> | 3.6923076923077 | <b>ROLLOUT</b>       | 35.292291666667 |

|                      |  |
|----------------------|--|
| <b>BRUSHED MOTOR</b> |  |
| <b>BRAND</b>         |  |
| <b>ARMATURE</b>      |  |

|                        |              |
|------------------------|--------------|
| <b>BRUSHLESS MOTOR</b> |              |
| <b>BRAND</b>           | LRP X12      |
| <b>TURN</b>            | 4.0T         |
| <b>ROTOR</b>           | 12.5mm Works |
| <b>TIMING</b>          | 0000         |

|                    |                          |                   |
|--------------------|--------------------------|-------------------|
| <b>ESC</b>         | LRP SXX Version2         |                   |
| <b>ESC SETTING</b> | <b>PROGRAM</b>           | <b>PUNCH</b>      |
|                    | <input type="checkbox"/> | 3-5               |
|                    | <b>INITIAL BRAKE</b>     | <b>AUTO BRAKE</b> |
|                    | <input type="checkbox"/> | 1                 |
| <b>BATTERIES</b>   | LRP 5800                 |                   |
| <b>BODY</b>        | Protoform AMR-12         |                   |

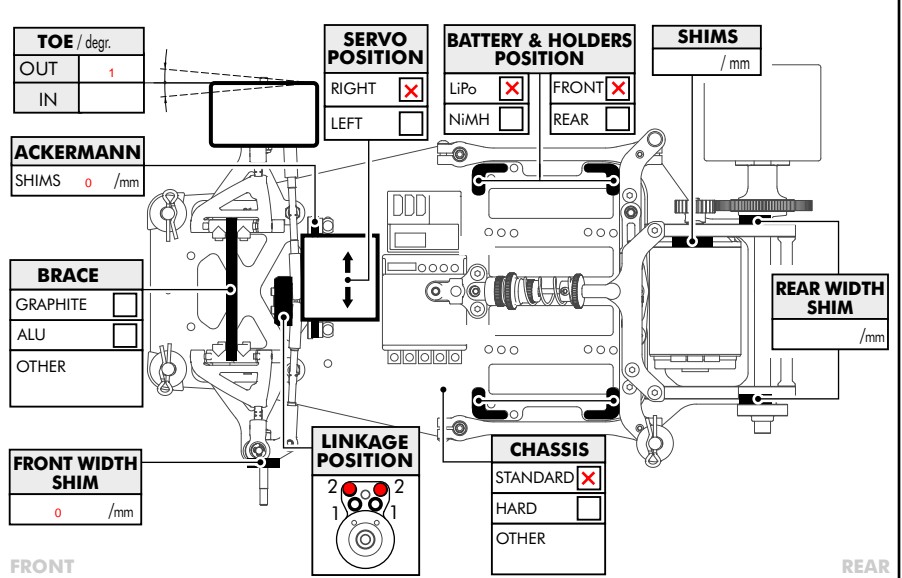
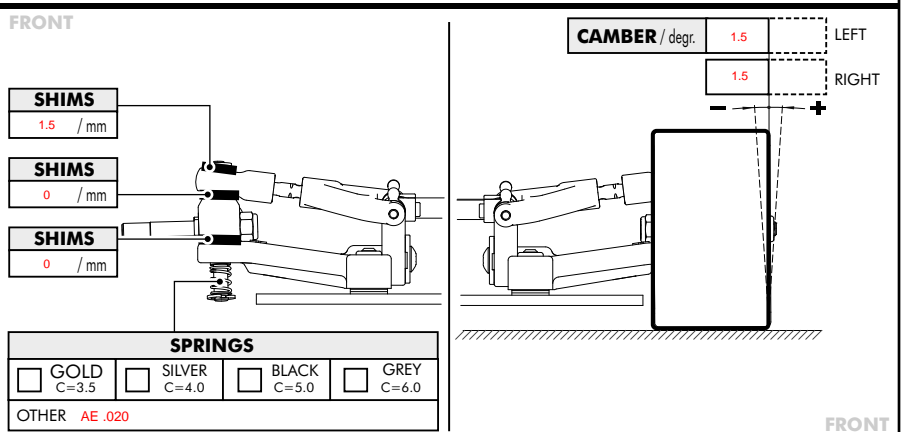
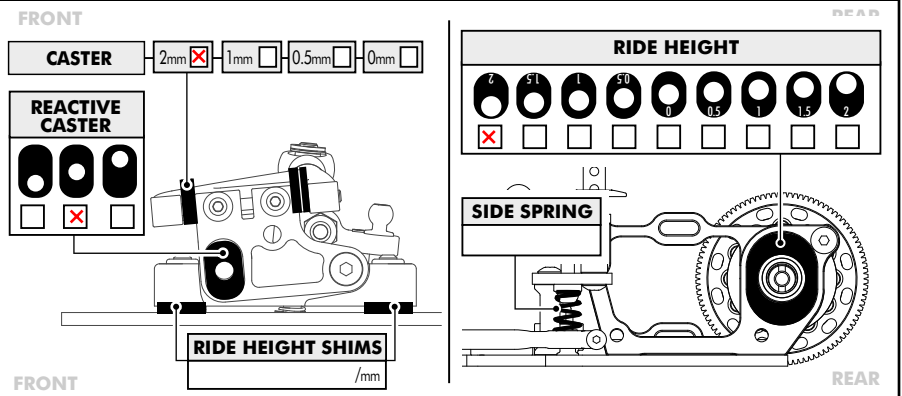
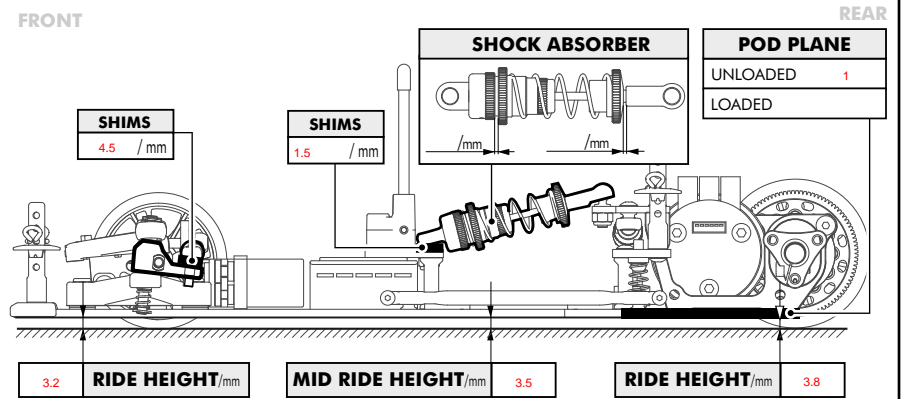

**COMMENTS**

Glued one hole in the shock piston for heavier damping.

Speedmerchant linear side springs .020. Little or no preload.

10K front kingpin lube.