

SET-UP SHEET

RACE	Euros	
TRACK	Hinckley Leisure Center	

NAME	Alexander Hagberg	
CITY / COUNTRY	Hinckley	UK
CONTACT	alexander.hagberg@gmail.com	

DATE	08/03/2010	
TEMPERATURE / °C	AIR	TRACK

QUALIFYING POSITION	BEST LAPTIME / sec	FINAL POSITION	RACE LENGTH / minutes
9	12.9	7	8

TRACK CONDITION	<input checked="" type="checkbox"/> CARPET	<input type="checkbox"/> ASPHALT
	<input type="checkbox"/> TECHNICAL	<input checked="" type="checkbox"/> MIXED
TRACTION	<input type="checkbox"/> LOW	<input checked="" type="checkbox"/> MEDIUM
		<input type="checkbox"/> HIGH

CENTER SHOCK ABSORBER			
SPRING	Kit	OIL / cSt	350
		REBOUND %	

SIDE SHOCK ABSORBER			
	OIL / cSt	350	

FRONT		REAR	
Parma Magenta	TIRES	Parma Magenta	
40.5	DIAMETER/mm	42.5	
CS HG	ADDITIVE	CS HG	
10	ADDITIVE timing	20	
FRONT LEFT	FRONT RIGHT	REAR LEFT	REAR RIGHT
ADDITIVE TREATED AREA			

TRANSMISSION	
DIFF SETTING	
<input type="checkbox"/> LOOSE	<input type="checkbox"/> MEDIUM <input checked="" type="checkbox"/> TIGHT

PINION / T	25	SPUR GEAR/T	96
FINAL DRIVE RATIO	3.84	ROLLOUT	34.752604166667

BRUSHED MOTOR	
BRAND	
ARMATURE	

BRUSHLESS MOTOR	
BRAND	LRP X12
TURN	4.5T
ROTOR	12.5mm
TIMING	0000

ESC	LRP SXX StockSpec			
ESC SETTING	PROGRAM	0	PUNCH	3
	INITIAL BRAKE	1	AUTO BRAKE	0
BATTERIES	LRP VTEC 5300 50C			
BODY	Protoform AMR-12			

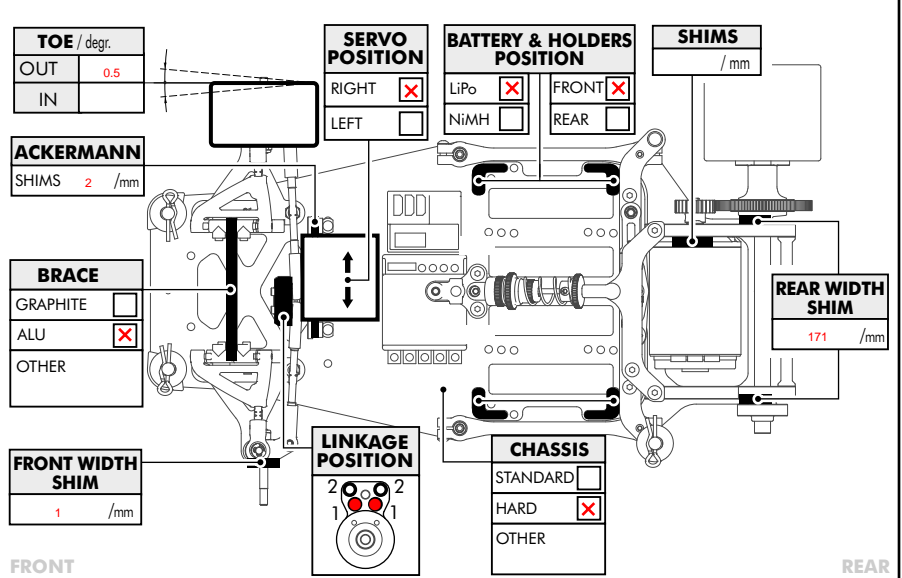
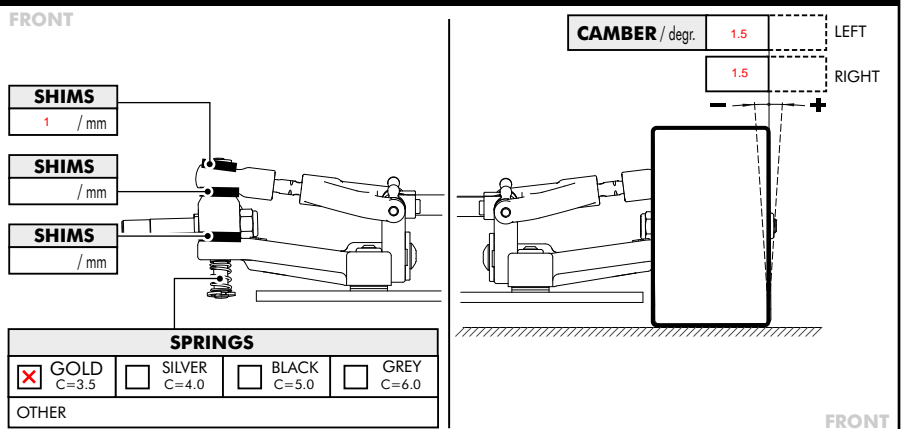
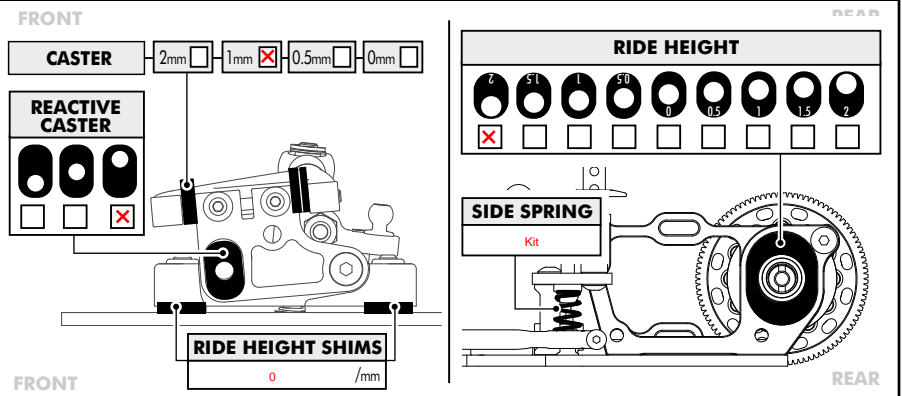
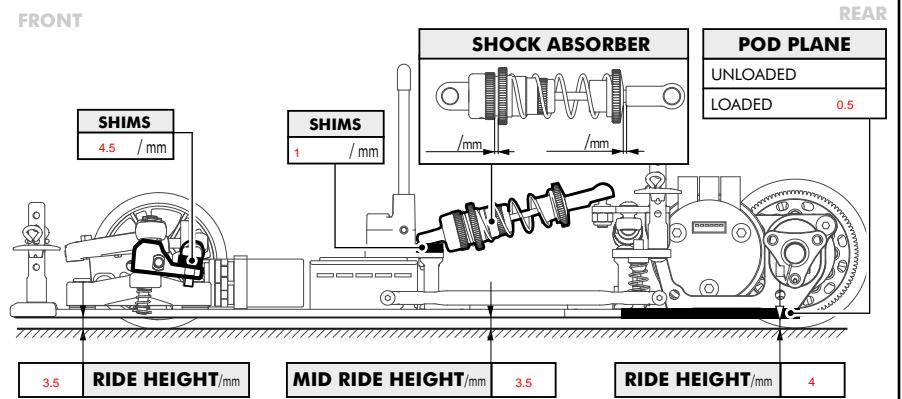

COMMENTS

24 grams of weight under LiPo