

Driver \_\_\_\_\_ Surface Asphalt (Indoor/Outdoor) Carpet Smooth Bumpy Track Temperature \_\_\_\_\_  
Date \_\_\_\_\_ Traction Low Medium High Dry Wet Result \_\_\_\_\_ Air Temperature \_\_\_\_\_  
Track \_\_\_\_\_ Country \_\_\_\_\_ Best Lap \_\_\_\_\_ Humidity \_\_\_\_\_ Remark \_\_\_\_\_

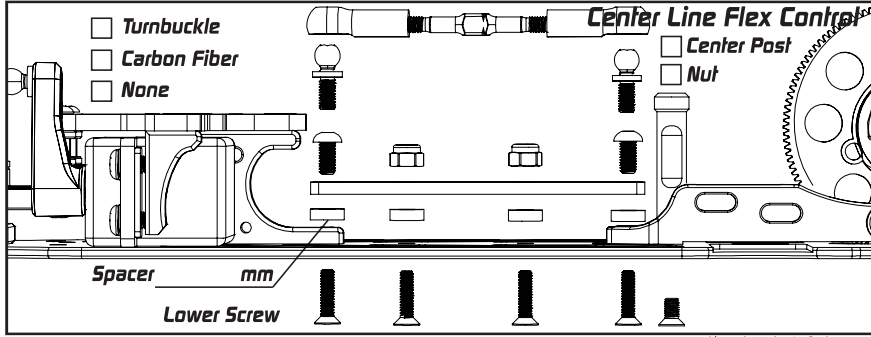
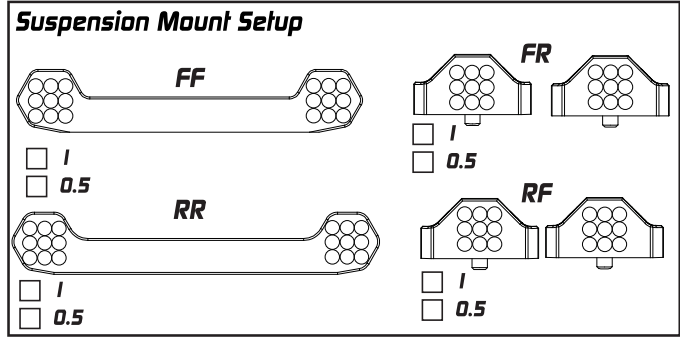
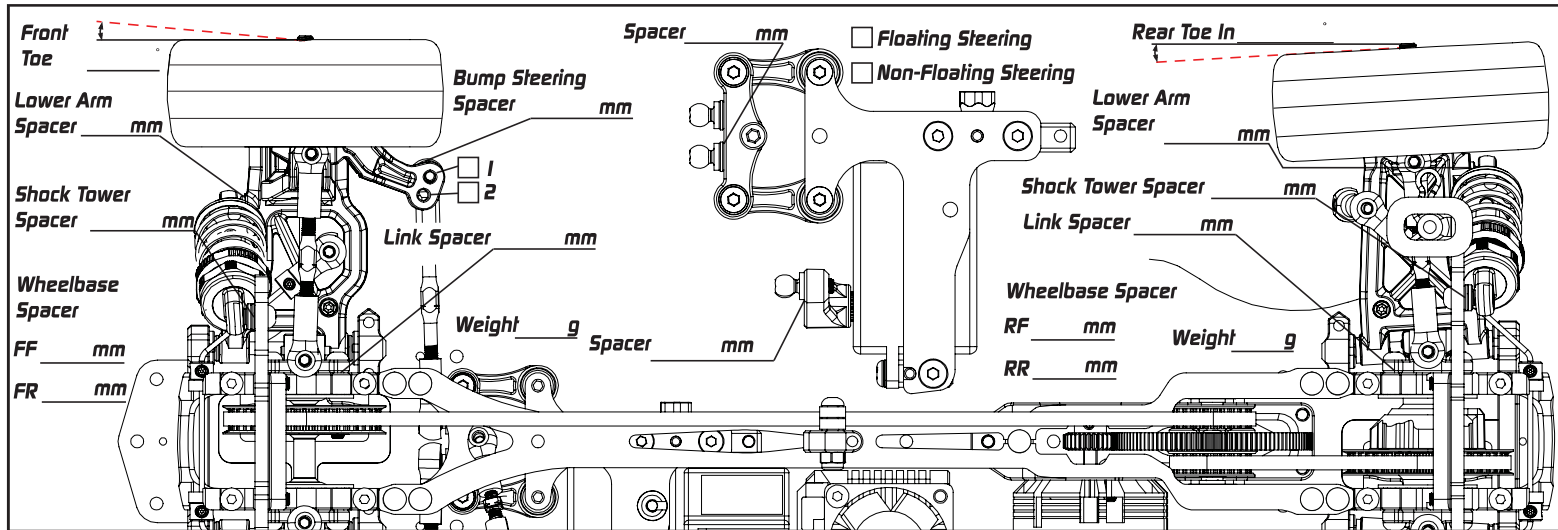
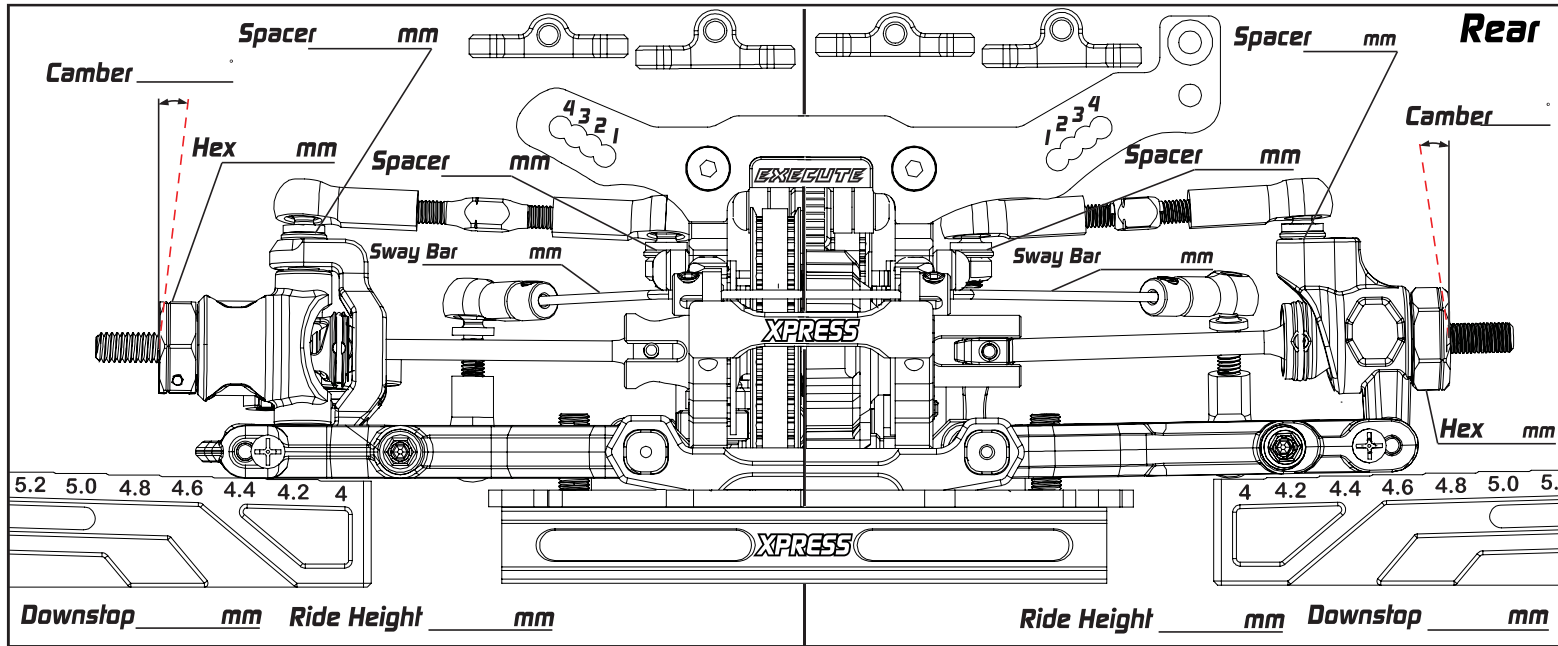

### Damper Setup

	Front	Rear
Spring	_____	_____
Oil	_____	_____
Rebound	_____	_____
Piston	_____	_____
Length	_____	_____
Foam Insert	<input type="checkbox"/>	<input type="checkbox"/>
Hole In Cap	<input type="checkbox"/>	<input type="checkbox"/>

### Transmission Setup

Front	Rear
Spool Gear Diff	Gear Diff
Oil _____	Oil _____
Weight _____ g	Weight _____ g
Position Low High	Position Low High

Servo _____	Tires _____
Esc _____	Additive _____
Motor _____	Body _____
Spur P/ _____	T Rear Wing _____
Pinon P/ _____	T FDR _____