

Driver _____ **Surface** Asphalt (Indoor/Outdoor) Carpet Smooth Bumpy **Track Temperature** _____
Date _____ **Traction** Low Medium High Dry Wet **Result** _____ **Air Temperature** _____
Track _____ **Country** _____ **Best Lap** _____ **Humidity** _____ **Remark** _____

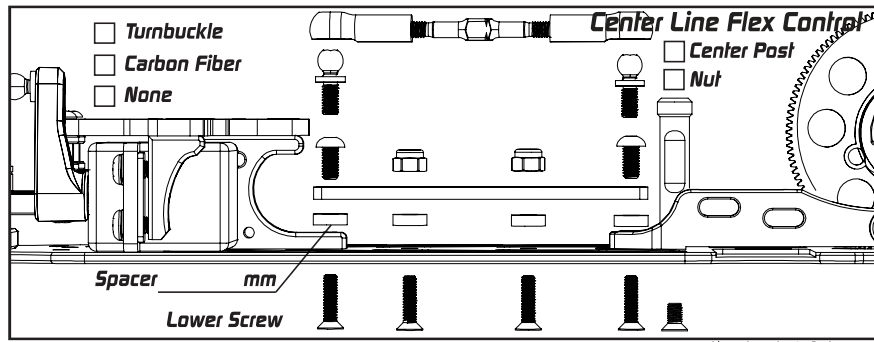
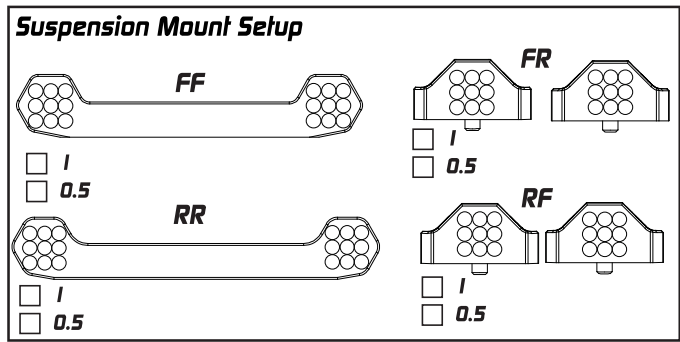
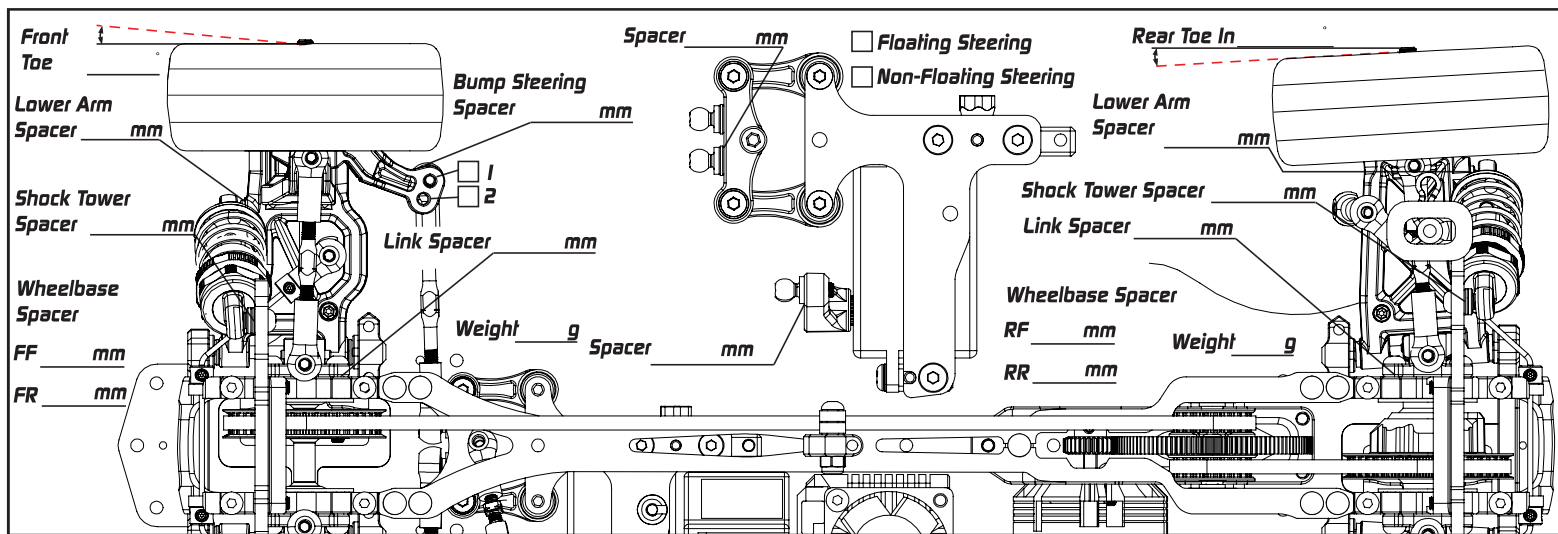
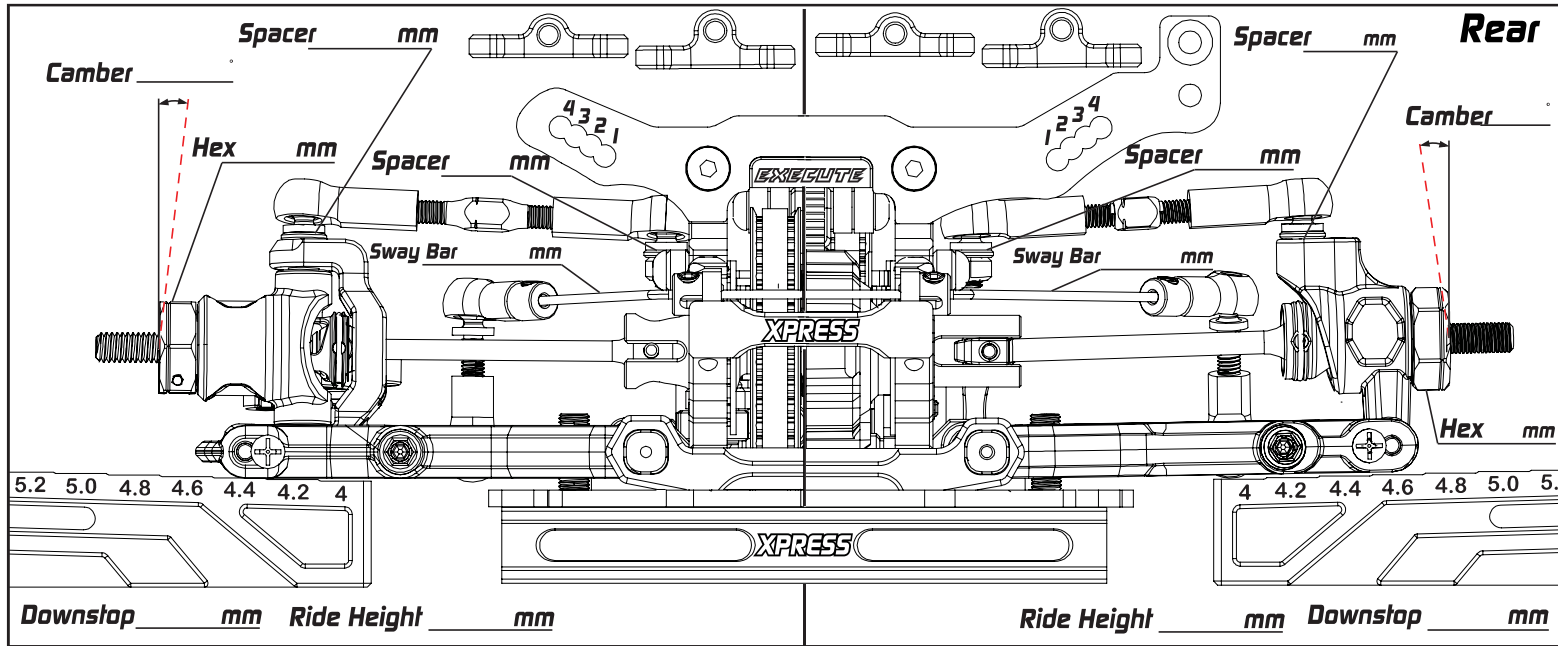

Damper Setup

	Front	Rear
Spring	_____	_____
Oil	_____	_____
Rebound	_____	_____
Piston	_____	_____
Length	_____	_____
Foam Insert	<input type="checkbox"/>	Foam Insert <input type="checkbox"/>
Hole In Cap	<input type="checkbox"/>	Hole In Cap <input type="checkbox"/>

Transmission Setup

Front	Rear
Spool Gear Diff	Gear Diff
Oil _____	Oil _____
Weight _____ g	Weight _____ g
Position Low High	Position Low High

Servo _____	Tires _____
Esc _____	Additive _____
Motor _____	Body _____
Spur P/ _____	T Rear Wing _____
Pinon P/ _____	T FDR _____