

Driver \_\_\_\_\_ Track Surface \_\_\_\_\_ Track Temperature \_\_\_\_\_  
 Date \_\_\_\_\_ Track Traction \_\_\_\_\_ Result \_\_\_\_\_ Air Temperature \_\_\_\_\_  
 Track \_\_\_\_\_ Country \_\_\_\_\_ Best Lap \_\_\_\_\_ Humidity \_\_\_\_\_ Remark \_\_\_\_\_

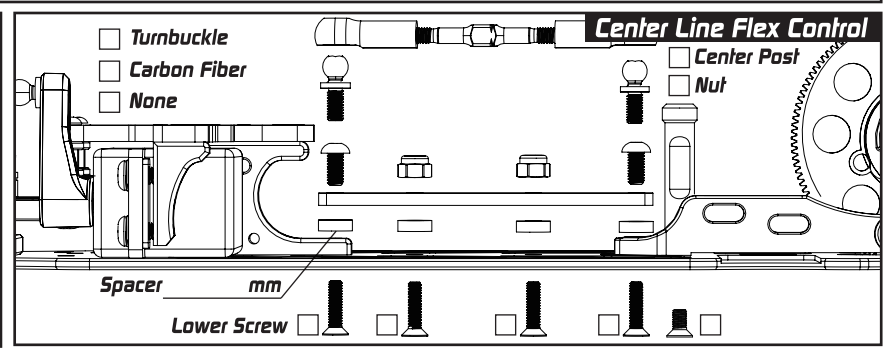
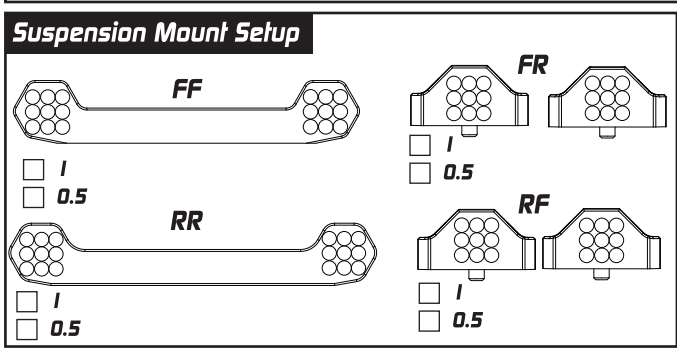
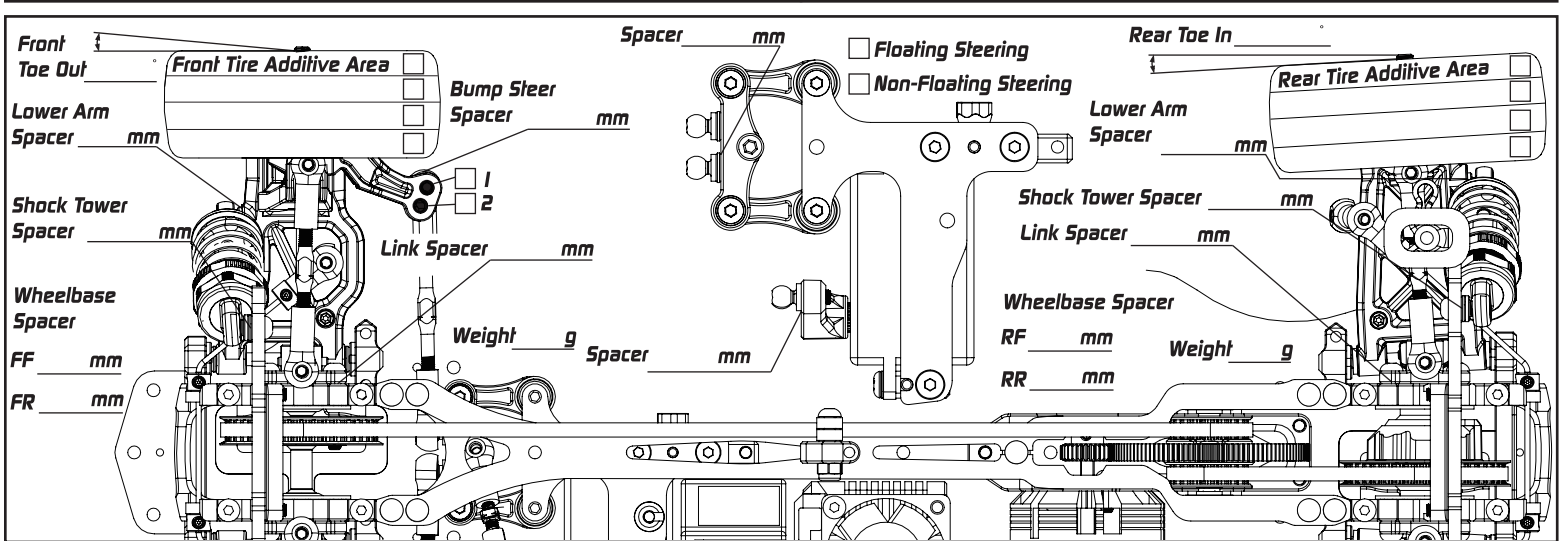
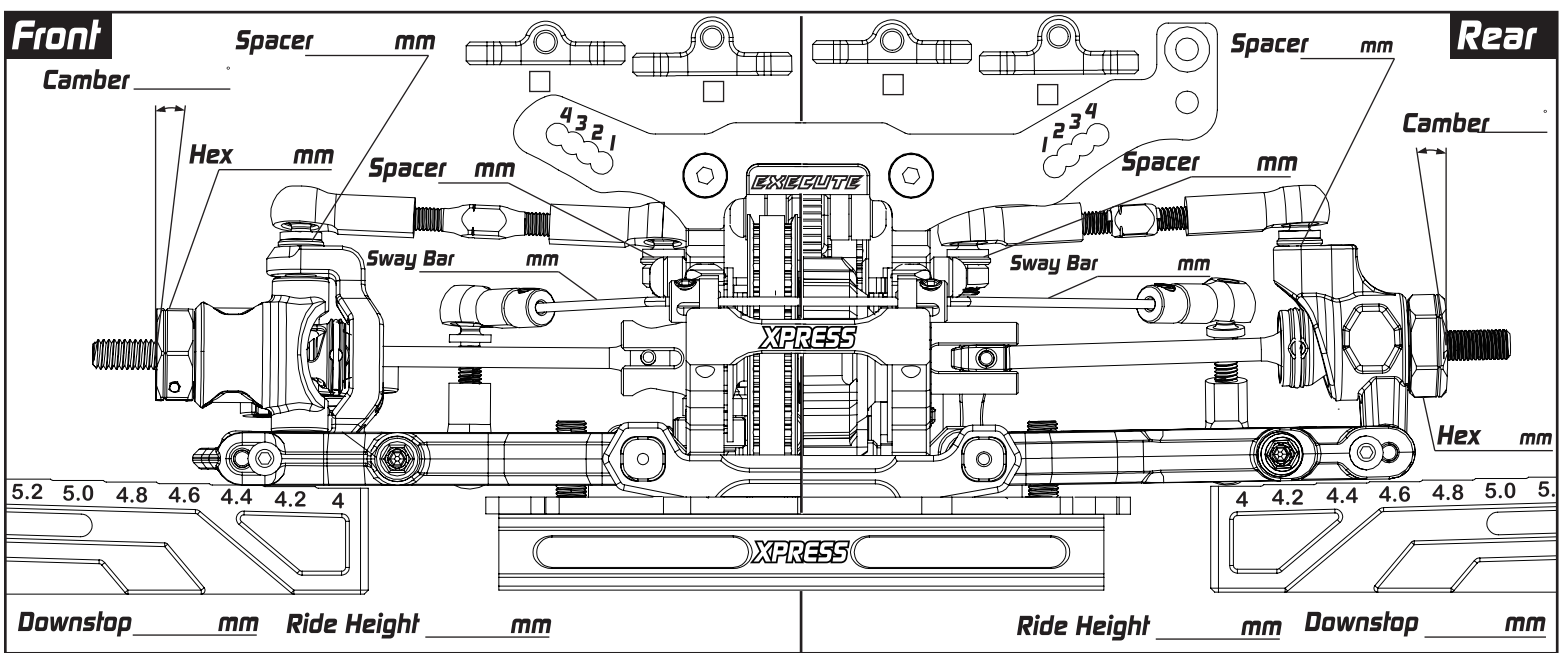

### Damper Setup

|             | Front                    | Rear                     |
|-------------|--------------------------|--------------------------|
| Spring      | _____                    | _____                    |
| Oil         | _____                    | _____                    |
| Rebound     | _____                    | _____                    |
| Piston      | _____                    | _____                    |
| Length      | _____                    | _____                    |
| Foam Insert | <input type="checkbox"/> | <input type="checkbox"/> |
| Hole In Cap | <input type="checkbox"/> | <input type="checkbox"/> |

### Transmission Setup

| Front     | Rear    |
|-----------|---------|
| Oil       | _____   |
| Weight    | _____ g |
| Position  | _____   |
| Gear Diff | _____   |
| Oil       | _____   |
| Weight    | _____ g |
| Position  | _____   |

### Others

Servo \_\_\_\_\_ Tires \_\_\_\_\_  
 Esc \_\_\_\_\_ Additive \_\_\_\_\_  
 Motor \_\_\_\_\_ Body \_\_\_\_\_  
 Spur P/ T Rear Wing \_\_\_\_\_  
 Pinon P/ T FDR \_\_\_\_\_