

Driver _____ Track Surface _____ Track Temperature _____
 Date _____ Track Traction _____ Result _____ Air Temperature _____
 Track _____ Country _____ Best Lap _____ Humidity _____ Remark _____

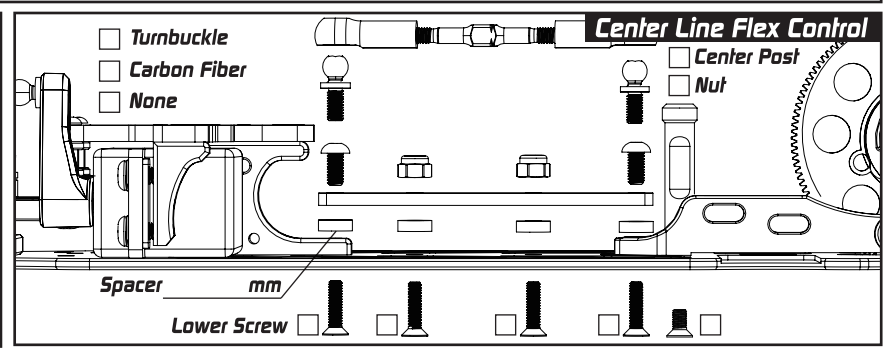
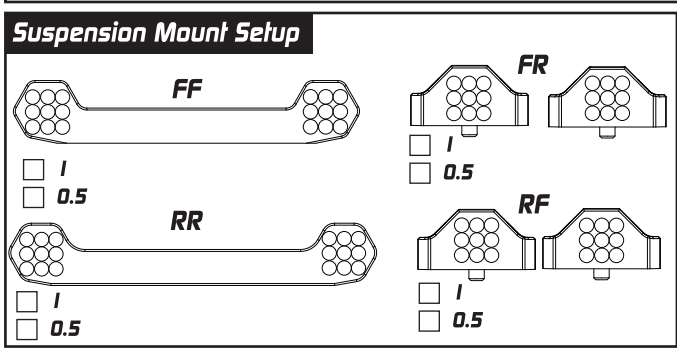
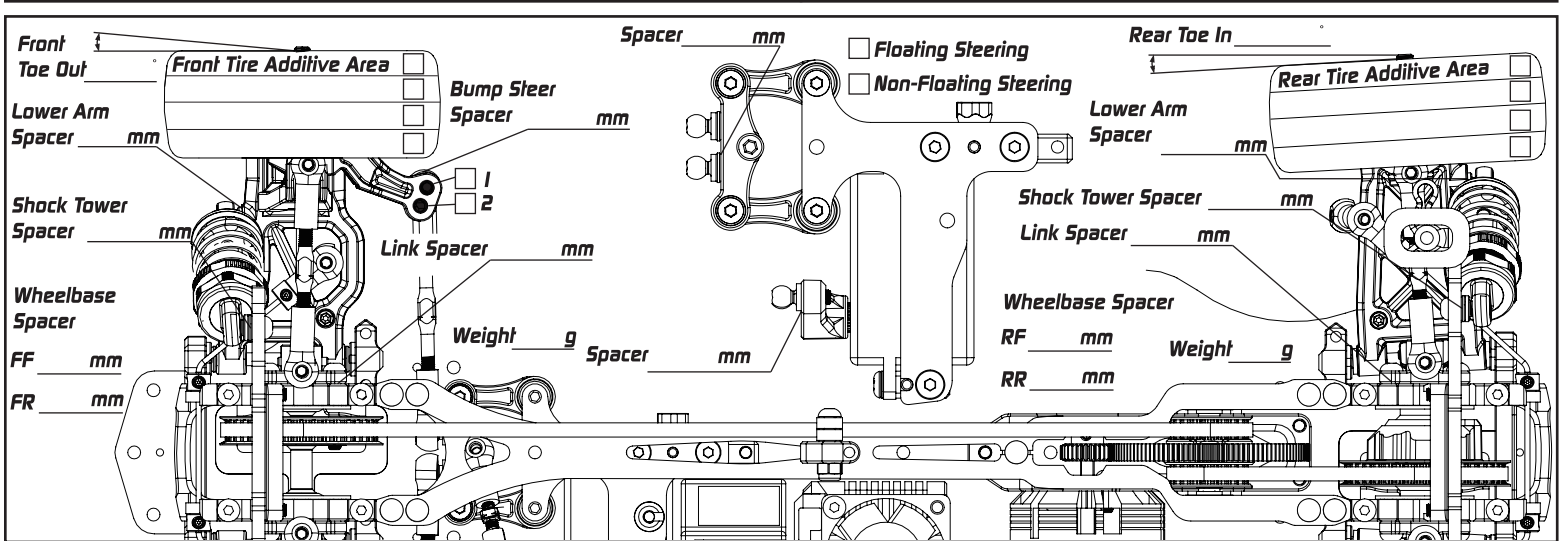
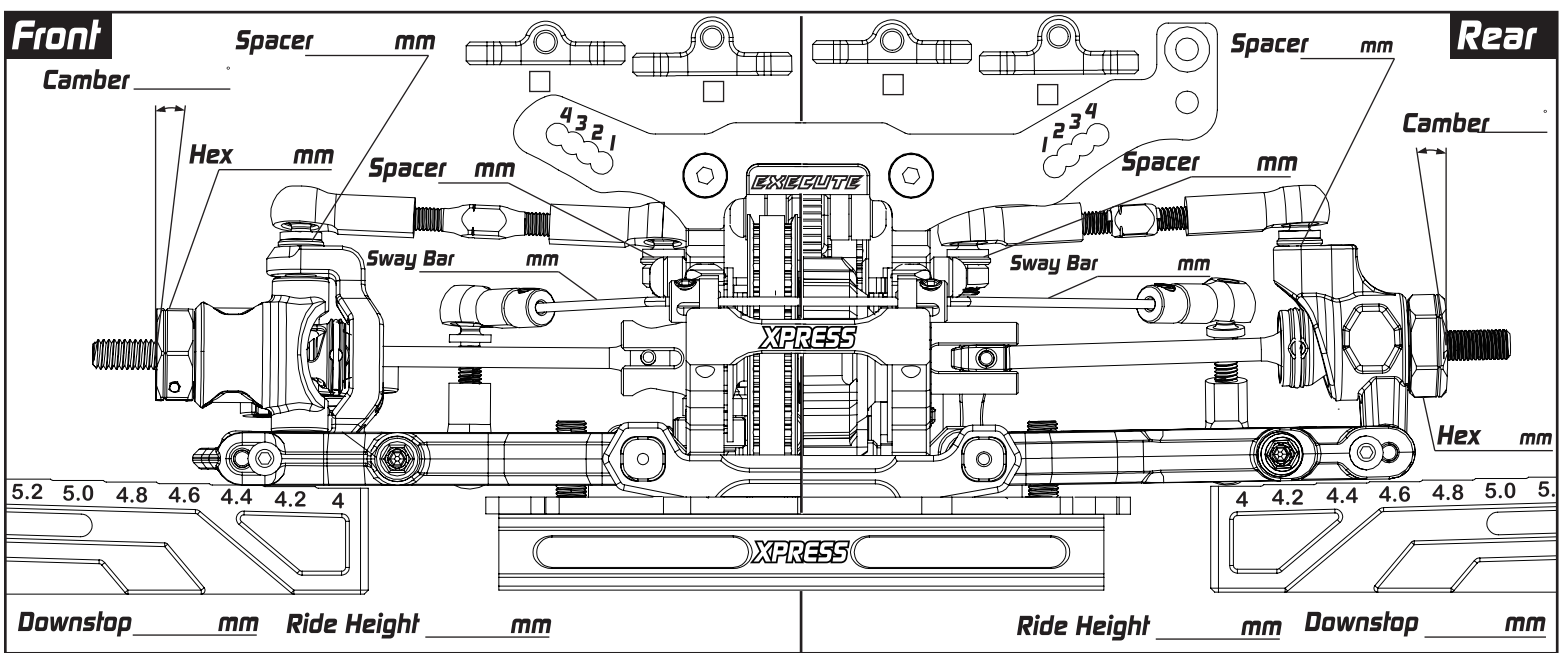

Damper Setup

	Front	Rear
Spring	_____	_____
Oil	_____	_____
Rebound	_____	_____
Piston	_____	_____
Length	_____	_____
Foam Insert	<input type="checkbox"/>	<input type="checkbox"/>
Hole In Cap	<input type="checkbox"/>	<input type="checkbox"/>

Transmission Setup

Front	Rear
Oil	_____
Weight	_____ g
Position	_____
Gear Diff	_____
Oil	_____
Weight	_____ g
Position	_____

Others

Servo _____ Tires _____
 Esc _____ Additive _____
 Motor _____ Body _____
 Spur P/ T Rear Wing _____
 Pinon P/ T FDR _____