

STX017

Track Condition

- Composition: Asphalt Carpet
 Surface: Smooth Medium Bumpy
 Traction: Low Medium High
 Size: Tight Medium Open
 Track Temp.: _____ Air Temp.: _____

Electronics

- Motor: _____ Timing: _____
 ESC: _____ Battery: _____
 Spur: _____ Pinion: _____ Final Ratio: _____

Aerodynamics

- Body: _____ Wing: _____

Front Shocks Rear

- Spring - _____
 - Oil - _____
 - Piston - _____
 - Rebound (%) - _____

Anti-Roll Bar

Tires

- Inserts - _____
 - Rims - _____
 - Additive - _____
 - Additive Time - _____



Transmission

- Gear Ball - Differential - Gear Ball
 - Oil - _____
 - Oil Weight (Grs) - _____
 - Setting - _____
 Spool

Roll Center

- Setting - _____

Front-Front

- (2.5 2) 0° (2 2.5)
 (3 1.5) 0.5° (1.5 3)
 Alu Brass

Rear-Rear

- (1 3.5) (3.5 1)
 (5 1.5) (3 1.5)
 (2 2.5) (2.5 2)
 (2.5 2) (2 2.5)
 (3 1.5) (1.5 3)
 (3.5 1) (1 3.5)
 Alu Brass

Front-Rear & Rear-Front

- (2.5 2) Standard Position (2 2.5)
 FR: Alu Brass
 RF: Alu Brass

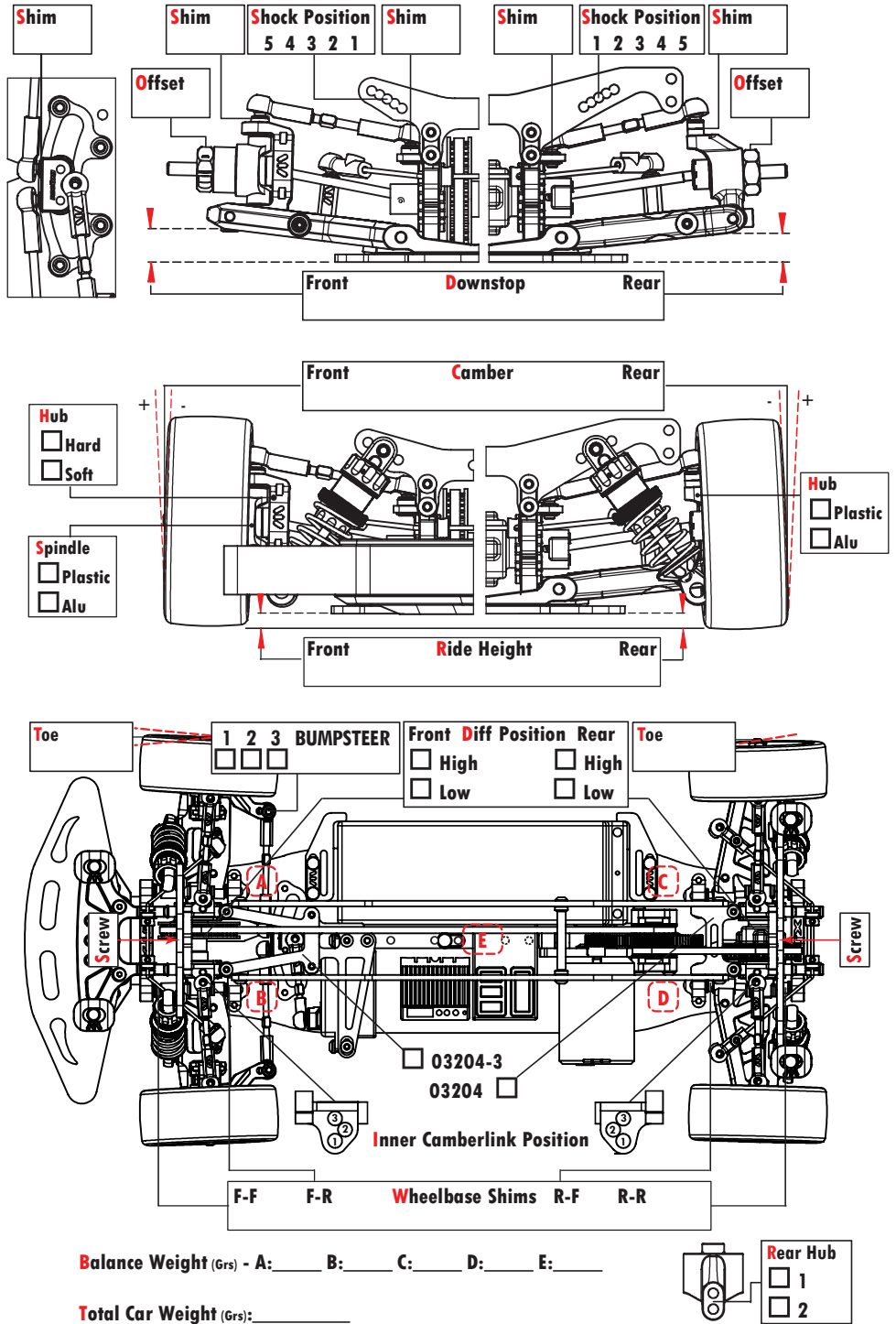

Notes