

Name:
 Date:
 Event:
 Track:
 Track Condition
 Composition:
 Surface:
 Traction:
 Layout:

Transmission
 Front:
 Rear:

Shocks
 Front | Rear

Spring:
 Oil:
 Piston
 Hole:
 Diameter:
 Preload:
 Length:
 Rebound:

Anti-Roll Bar
 Front: 1.3mm 1.4mm 1.5mm
 Rear: 1.1mm 1.2mm 1.3mm

Electronics
 Motor:
 Pinion: Spur:
 Pitch: Ratio:
 ESC:
 Battery:

Body:
 Wing:

Tires:
 Inserts:
 Wheels:
 Treatment:

Comments

STX GET UP SHEET

Roll Center
 +1.0mm
 +0.5mm
 0.0mm
 -0.5mm
 -1.0mm

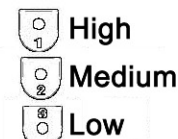

Roll Center
 +1.0mm
 +0.5mm
 0.0mm
 -0.5mm
 -1.0mm

Ride Height

Ride Height

Toe:

FF: RF:
 FR: RR:

Inboard Toe

Inboard Toe

2.0mm = 2.0°
 2.5mm = 2.5°
 3.0mm = 3.0°

2.0mm = 2.0°
 2.5mm = 2.5°
 3.0mm = 3.0°

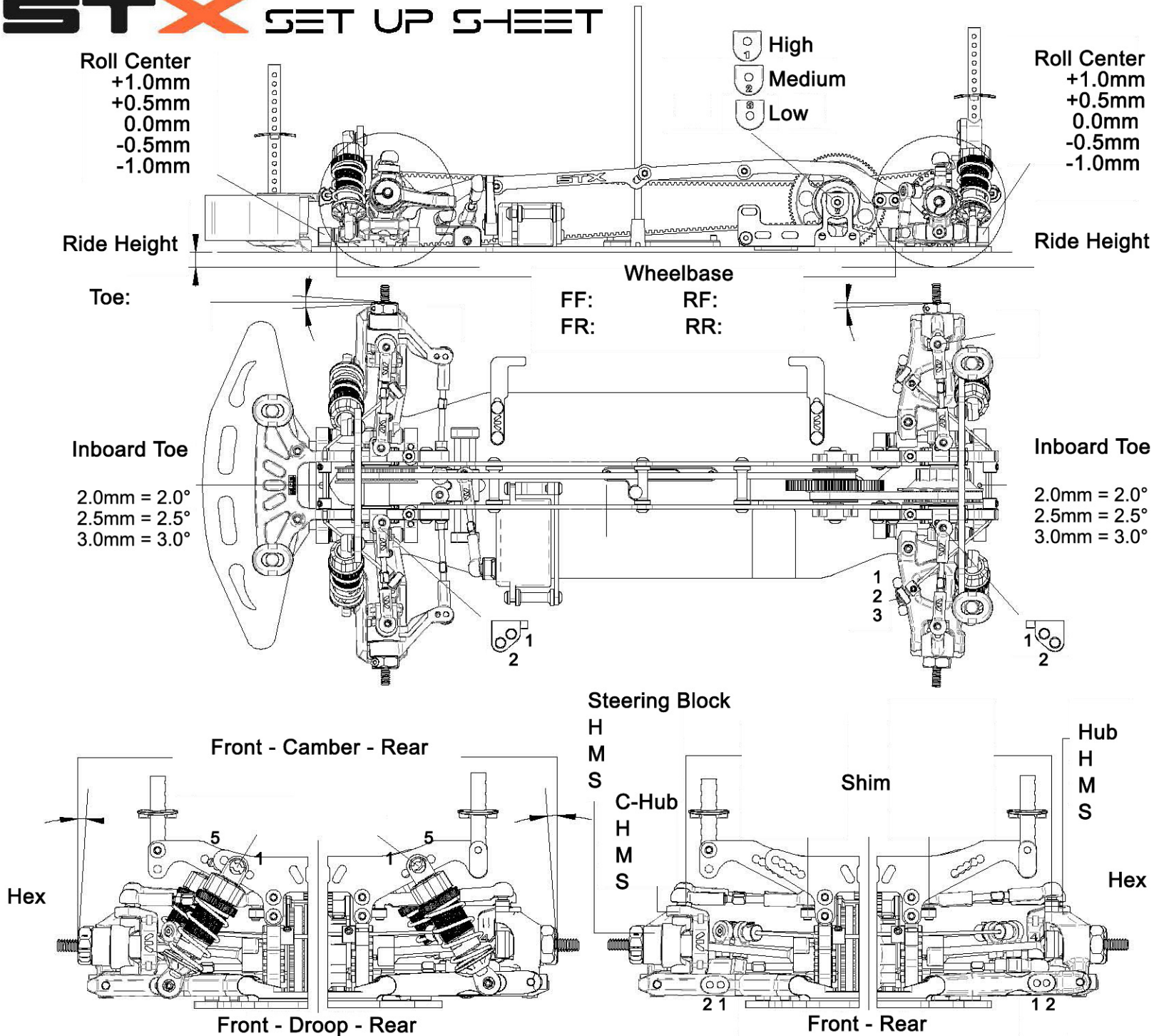

Front - Camber - Rear

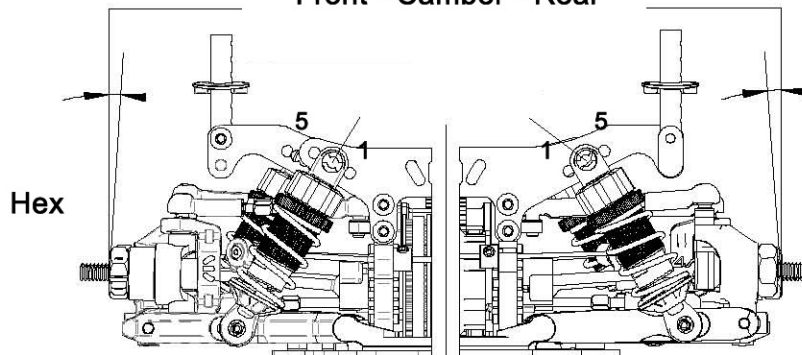

Front - Droop - Rear

Steering Block

H
M
S

C-Hub

H
M
S

Shim

Hub
H
M
S

Hex

2 1

Front - Rear

1 2