

Driver: _____ Event: _____

Date: _____ Track: _____

Track Condition

Composition: Asphalt Carpet
 Surface: Smooth Medium Bumpy
 Traction: Low Medium High
 Size: Tight Medium Open
 Track Temp.: _____ Air Temp.: _____

Electronics

Motor: _____ Timing: _____
 ESC: _____ Battery: _____
 Spur: _____ Pinion: _____ Final Ratio: _____

Aerodynamics

Body: _____ Wing: _____

Front	Shocks	Rear
_____	- Spring - _____	_____
_____	- Oil - _____	_____
_____	- Piston - _____	_____
_____	- Rebound (%) - _____	_____

Anti-Roll Bar

Tires

- Inserts - _____
 - Rims - _____
 - Additive - _____
 - Additive Time - _____



Transmission

Gear Ball - Differential - Gear Ball
 - Oil - _____
 - Oil Weight (Grs) - _____
 - Settings - _____
 Spool

Roll Center

Front-Front	Rear-Rear
(2.5 2) <input type="checkbox"/> 0° <input type="checkbox"/> (2 5/2) (3 1.5) <input type="checkbox"/> 0.5° <input type="checkbox"/> (3 1.5)	(1 3.5) <input type="checkbox"/> <input type="checkbox"/> (2.5 2) (5 1.5) <input type="checkbox"/> <input type="checkbox"/> (3 1.5) (2 2.5) <input type="checkbox"/> <input type="checkbox"/> (3.5 1)
Front-Rear & Rear-Front	
(2.5 2) <input type="checkbox"/> Standard Position <input type="checkbox"/> (2 2.5)	(2.5 2) <input type="checkbox"/> <input type="checkbox"/> (3.5 1) <input type="checkbox"/> (3 1.5) <input type="checkbox"/> (3 1.5) <input type="checkbox"/> (3.5 1) <input type="checkbox"/> <input type="checkbox"/> (2.5 2) <input type="checkbox"/> (2.5 2) <input type="checkbox"/>

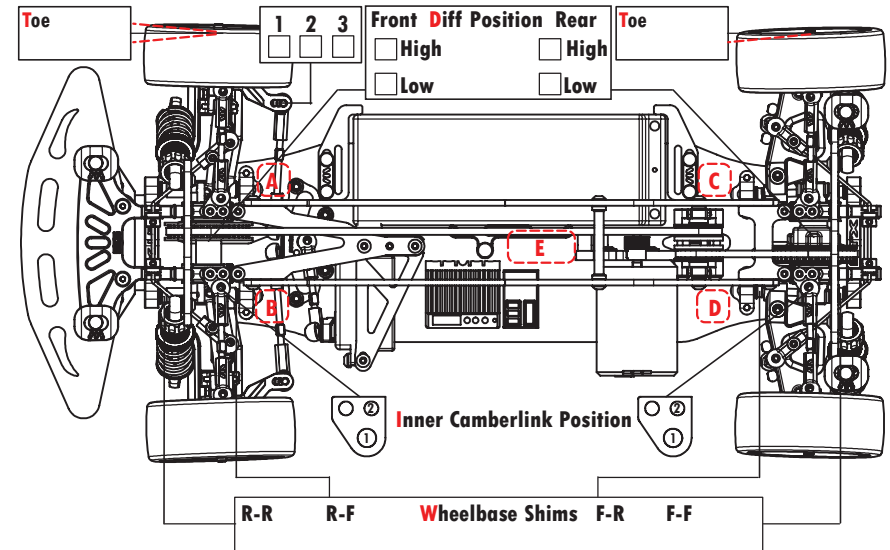
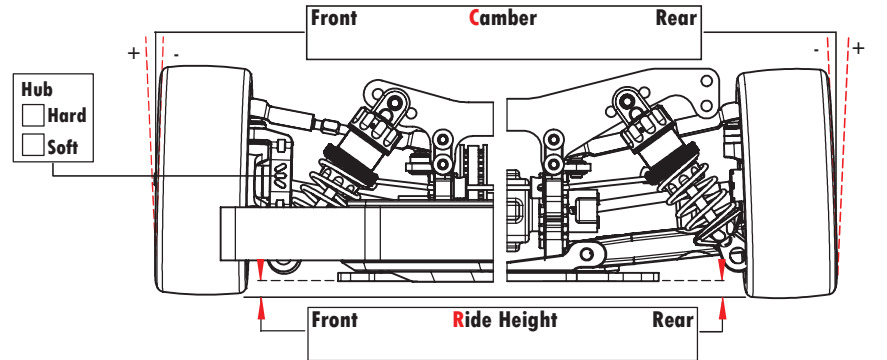
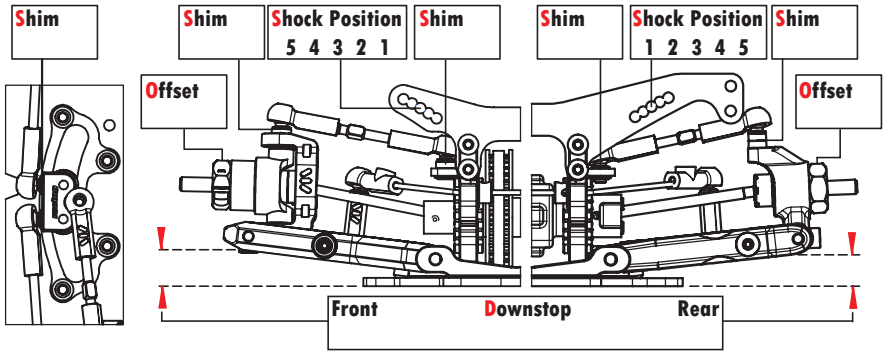

Balance Weight (Grs) - A: _____ B: _____ C: _____ D: _____ E: _____
 Total Car Weight (Grs): _____

Comments