

# STX.7

*new generation rc car*

**1/10 SCALE ELECTRIC  
TOURING CAR**

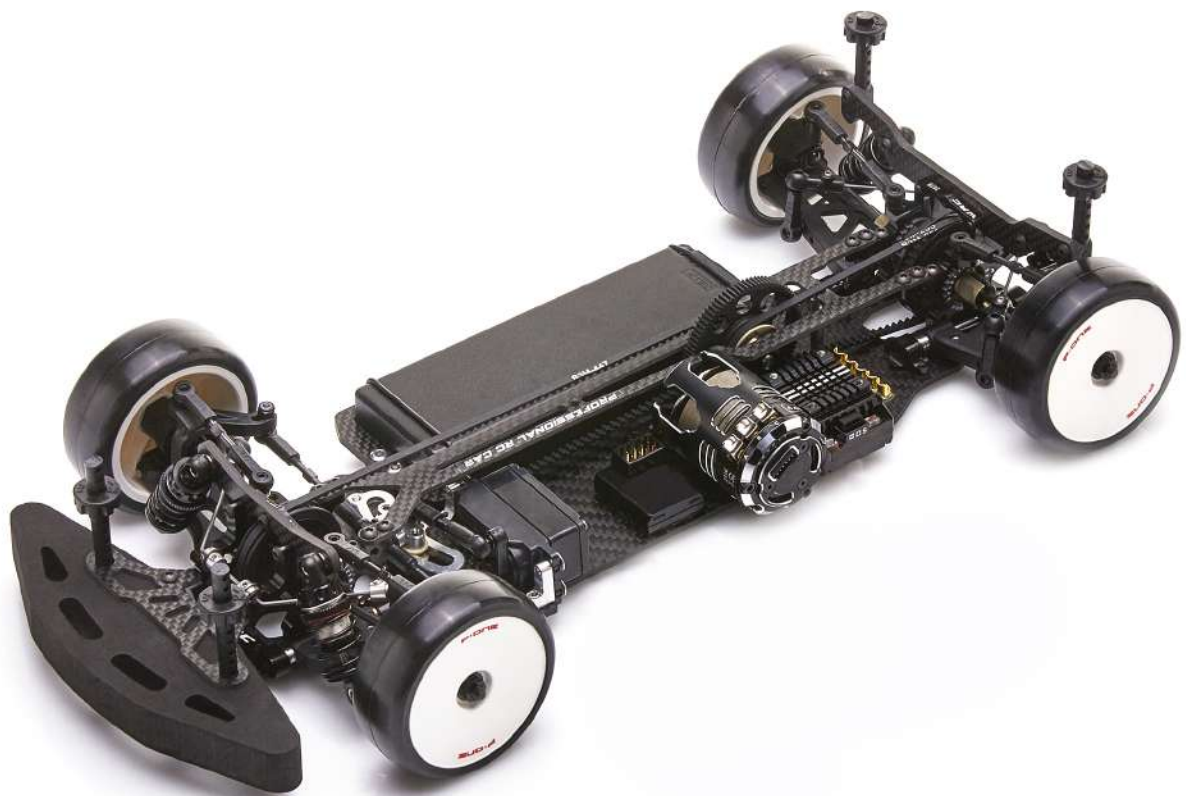

**INSTRUCTION MANUAL**

**WRC**  
*PROFESSIONAL RC CAR*

[www.wrc-racing.com](http://www.wrc-racing.com)



## INTRODUCTION

STX is a new generation high quality 1/10 scale touring car.  
STX is supplied in a box equipped with Instruction Manual.  
Its use is intended for more than 16 years old persons with experience on rc model car field.  
Children and all the persons without this requirement MUST have direct supervision of a knowledgeable adult responsible.

## SAFETY PRECAUTIONS

Instruction Manual MUST be read and fully understood before to start building and operating functions.  
Always keep Instruction Manual in safety place, ready to be consulted for any reference you need.  
Use only original WRC spare parts.

## GENERAL INFORMATION

Assemble the kit only away from the reach of children.  
Follow the building and operating instructions using the utmost care.  
Don't put any part of your body inside rotating and moving elements as this may cause damage or serious injury.  
Check and clean the model before putting it away.  
Don't use your model car in public places or in roads and areas where it could generate conflict with person or vehicular traffic.  
The model car is controlled by radio: you MUST put great care to avoid loss of radio control always keeping a safety margin all around your model in order to prevent any collision.  
Operating frequency: check and be sure it is clear and not shared with anybody at same time; it could cause loss of control of the RC model.  
Always turn on your transmitter before you turn on the receiver in the car and always turn off the receiver before you turn off your transmitter.  
Keep the wheels of the model off the ground when checking the operation of the radio equipment.  
Disconnect the battery pack before storing your model.

## WARRANTY

WRC guarantees this model kit to be free from defects in both material and workmanship within 30 days of purchase.  
The total monetary value under warranty will in no case exceed the cost of the original kit purchased.  
This warranty doesn't cover any components damaged by use or modification or as result of wear.  
Part or parts missing from this kit must be reported within 30 days of purchase.  
No part or parts will be sent under warranty without proof of purchase.  
If you find a defective or missing part, contact the local distributor.  
Customer service and support will be provided through local hobby store.  
No warranties are expressed or implied that cover damage caused by what is considered normal use or cover or imply how long any model cars' components or electric components will last before requiring replacement.  
Due to the high performance level of this model car you will need to periodically maintain and replace consumable components; any and all warranty coverage will not cover replacement of any part or component damaged by neglect, abuse or improper or unreasonable use.  
This includes but is not limited to damage from crashing, excessive moisture, improper use or no maintenance or user modifications which compromise the integrity of components.  
Warranty will not cover components that are considered consumable on RC model car.  
WRC doesn't pay nor refund on any component sent from WRC or its distributor for warranty.  
WRC reserves the right to make final determination of the warranty status of any component or part  
Use only original WRC spare part:

## CUSTOMER SUPPORT

Please don't hesitate to contact WRC support at [info@wrc-racing.com](mailto:info@wrc-racing.com) for any problem or question.  
Also kindly visit our website [www.wrc-racing.com](http://www.wrc-racing.com) to find last updates, set-up information, option parts and other information.

### W.R.C. world racing car s.r.l.

Via Meucci, 23/B  
36040 Brendola (VI)  
ITALY

Phone: 0039 0 444 401138  
fax: 0039 0 444 401139  
E-mail: [info@wrc-racing.com](mailto:info@wrc-racing.com)  
Website: [www.wrc-racing.com](http://www.wrc-racing.com)



**PROFESSIONAL RC CAR**

## TECHNICAL INFORMATION

- TRANSMISSION: 4 DRIVE WHEELS
- BODY: TOURING MODEL (NOT INCLUDED)
- ADJUSTABLE FRONT TOE, CAMBER AND CASTER
- ADJUSTABLE REAR TOE AND CAMBER
- BUMPER /FRONT BACKSTOP
- CARBON CHASSIS
- FULL BALL BEARING
- DIFFERENTIAL GEAR

## TECHNICAL DATA

- LENGHT ..... 373 MM.
- WIDTH .....187 MM.
- ADJUSTABLE WHEEL BASE .....MIN. 250 MM. - MAX 256 MM.
- WEIGHT CHASSIS..... 515 GR.

## REQUIRED BUT NOT INCLUDED IN THE KIT

ADDITIONAL ITEMS NEEDED FOR COMPLETION



LIPO BATTERY 7.4 V.

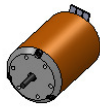

ELECTRIC MOTOR  
PINION GEAR

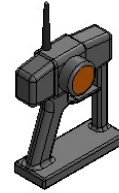

TRANSMITTER



RECEIVER



SPEED CONTROLLER



LOW PROFILE STEERING SERVO



AA ALKALINE BATTERIES  
FOR TRANSMITTER



WHEEL - TYRES - INSERTS

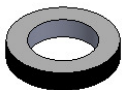

LIPO BATTERY TAPE



LEXAN BODY

## TOOLS REQUIRED

THESE TOOLS ARE NOT INCLUDED IN THE KIT BUT ARE REQUIRED FOR PROPER ASSEMBLY



SOCKET:  
5.5 MM  
7.0 MM



ALLEN :  
1.5 MM  
2.0 MM  
3.0 MM

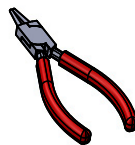

RING PLIERS

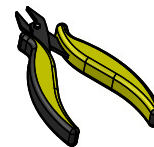

SIDE CUTTER



SCISSORS

## NOTICE:

THE FOLOWING ITEMS ARE NEEDED FOR COMPLETION PF THE STX; THEY ARE NOT INCLUDED IN THIS KIT (UNLESS NOTED) AND SHOULD BE OBTAINED FROM YOUR LOCAL HOBBY SHOP.  
BE SURE TO READ THE INSTRUCTION COMPLETELY PRIOR TO ASSEMBLY

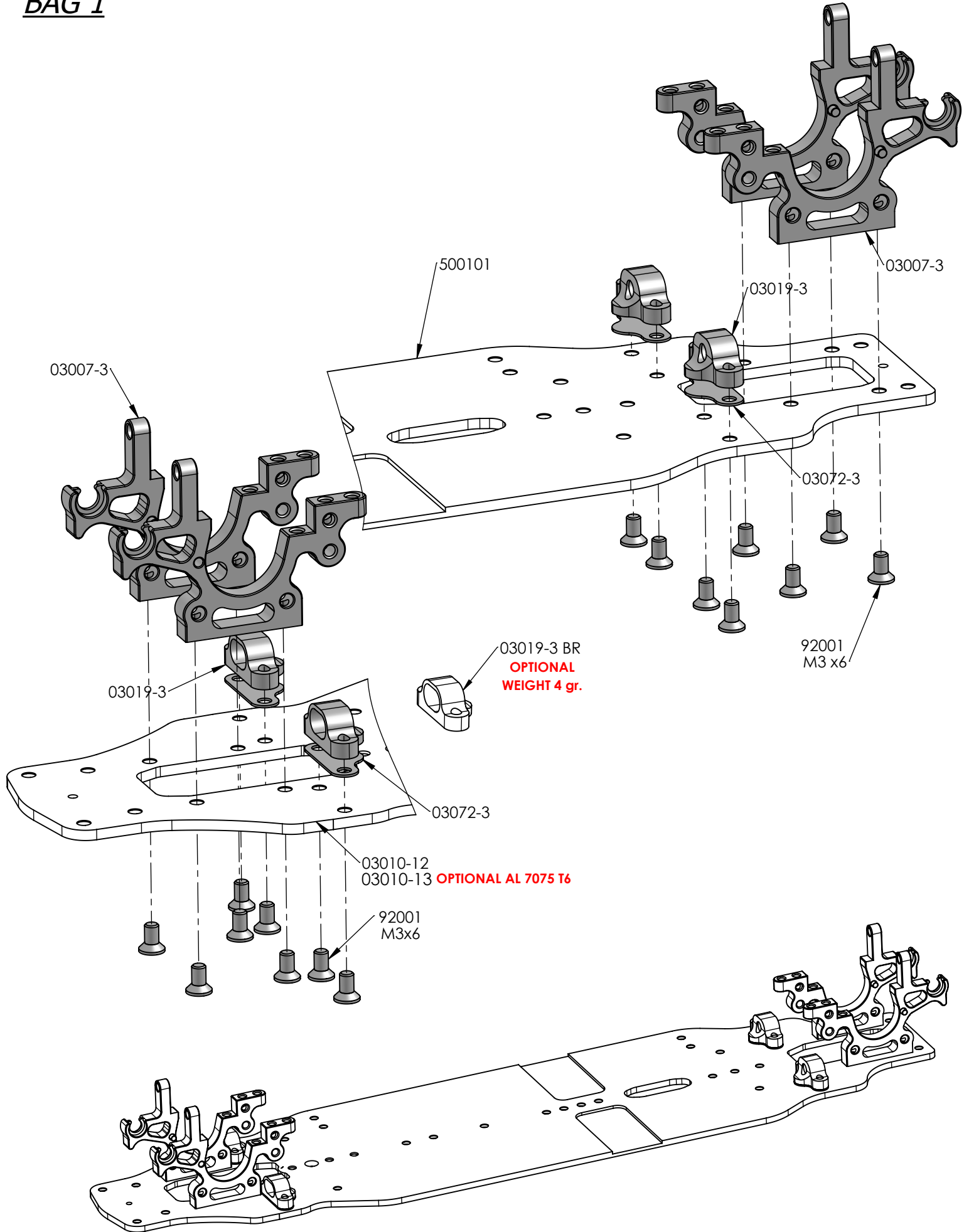

### REAR DIFFERENTIAL GEAR

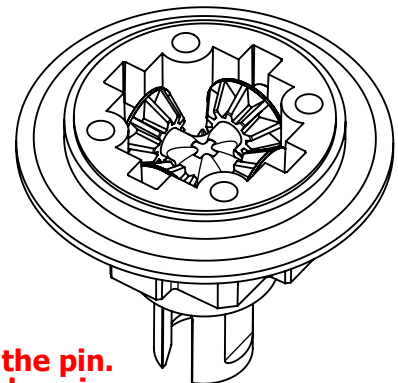
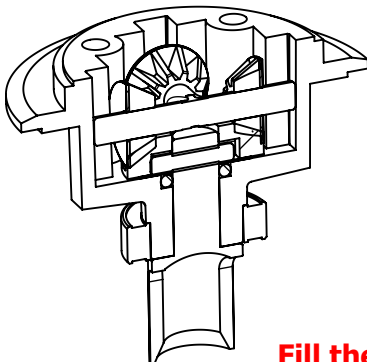
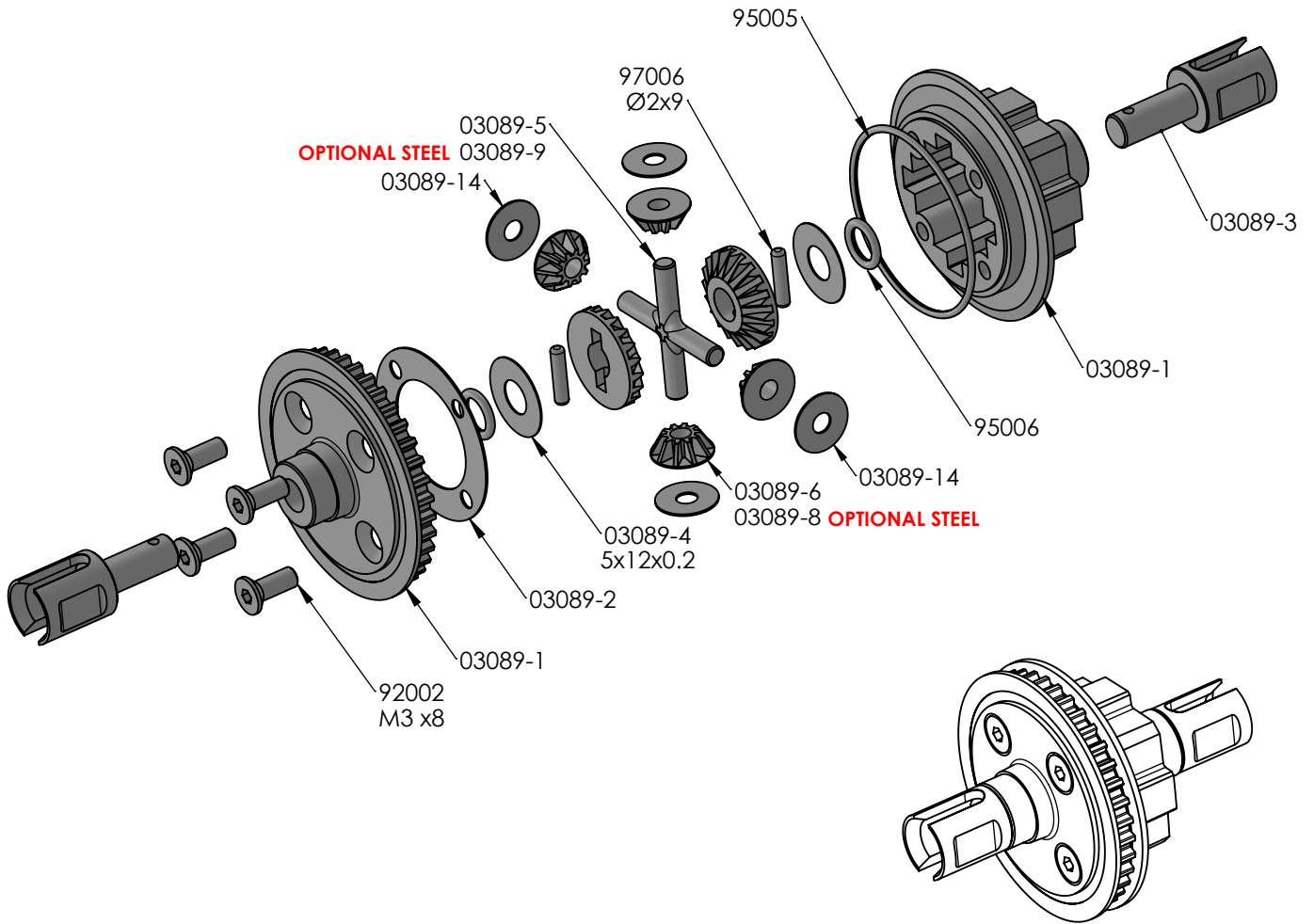

**Fill the differential up to the top of the pin.  
DO NOT fill the diff. to the top of the housing.  
SILICONE OIL 2000**

### CENTRAL TRASMISSION

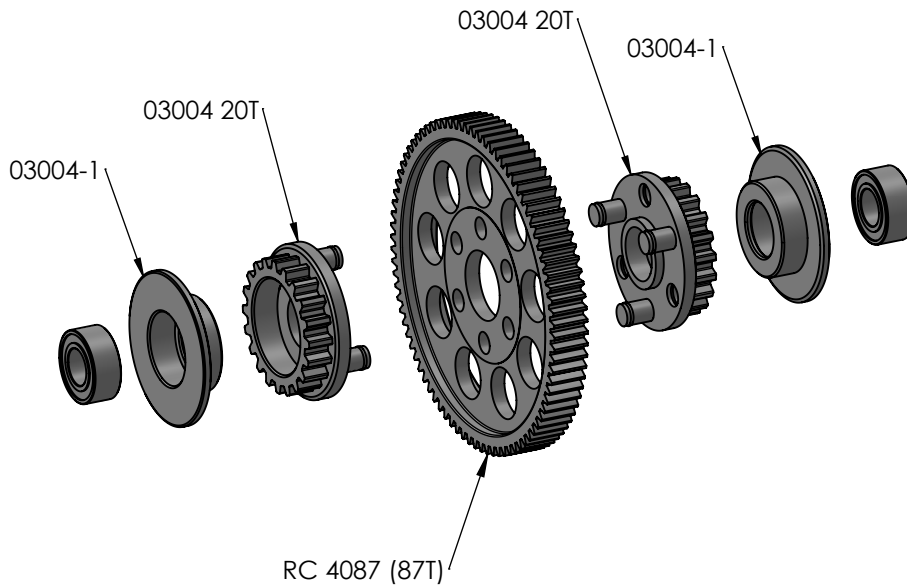

SPUR GEAR P48	
RC4078	78 T
RC4084	84 T
RC4087	87 T
SPUR GEAR P64	
RC6092	92 T
RC6096	96 T
RC60100	100 T
RC60104	104 T
RC60106	106 T
RC60108	108 T
RC60110	110 T
RC60112	112 T
RC60114	114 T
RC60116	116 T
RC60118	118 T

## BAG 4

### SOLID FRONT AXEL

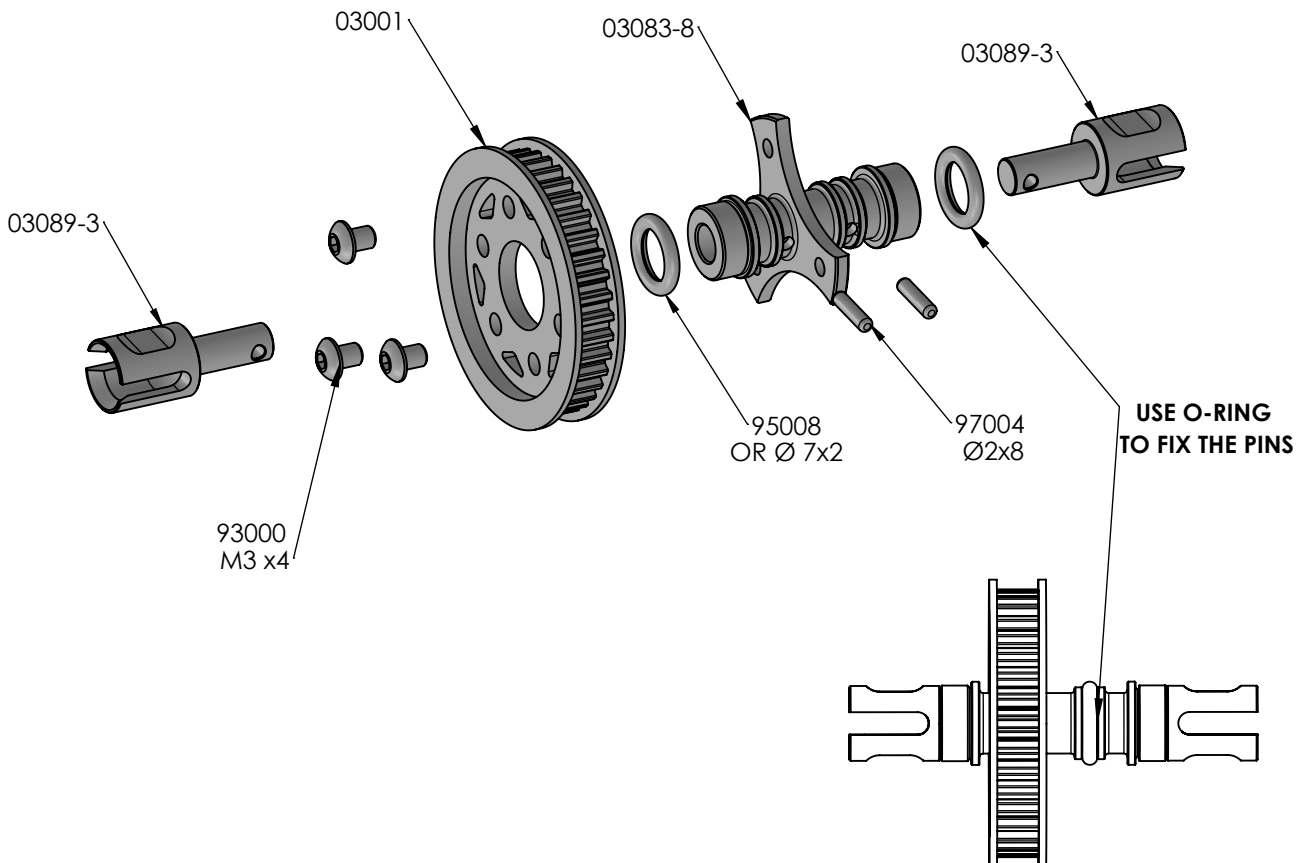

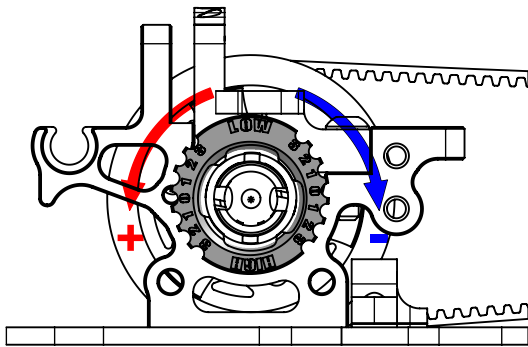
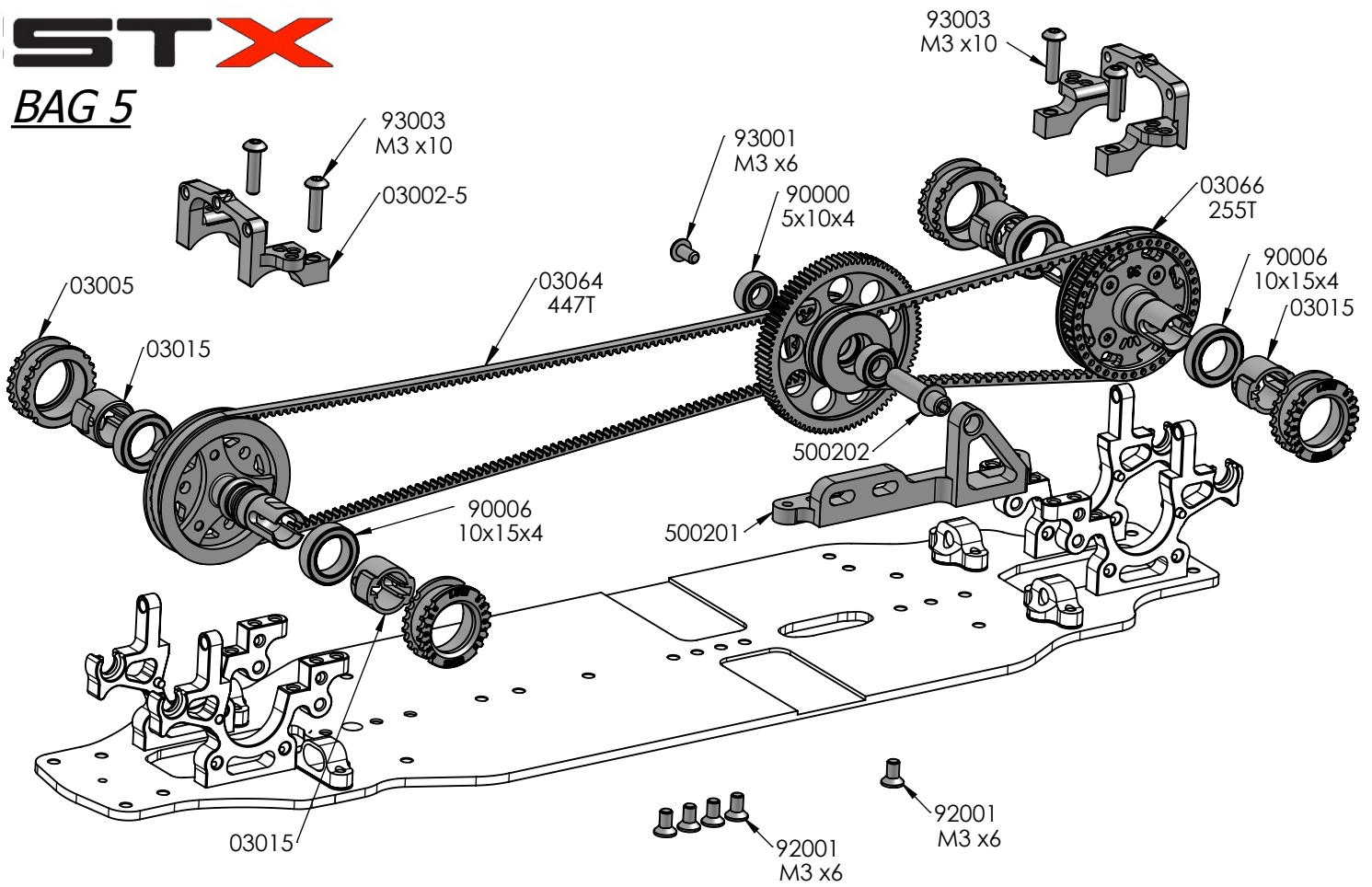

**FRONT BELT ADJUSTMENT**

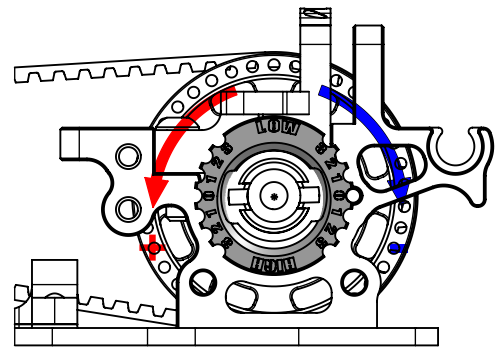

**REAR BELT ADJUSTMENT**

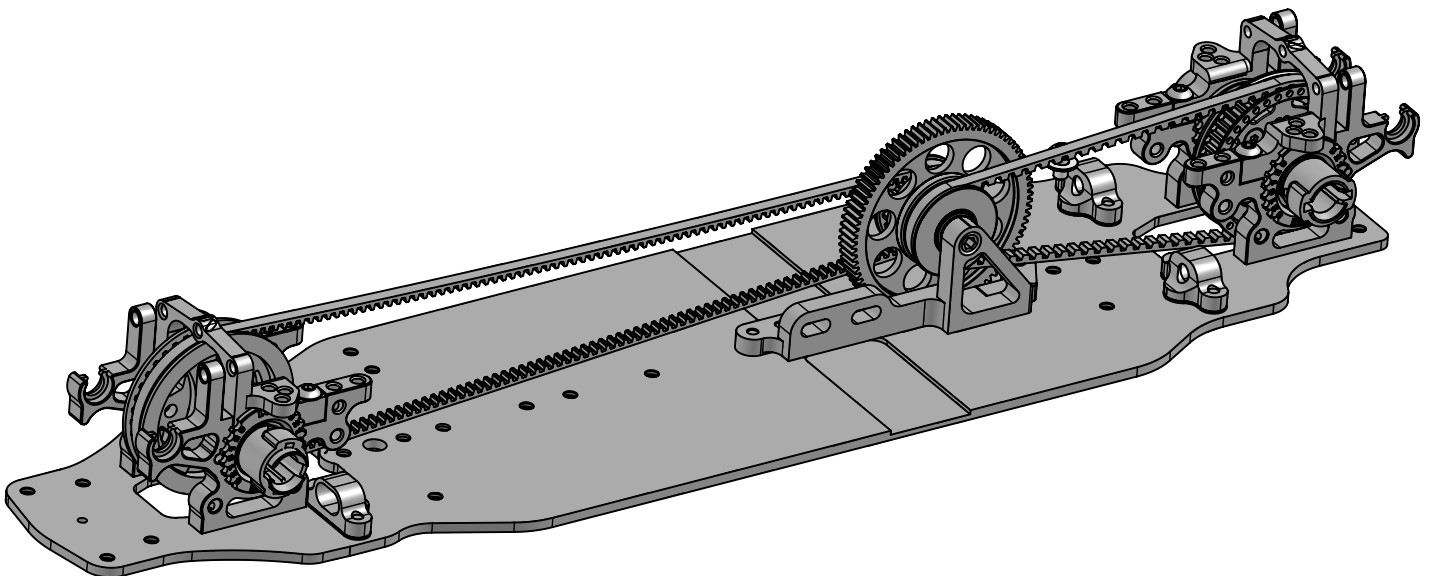

BAG 6

X2

## FRONT

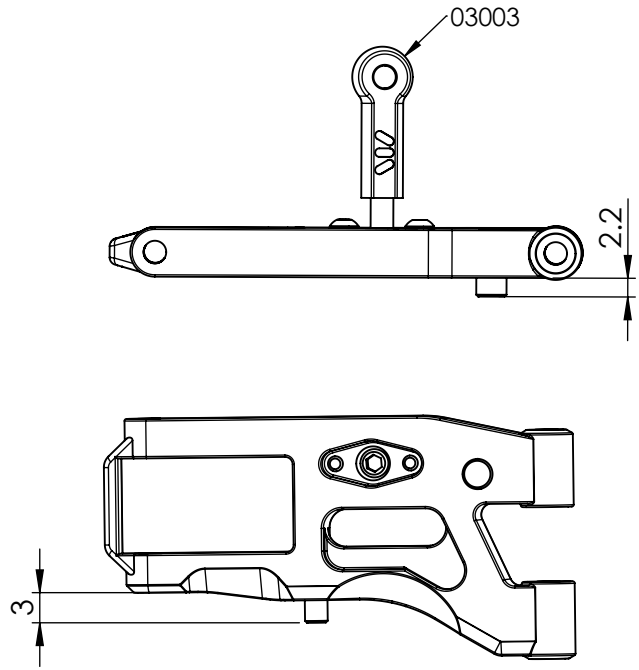
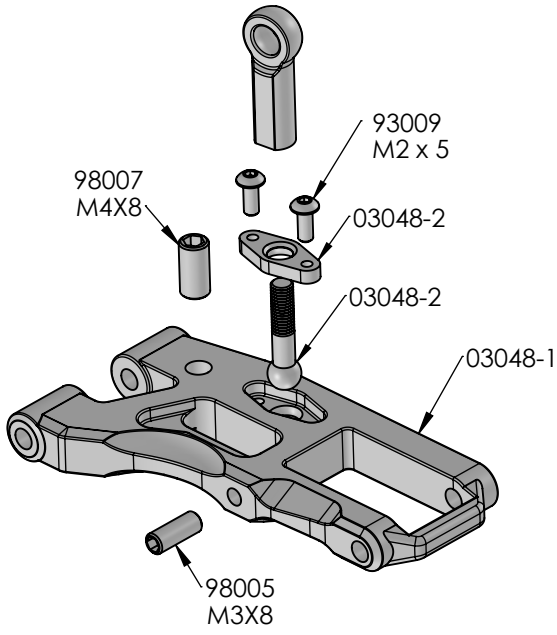

## REAR

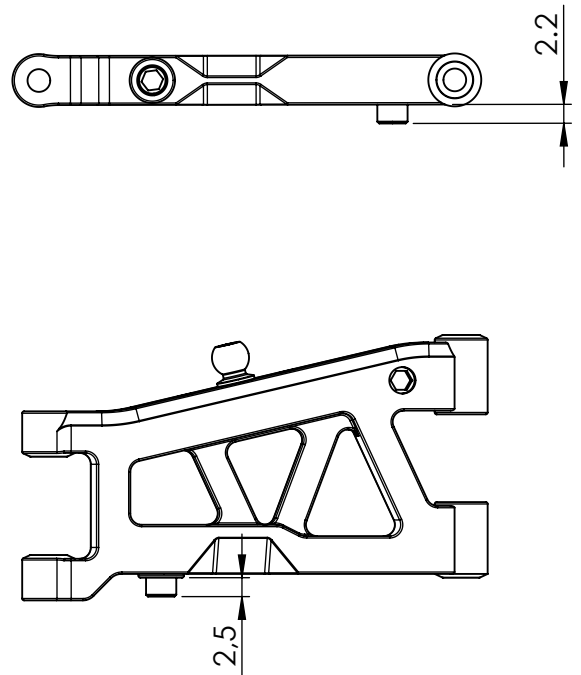
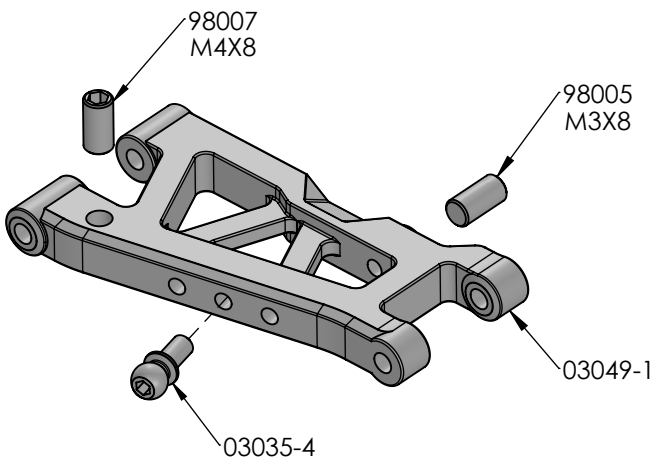



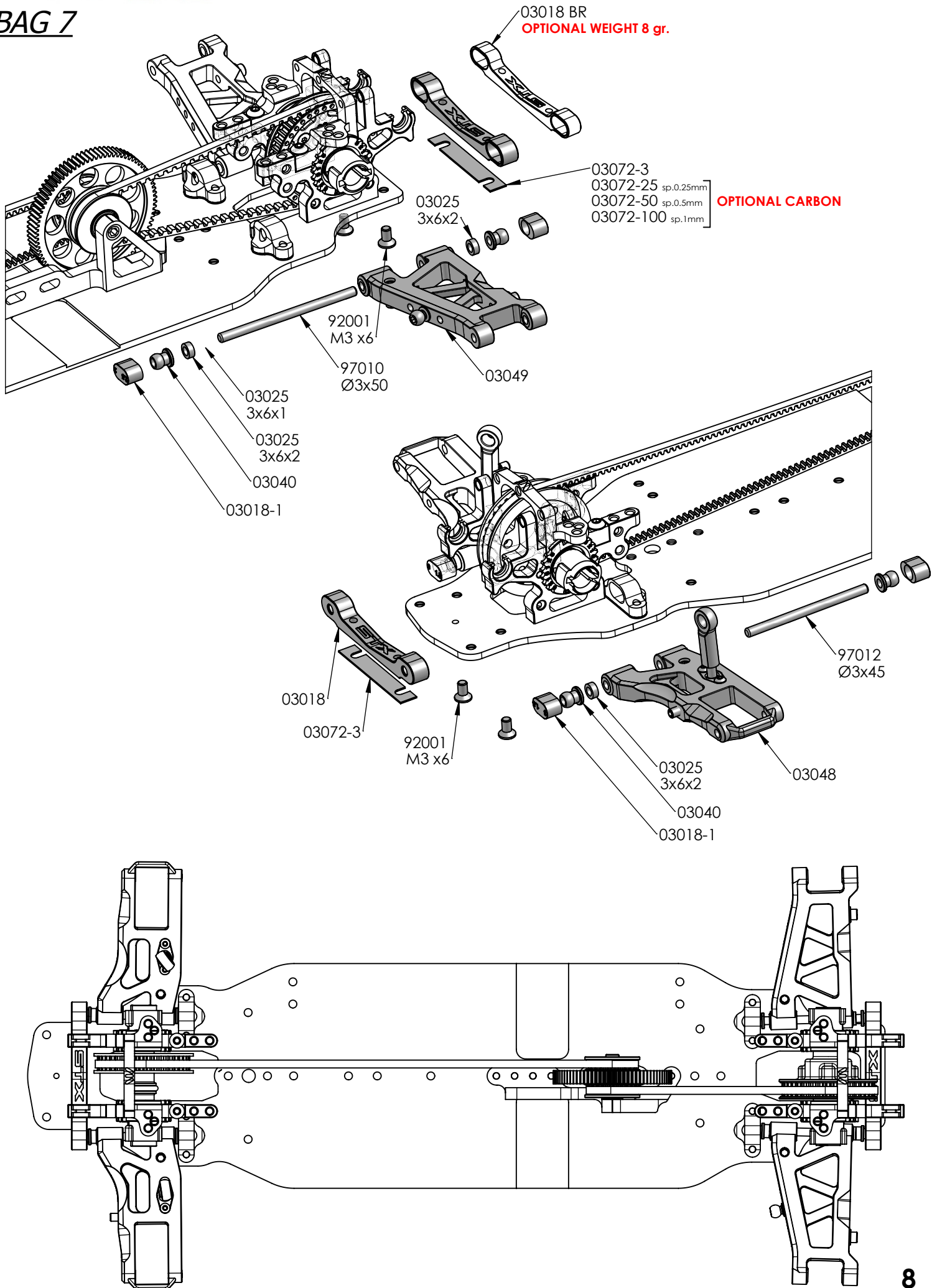

# Arm Angles Diagram - FRONT

STX		FR MOUNT					
FRONT		43,5	44,5	45	46	47	47,5
FF MOUNT		0°	0,5°	1°	1,5°	2°	3°
		- 0,5°	0°	0,5°	1°	1,5°	2°
		- 1°	- 0,5°	0°	0,5°	1°	1,5°
		- 1,5°	- 1°	- 0,5°	0°	0,5°	1°
		- 2°	- 1,5°	- 1°	- 0,5°	0°	0,5°
		- 3°	- 2°	- 1,5°	- 1°	- 0,5°	0°

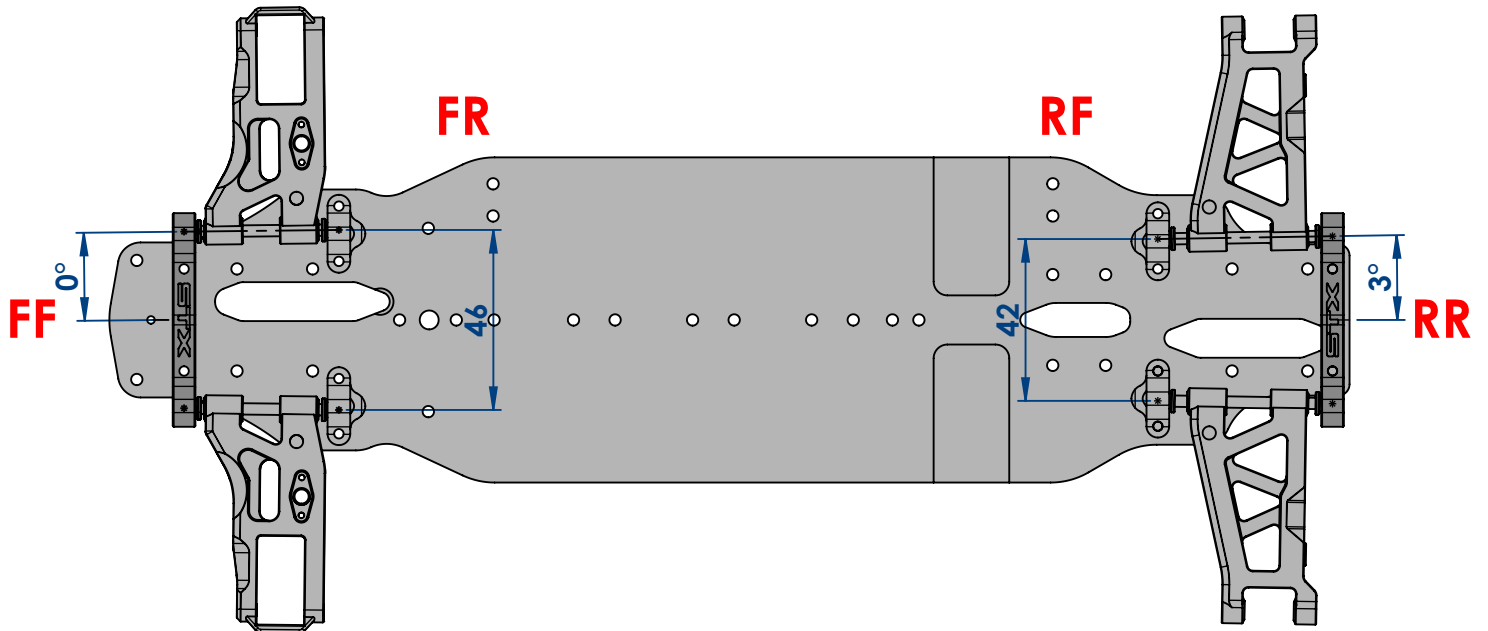
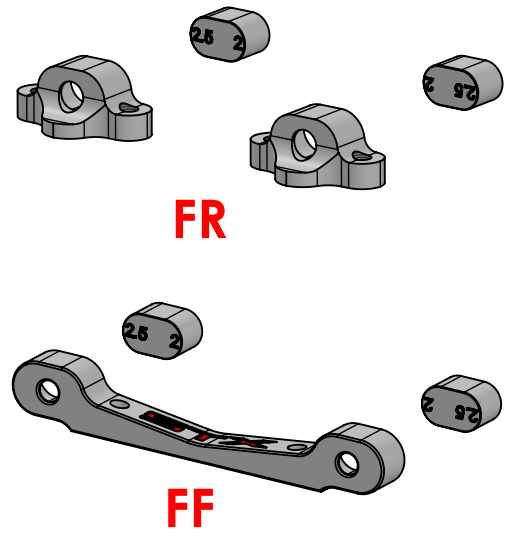

# Arm Angles Diagram - REAR

STX		RF MOUNT					
REAR		39,5	40,5	41	42	43	43,5
RR MOUNT		2,5°	2°	1,5°	1°	0,5°	0°
		3°	2,5°	2°	1,5°	1°	0,5°
		3,5°	3°	2,5°	2°	1,5°	1°
		4°	3,5°	3°	2,5°	2°	1,5°
		4,5°	4°	3,5°	3°	2,5°	2°
		5°	4,5°	4°	3,5°	3°	2,5°

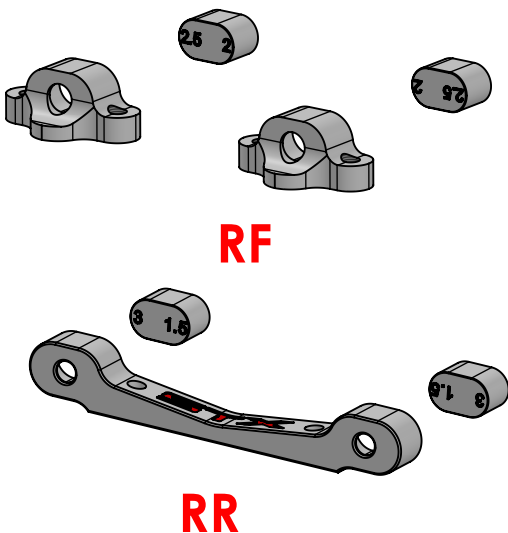

### LEFT - RIGHT FRONT SUSPENSION

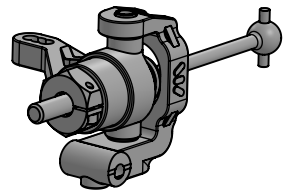
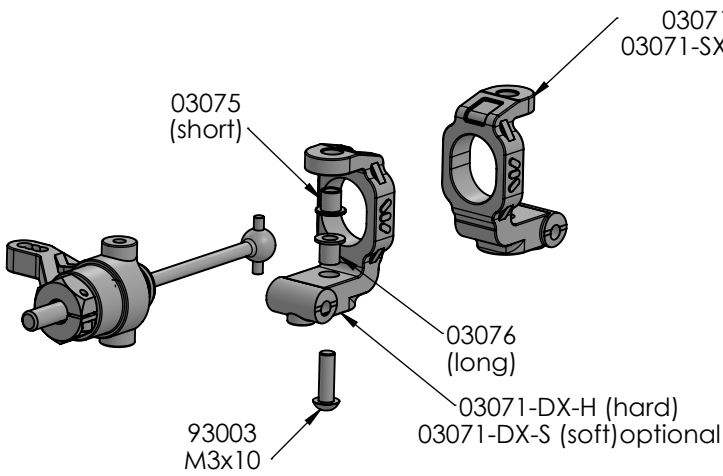
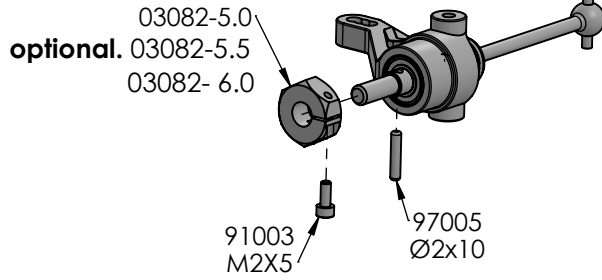
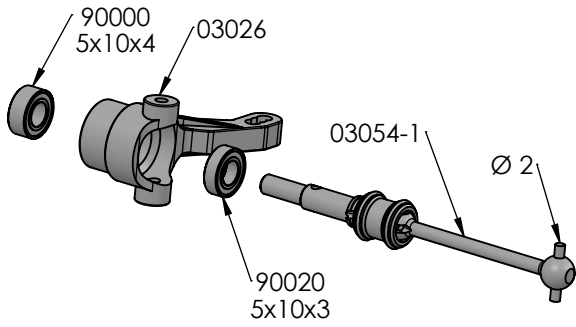

**RIGHT SIDE**

### LEFT - RIGHT REAR SUSPENSION

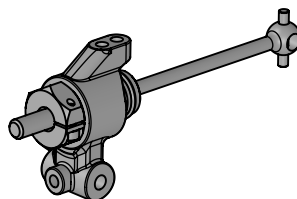
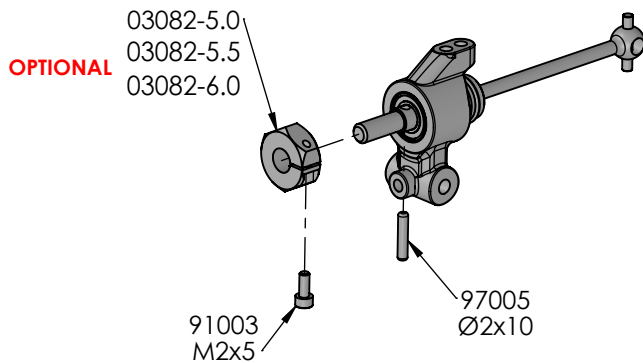
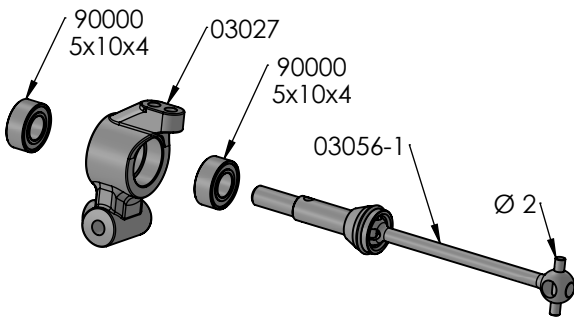

**RIGHT SIDE**

### FRONT

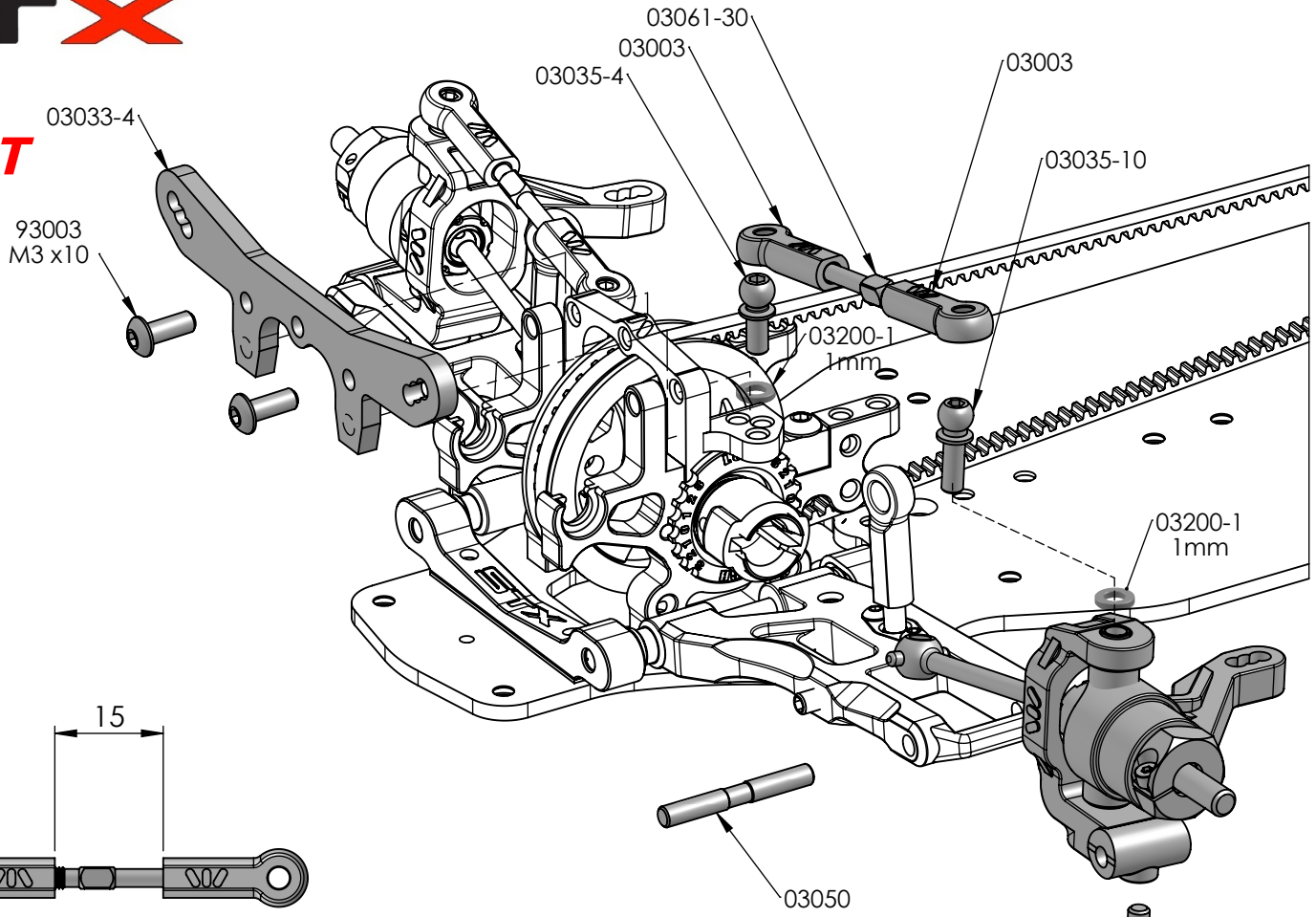

VALID FOR  
FRONT AND REAR

### REAR

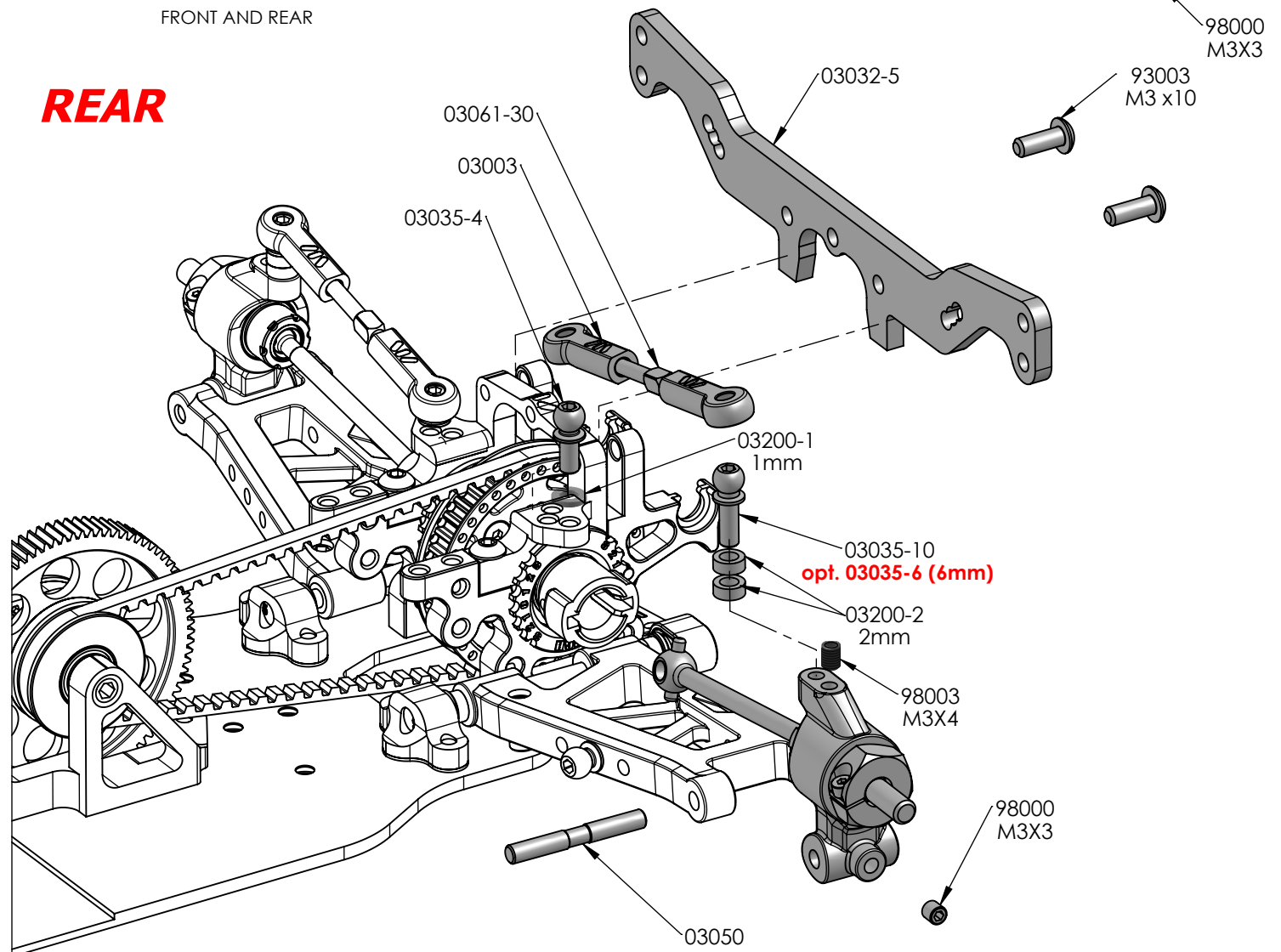

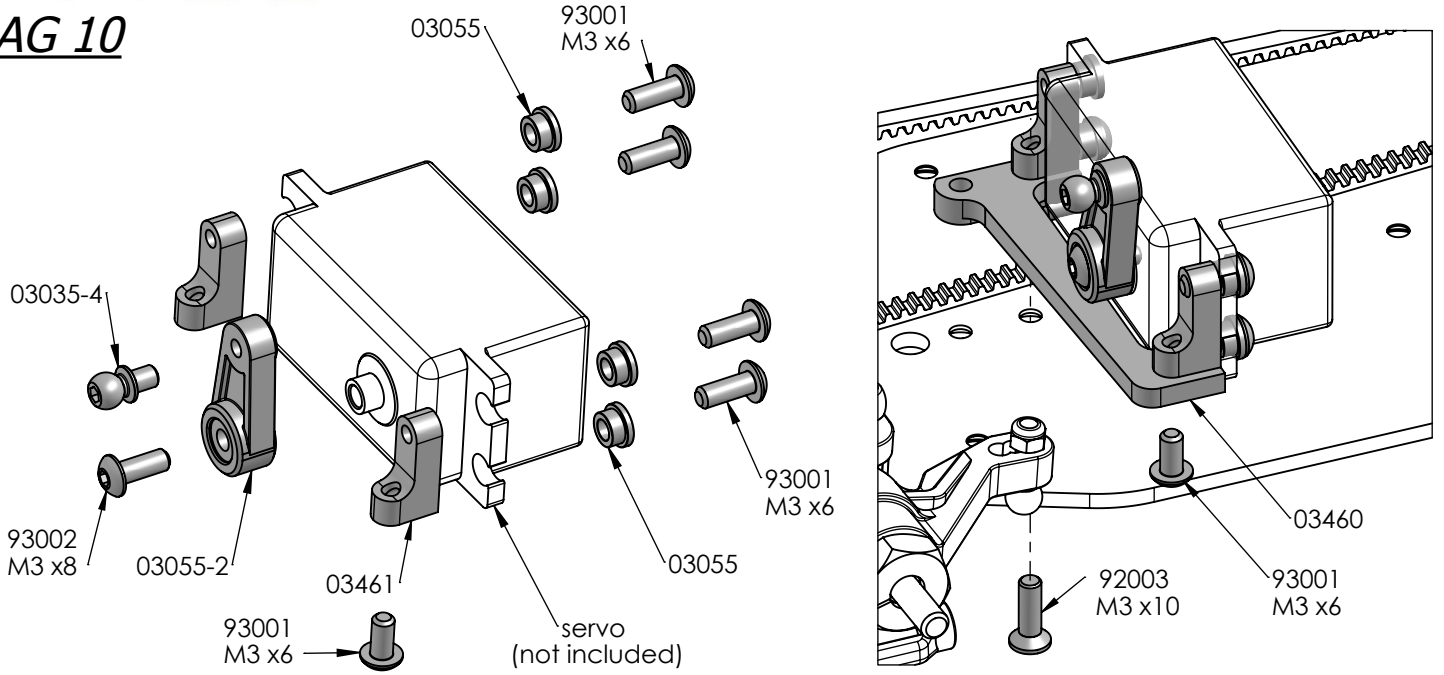

## BAG 11

## DYNAMIC STERRING RAIL

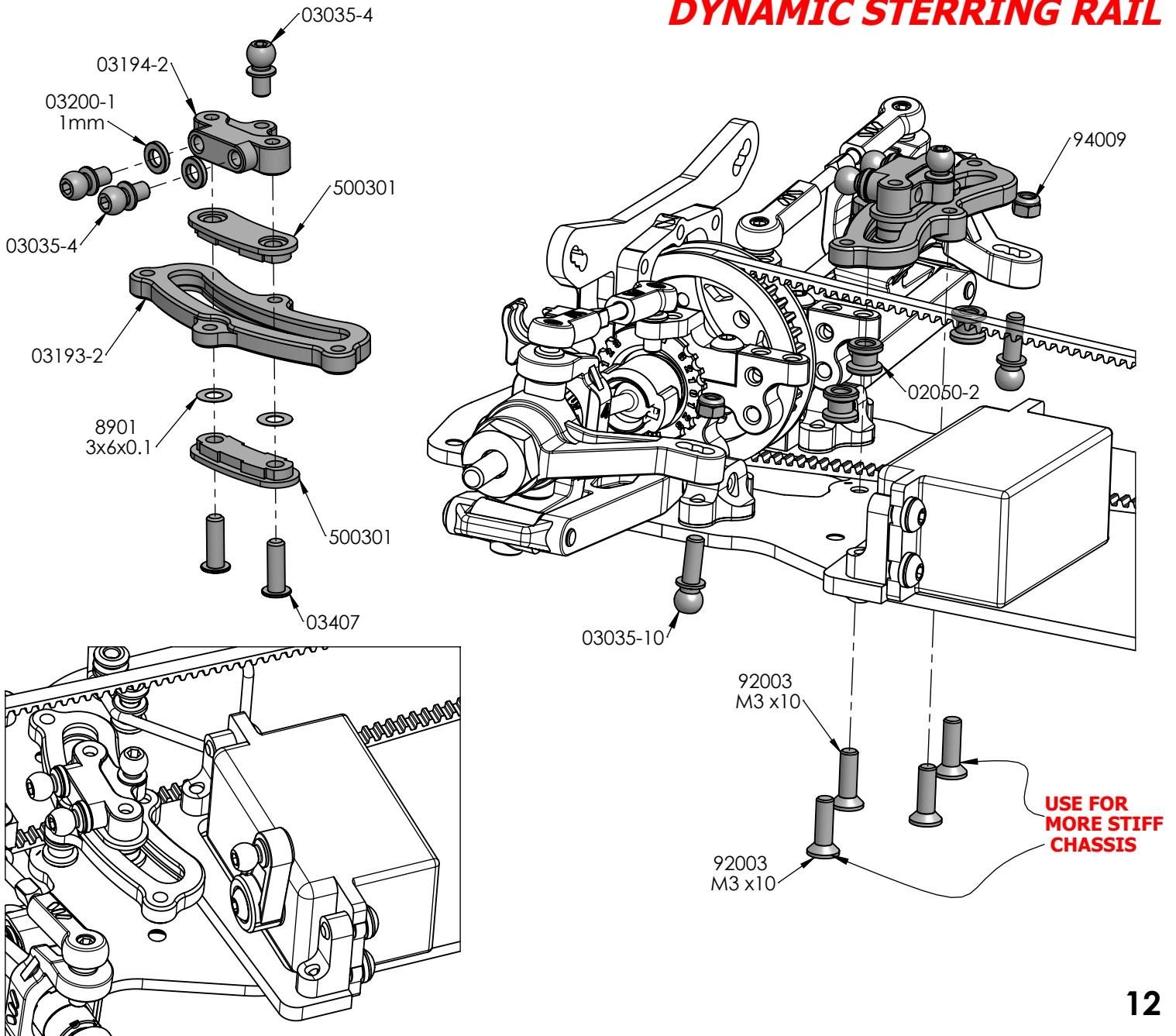



### FRONT ANTI ROLL BAR

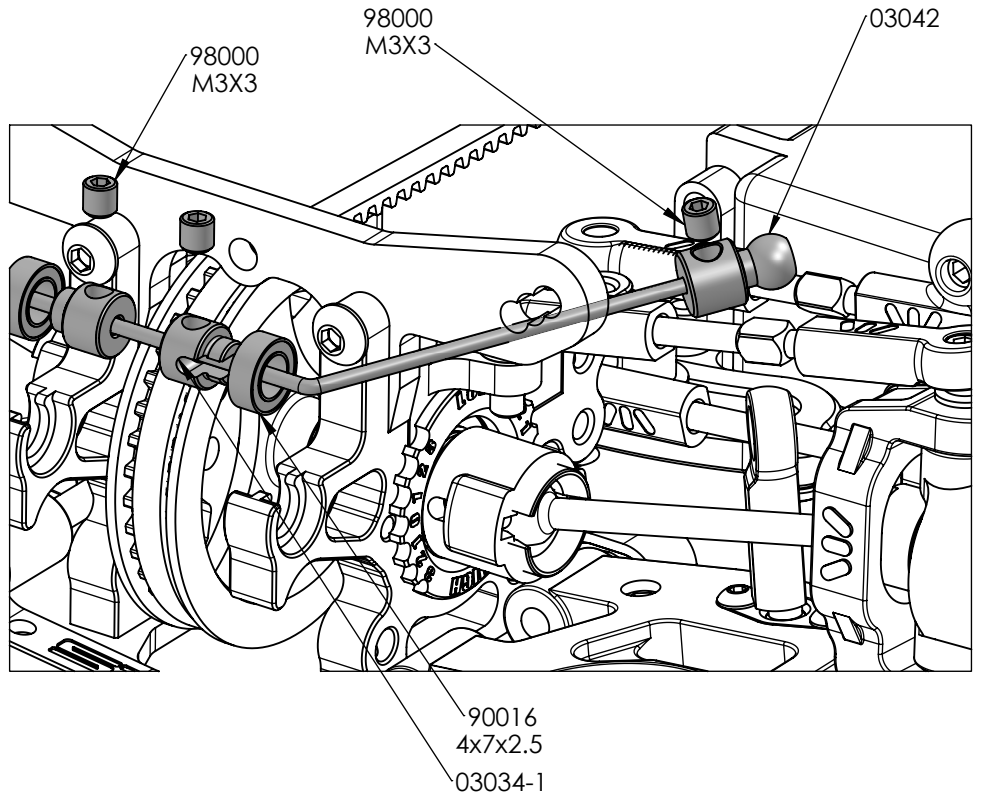

ANTI ROLL BAR		
COD	Ø	
03031-2	Ø 1.2	OPTIONAL
<b>03031-3</b>	<b>Ø 1.3</b>	<b>STANDARD IN KIT</b>
03031-4	Ø 1.4	OPTIONAL
03031-5	Ø 1.5	OPTIONAL
03031-6	Ø 1.6	OPTIONAL

### REAR ANTI ROLL BAR

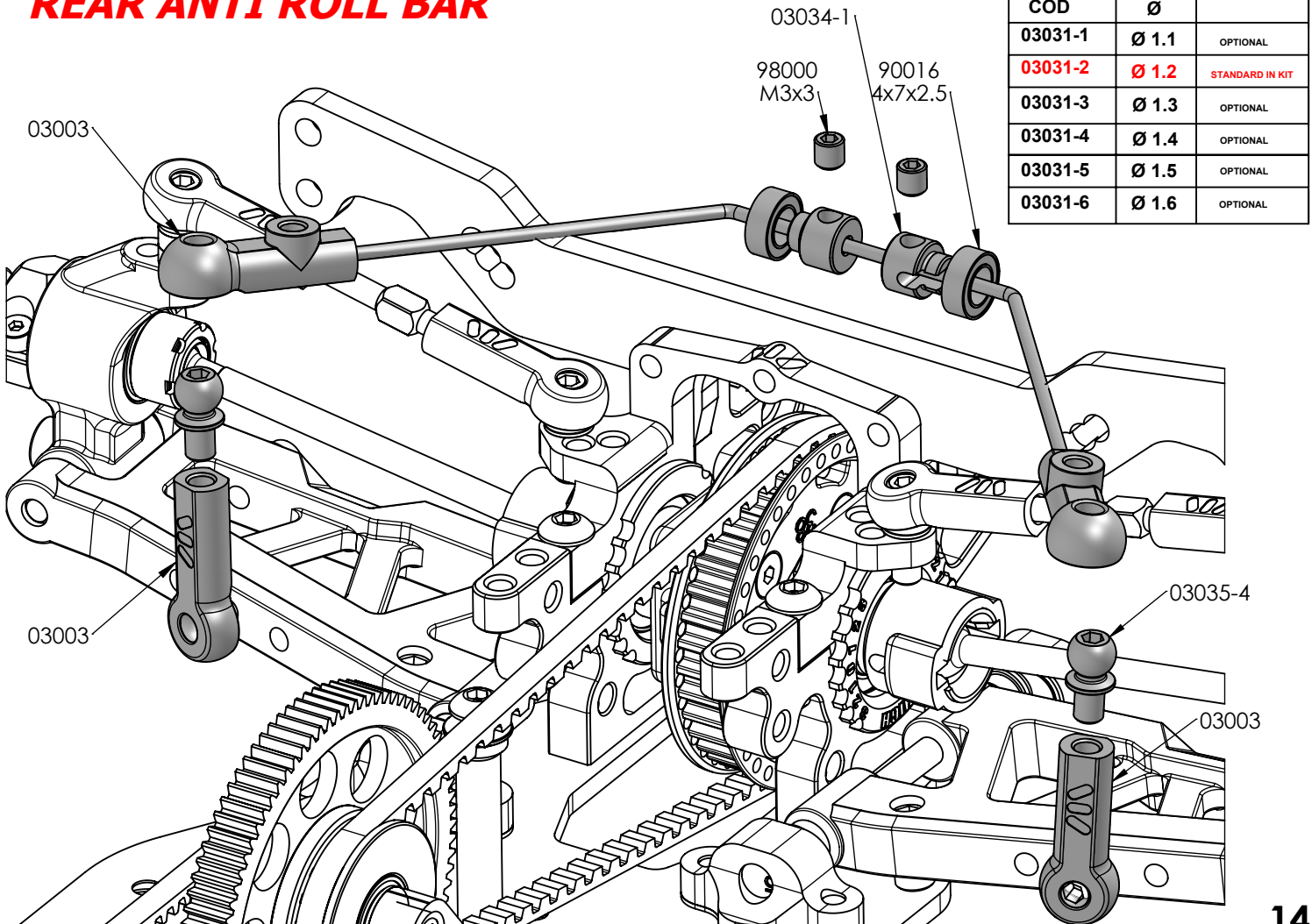

ANTI ROLL BAR		
COD	Ø	
03031-1	Ø 1.1	OPTIONAL
<b>03031-2</b>	<b>Ø 1.2</b>	<b>STANDARD IN KIT</b>
03031-3	Ø 1.3	OPTIONAL
03031-4	Ø 1.4	OPTIONAL
03031-5	Ø 1.5	OPTIONAL
03031-6	Ø 1.6	OPTIONAL

SPRINGS		
COD	Force (lb)	COLOUR
03170-5	2.1	BLACK
03170-6	2.2	YELLOW
03170-7	2.3	RED IN KIT
03170-8	2.6	BLUE
PROGRESSIVE SPRINGS		
03170-9	1.3-2.9	FUCHSIA
03170-10	1.4-3.5	GREEN

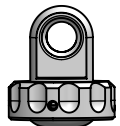
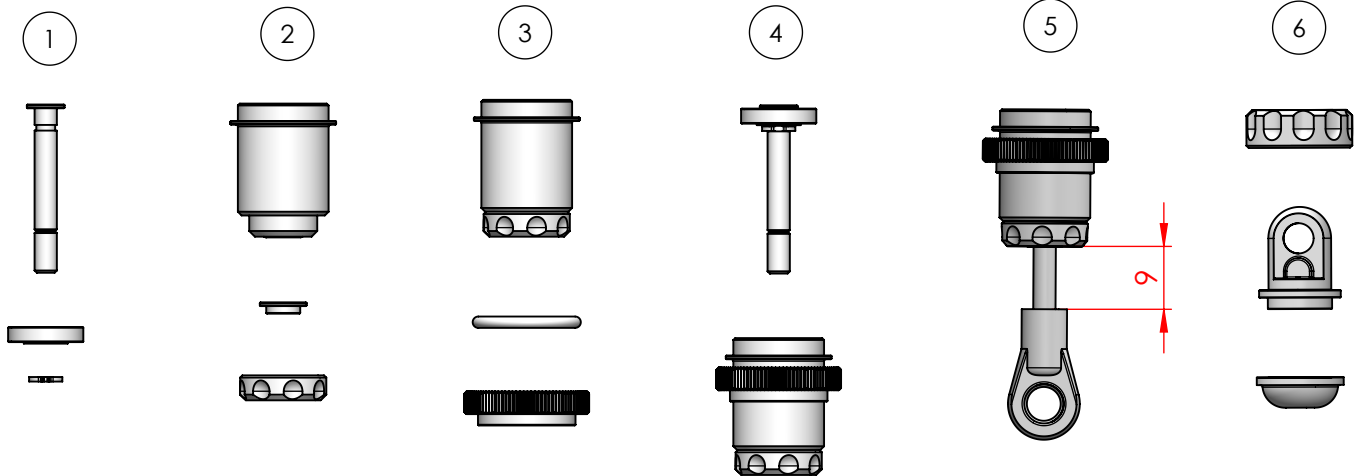
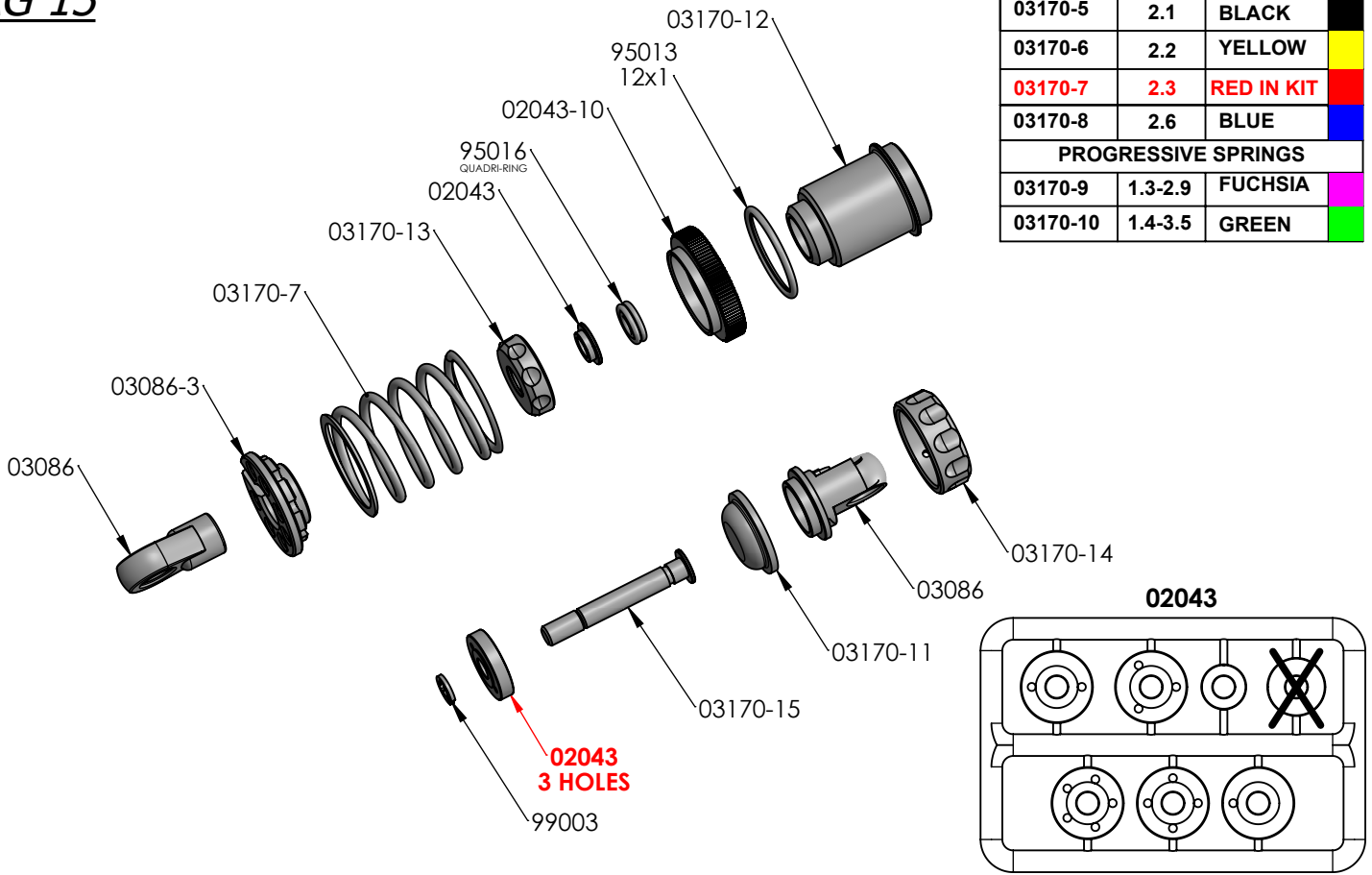

### SHOCK FILLING

Fully extend the piston rod so the piston is at the bottom of the shock body.  
 Hold the shock upright and fill the shock body with shock oil as in the picture.  
 Let the oil settle and allow air bubbles to rise to the top.  
 Slowly move the piston up and down until no more air bubbles appear.  
 Add shock oil as necessary.  
 Pull the piston rod most of the way out of the shock bod.  
 Let the shock rest for 5 minutes to allow the air bubbles to scape.

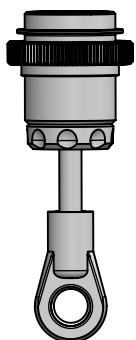

### FRONT - REAR

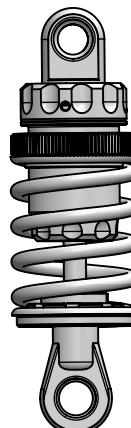

P-ONE SHOCKS OIL	
CODE	CST
SO-350	350
SO-400	400(IN KIT)
SO-450	450
SO-500	500
SO-550	550
SO-600	600
SO-650	650
SO-700	700
SO-800	800



## REAR SHOCKS

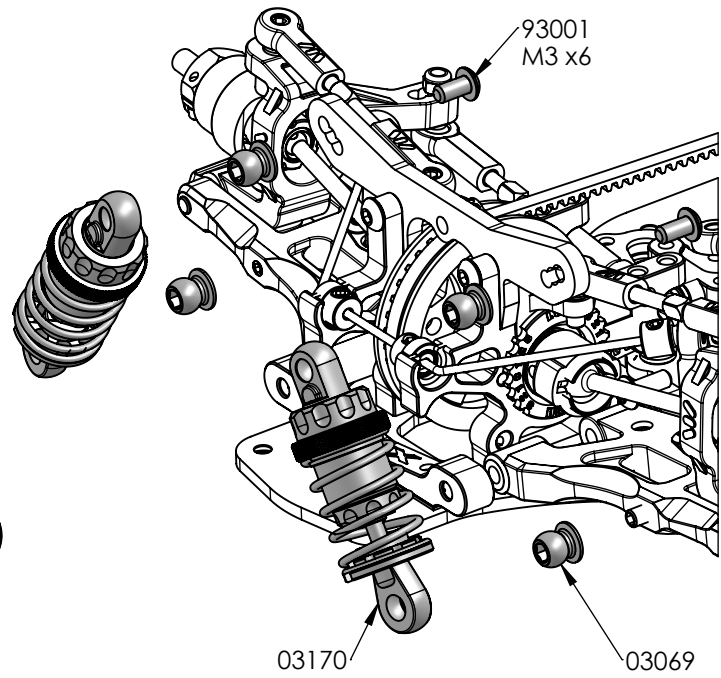
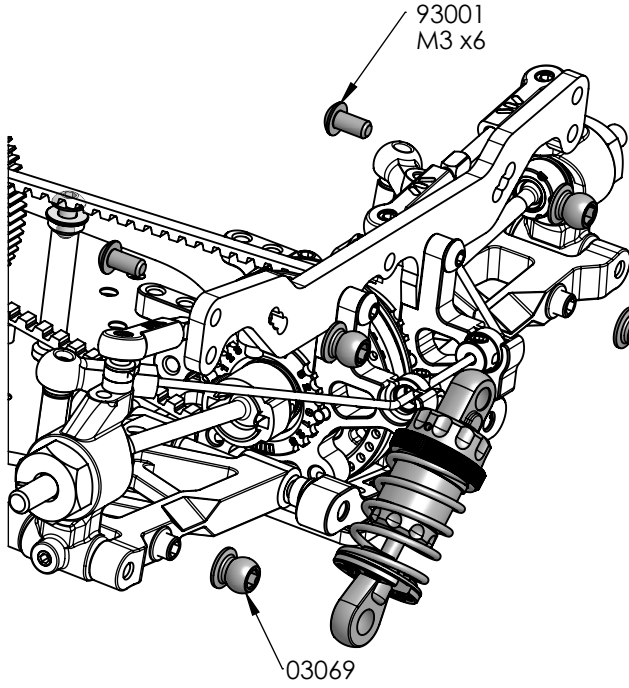

## FRONT SHOCKS

### BAG 14 X2

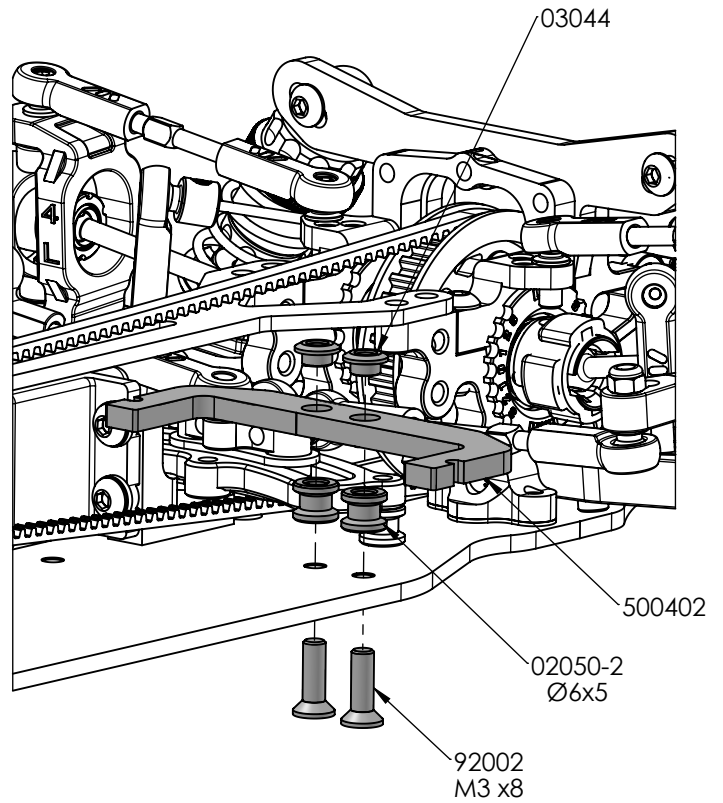
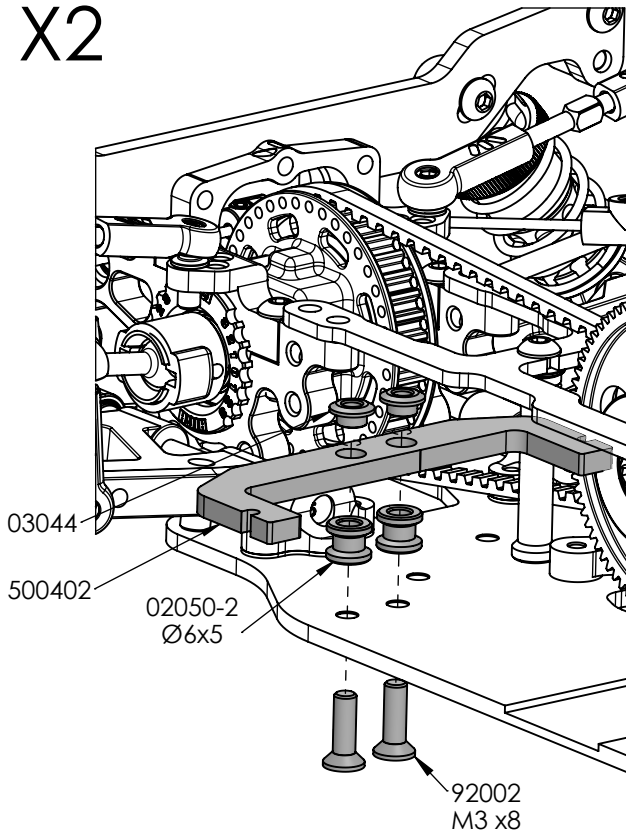

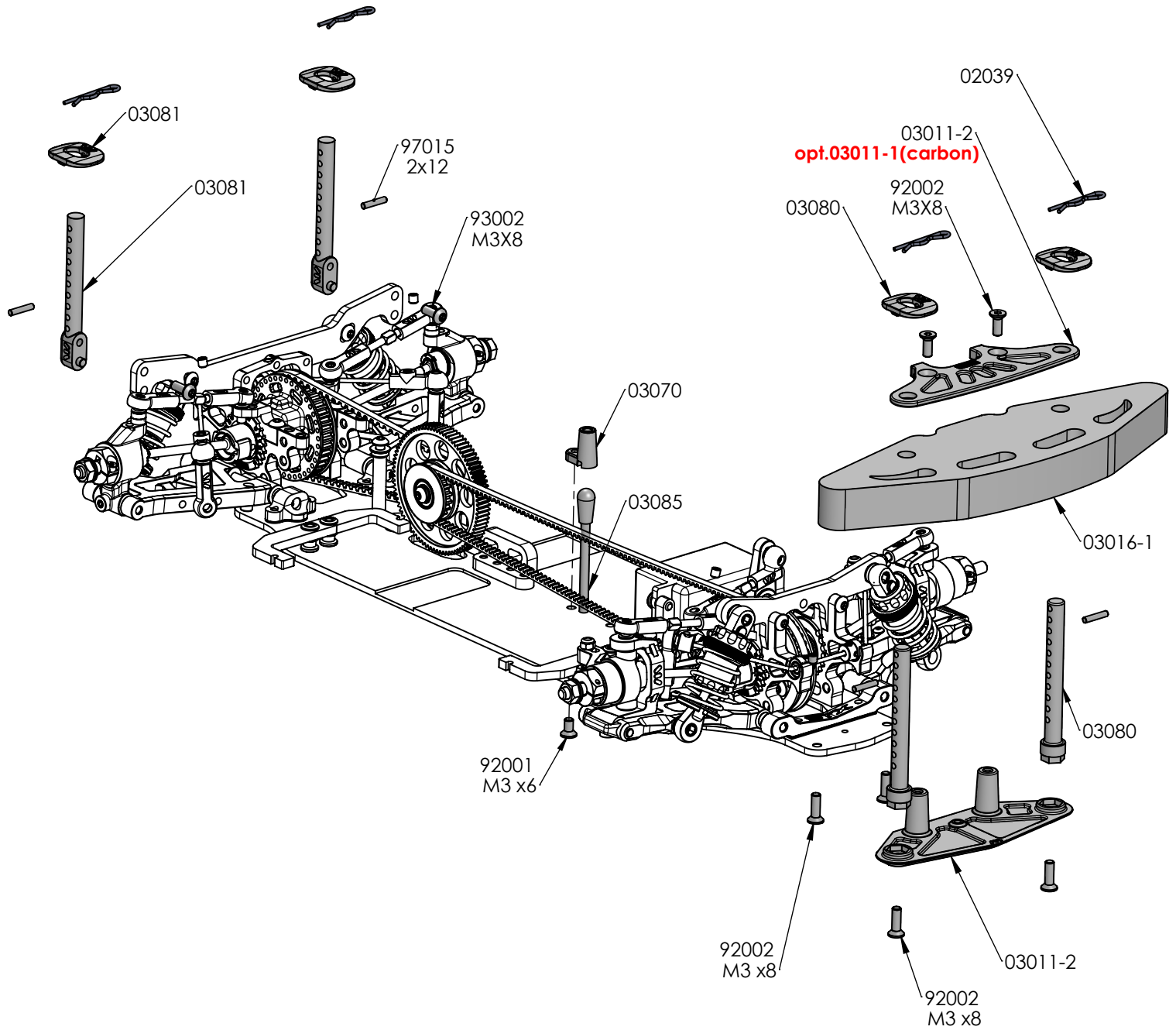



NAME \_\_\_\_\_  
 DATE \_\_\_\_\_  
 TRACK **ASPHALT**

### TRACK CONDITION

SURFACE  SMOOTH  MEDIUM  BUMPY  
 SIZE  TIGHT  MEDIUM  FAST  
 TRACTION  LOW  MEDIUM  HIGH

### TRANSMISSION

FRONT  SOLID AXLE OIL  
 DIFFERENTIAL  
 REAR  DIFFERENTIAL **2000**  
 PINION \_\_\_\_\_ SPUR GEAR \_\_\_\_\_  
 FINAL DRIVE RATIO \_\_\_\_\_

### SHOCKS

SPRINGS: COLOUR  
 FRONT **RED**  
 REAR **RED**  
 OIL: **400** **400**  
 PISTON: **3 HOLE** **3 HOLE**  
 LENGTH /mm \_\_\_\_\_

### ANTI-ROLL BAR

FRONT **1.3 mm**  
 REAR **1.2 mm**  
 BODY **WING**

### ROLL CENTER

FRONT **0.5 mm**  
 REAR **0.5 mm**

### ECCENTRIC BUSHINGS

#### FRONT - FRONT

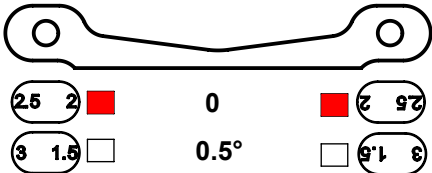

#### REAR - FRONT



#### REAR - REAR

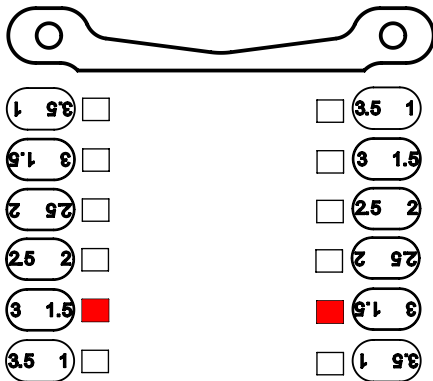

#### REAR - FRONT

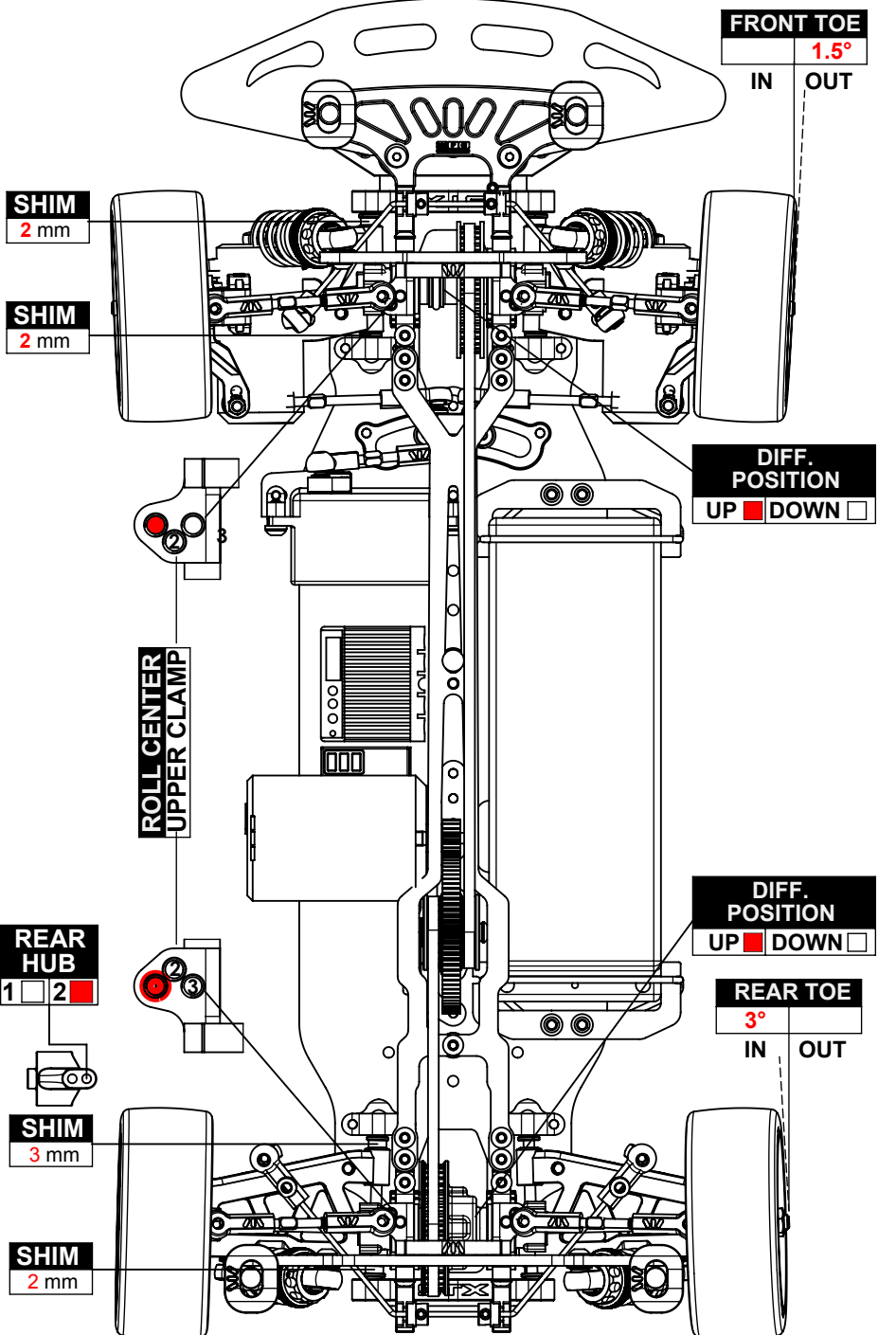
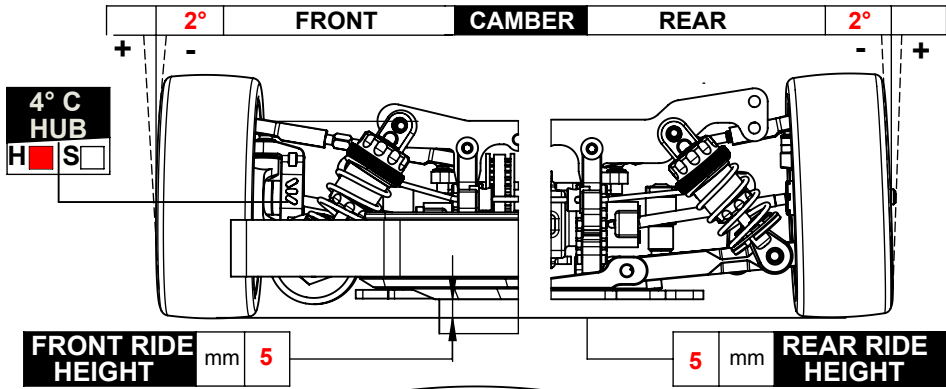
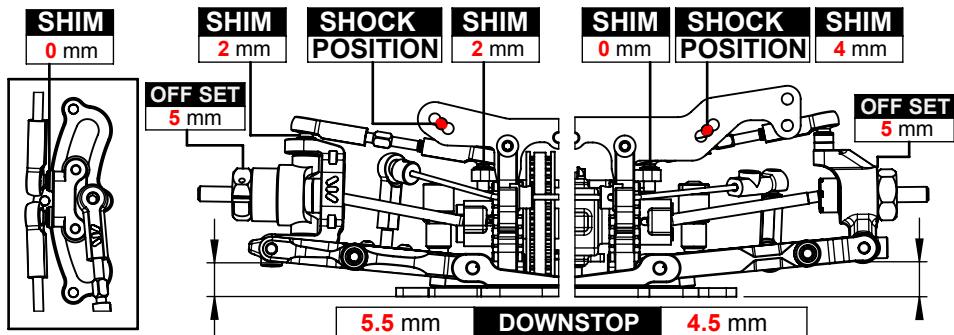



**W.R.C. world racing car s.r.l.**

Via Meucci, 23/B 36040 Brendola (VI) - ITALY - [commerciale@wrc-racing.com](mailto:commerciale@wrc-racing.com)

[www.wrc-racing.com](http://www.wrc-racing.com)