

Track Condition

Composition: Asphalt Carpet
 Surface: Smooth Medium Bumpy
 Traction: Low Medium High
 Size: Tight Medium Open
 Track Temp.: _____ Air Temp.: 17 degrees

Electronics

Motor: Fleta V2 17,5 Timing: fixed
 ESC: Euro Flety V2 Battery: MuchMore
 Spur: 102 Pinion: 43 Final Ratio: 4,51

Aerodynamics

Body: Racer Wing: Racer

Front Shocks Rear
Fuchsia - Spring - blue
LRP 50WT - Oil - LRP 50WT
3 - Piston - 3
3mm - Rebound (%) - 3mm

Anti-Roll Bar

1,5 1,2

Tires

Volante ETS - Inserts - _____
Volante ETS - Rims - _____
MuchMore V3 - Additive - _____
30min - Additive Time - _____

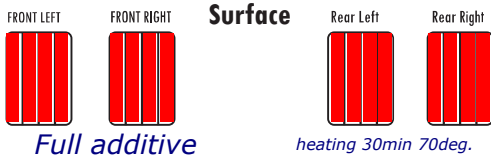

Transmission

_____ - Oil - 5000
 _____ - Oil Weight (Grs) - _____
 _____ - Setting - _____
 Spool

Roll Center

- Setting - _____

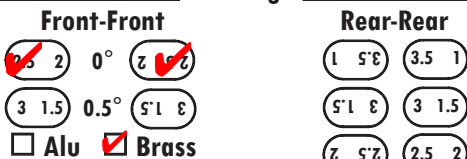

Front-Rear & Rear-Front

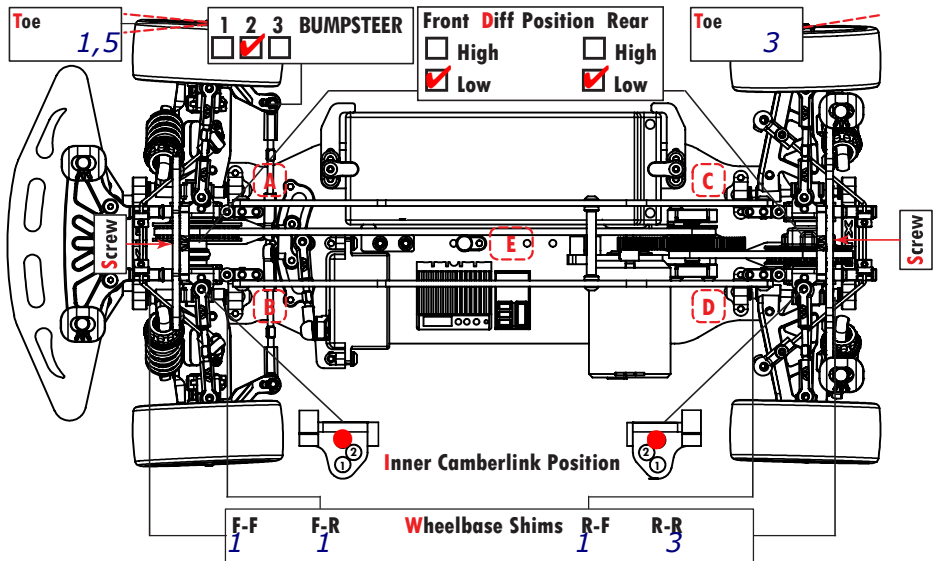
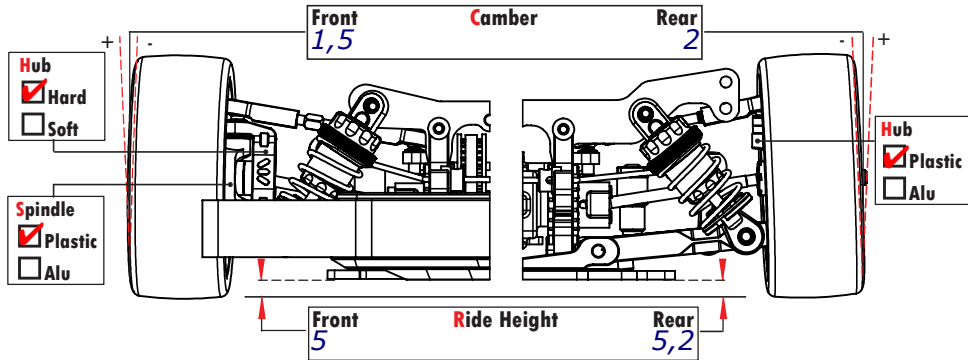
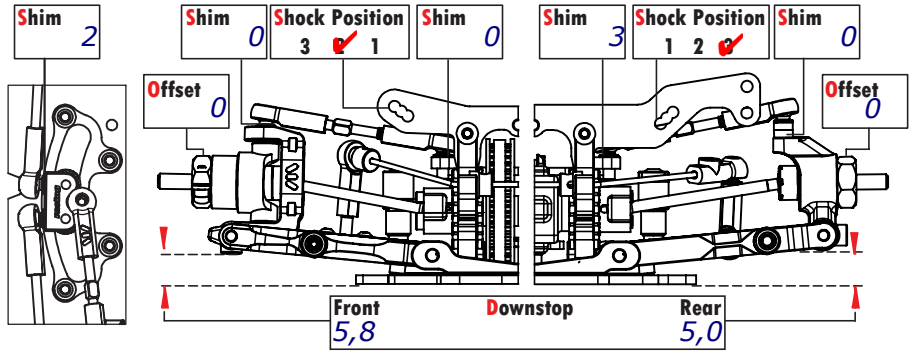

Balance Weight (Grs) - A: _____ B: _____ C: _____ D: _____ E: _____
 Total Car Weight (Grs): 1327g

Notes

- Brass weights all around
- 0,5mm spacers under the blocks all around except Front Front - there was none.
- 6000mah Much More 7,4V FD4 Battery
- Handout Motor
- Best Lapttime 21,9