

Track Condition

- Composition: Asphalt Carpet
 Surface: Smooth Medium Bumpy
 Traction: Low Medium High
 Size: Tight Medium Open
 Track Temp.: _____ Air Temp.: _____

Electronics

- Motor: _____ Timing: _____
 ESC: _____ Battery: _____
 Spur: _____ Pinion: _____ Final Ratio: _____

Aerodynamics

- Body: _____ Wing: _____

Front Shocks Rear

- Spring - _____
 - Oil - _____
 - Piston - _____
 - Rebound (%) - _____

Anti-Roll Bar

- Tires**
 - Inserts - _____
 - Rims - _____
 - Additive - _____
 - Additive Time - _____



Transmission

- Oil - _____
 - Oil Weight (Grs) - _____
 - Setting - _____
 Spool

Roll Center

- Setting - _____

Front-Front

(2.5 2 0° 2 2.5 2)

(3 1.5 0.5° 3 1.5 3)

Alu Brass

Rear-Rear

(1 3.5 3.5 1)

(1.5 3 3 1.5)

(2 2.5 2 2.5 2)

(2.5 2 2 2.5 2)

(3 1.5 3 1.5 3)

(3.5 1 1 3.5 3)

Alu Brass

Front-Rear & Rear-Front

(2.5 2 Standard Position 2 2.5 2)

FR: Alu Brass

RF: Alu Brass

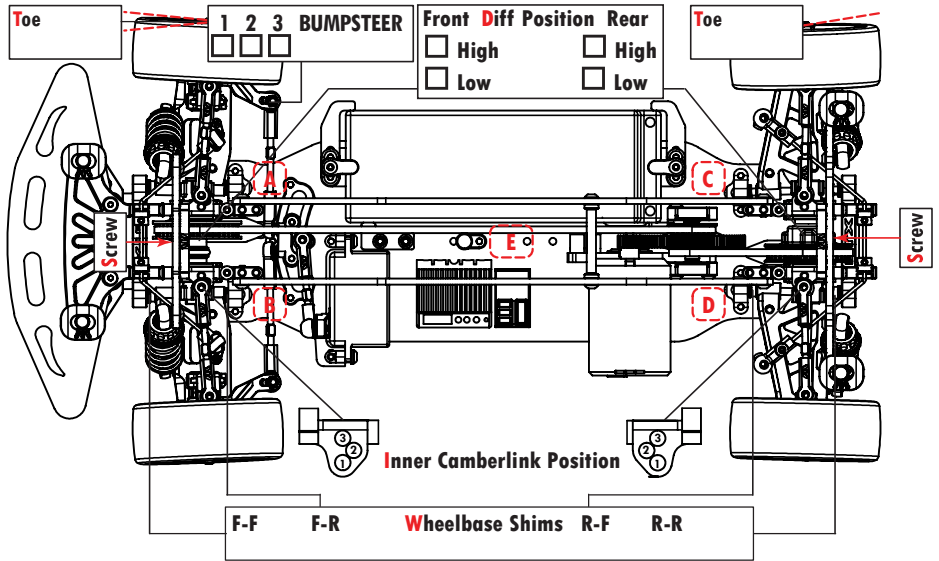
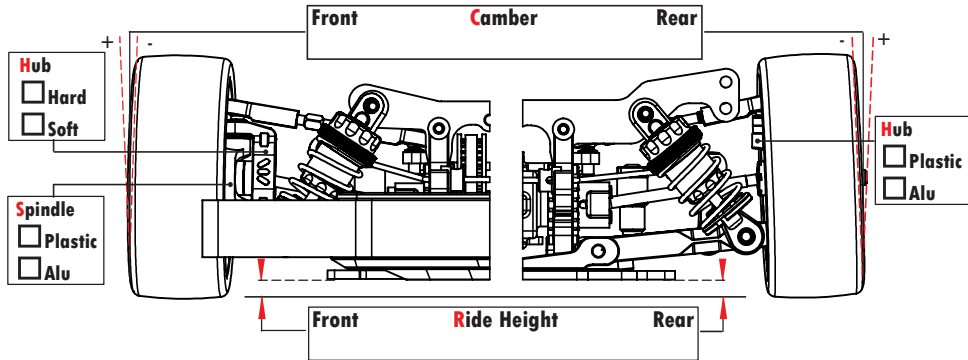
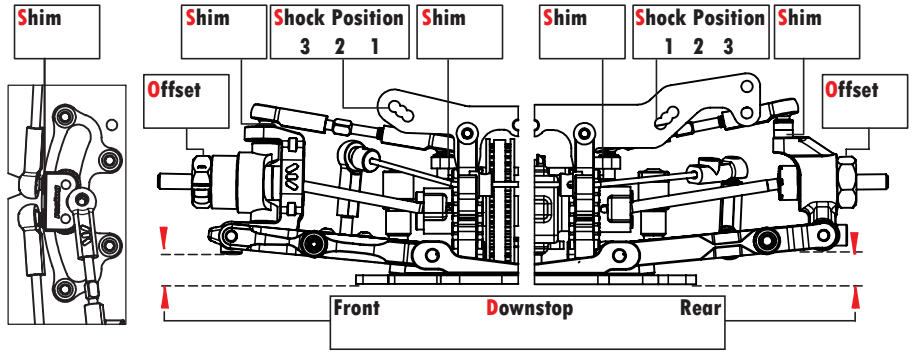

Balance Weight (Grs) - A: _____ B: _____ C: _____ D: _____ E: _____

Total Car Weight (Grs): _____

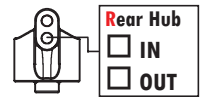

Notes