

# STX017

## Track Condition

- Composition:  Asphalt  Carpet  
 Surface:  Smooth  Medium  Bumpy  
 Traction:  Low  Medium  High  
 Size:  Tight  Medium  Open  
 Track Temp.: \_\_\_\_\_ Air Temp.: \_\_\_\_\_

## Electronics

- Motor: \_\_\_\_\_ Timing: \_\_\_\_\_  
 ESC: \_\_\_\_\_ Battery: \_\_\_\_\_  
 Spur: \_\_\_\_\_ Pinion: \_\_\_\_\_ Final Ratio: \_\_\_\_\_

## Aerodynamics

- Body: \_\_\_\_\_ Wing: \_\_\_\_\_

### Front Shocks Rear

- Spring - \_\_\_\_\_  
 - Oil - \_\_\_\_\_  
 - Piston - \_\_\_\_\_  
 - Rebound (%) - \_\_\_\_\_

## Anti-Roll Bar

## Tires

- Inserts - \_\_\_\_\_  
 - Rims - \_\_\_\_\_  
 - Additive - \_\_\_\_\_  
 - Additive Time - \_\_\_\_\_



## Transmission

- Gear  Ball - Differential -  Gear  Ball  
 - Oil - \_\_\_\_\_  
 - Oil Weight (Grs) - \_\_\_\_\_  
 - Setting - \_\_\_\_\_  
 Spool

## Roll Center

- Setting - \_\_\_\_\_

### Front-Front

- (2.5 2) 0° (2 2.5)  
 (3 1.5) 0.5° (1.5 3)  
 Alu  Brass

### Rear-Rear

- (1 3.5) (3.5 1)  
 (5 1.5) (3 1.5)  
 (2 2.5) (2.5 2)  
 (2.5 2) (2 2.5)  
 (3 1.5) (1.5 3)  
 (3.5 1) (1 3.5)  
 Alu  Brass

### Front-Rear & Rear-Front

- (2.5 2) Standard Position (2 2.5)  
 FR:  Alu  Brass  
 RF:  Alu  Brass

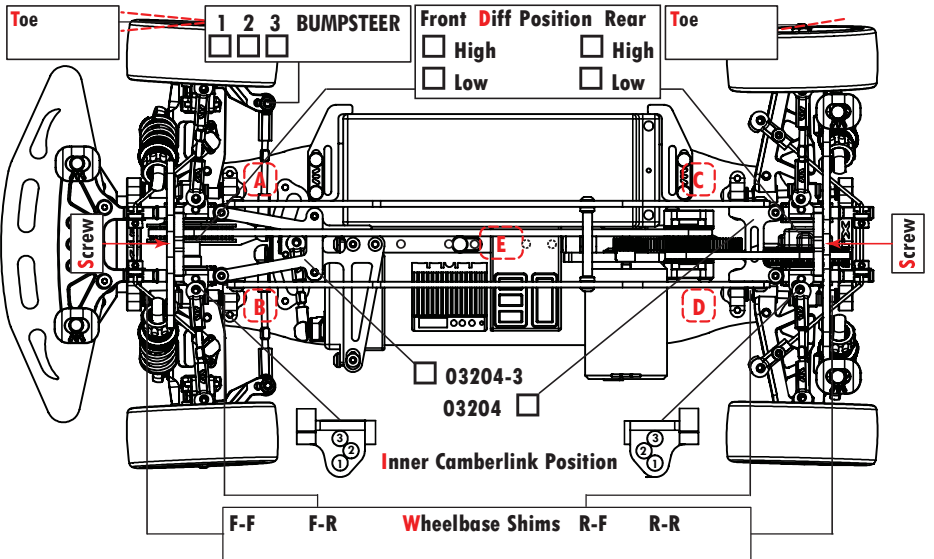
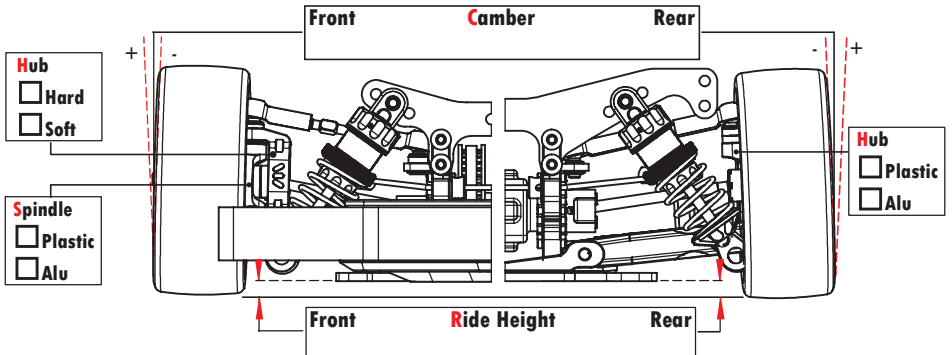
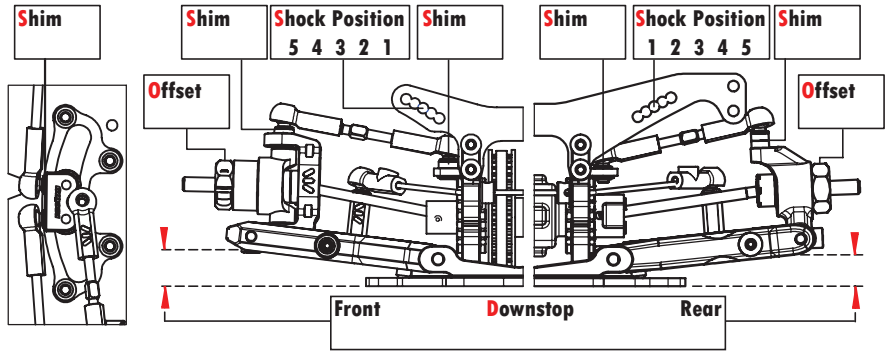

Balance Weight (Grs) - A: \_\_\_\_\_ B: \_\_\_\_\_ C: \_\_\_\_\_ D: \_\_\_\_\_ E: \_\_\_\_\_

Total Car Weight (Grs): \_\_\_\_\_

## Notes