

# GT<sup>X</sup> SETUP SHEET

NAME \_\_\_\_\_  
 DATE \_\_\_\_\_  
 TRACK \_\_\_\_\_

## TRACK CONDITION

**SURFACE**  SMOOTH  MEDIUM  BUMPY  
**SIZE**  TIGHT  MEDIUM  FAST  
**TRACTION**  LOW  MEDIUM  HIGH

## TRANSMISSION

**PINION** 1st: 19 2nd: 24  
**SPUR GEAR** 1st: 61 2nd: 57

## CLUTCH SETTINGS

**SHOE**  STANDARD  OPTIONAL  
**SPRING** 0.50  
**BELL CLEARANCE /mm** 0.50  
**BELL AXIAL PLAY /mm** 0.10



## SHOCKS SETTINGS

	FRONT	REAR
<b>SPRINGS</b>		
<b>OIL</b>	600	600
<b>PISTON</b>	ORIGINAL	ORIGINAL
<b>LENGHT /mm</b>		
<b>PRELOAD /mm</b>		
<b>REBOUND %</b>	10%	10%

## ANTI-ROLL BAR

<b>FRONT</b>	2.3
<b>REAR</b>	3.2

## ARM BUSHES ORIENTATION

 + 0.5mm / - 0.5mm     + 1.0mm / - 1.0mm     + 1.5mm / - 1.5mm

## BATTERY MOUNT

STANDARD  BRASS

## ENGINE MOUNT

STANDARD  BRASS

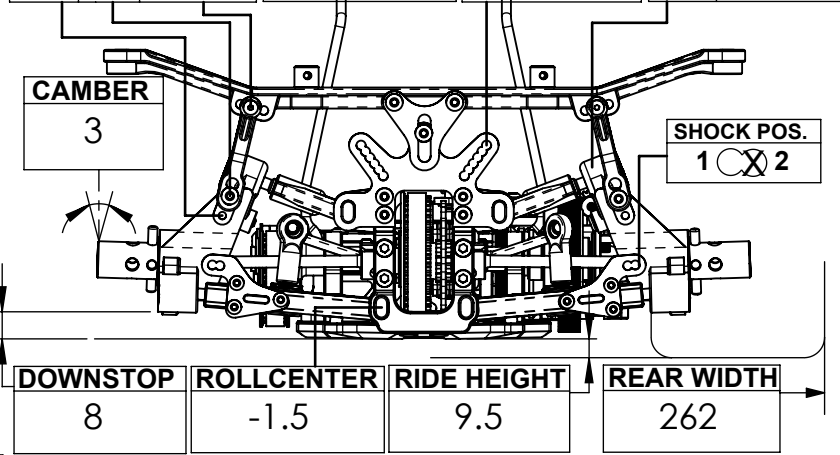
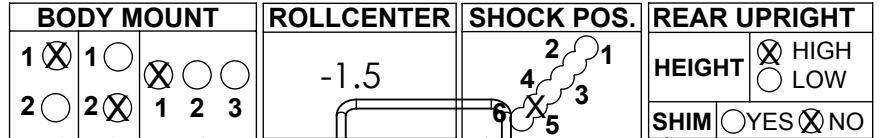
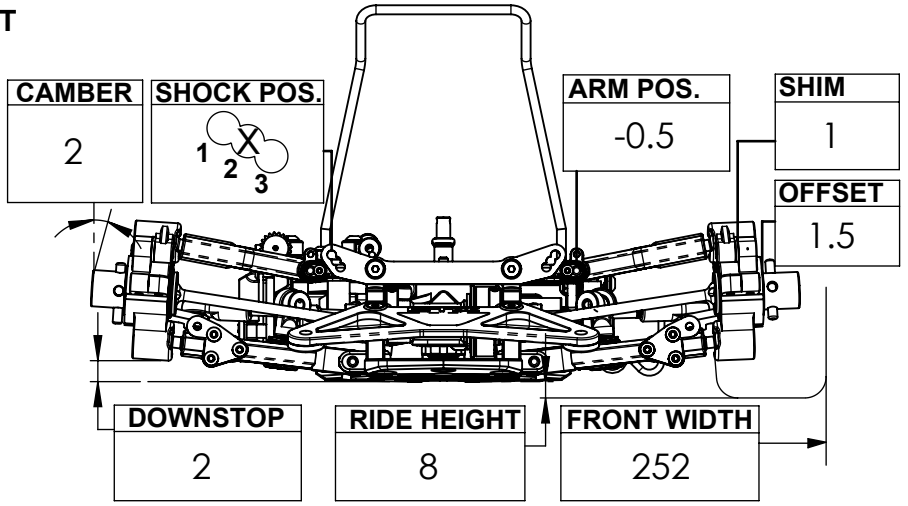

**DISC**  
 YES  
 NO

**TOE°**  
 2.5

**SERVO SAVER POS.**  
 FRONT (1)  
 REAR (2)

**DISC**  
 YES  
 NO

**TOE°**  
 1.5

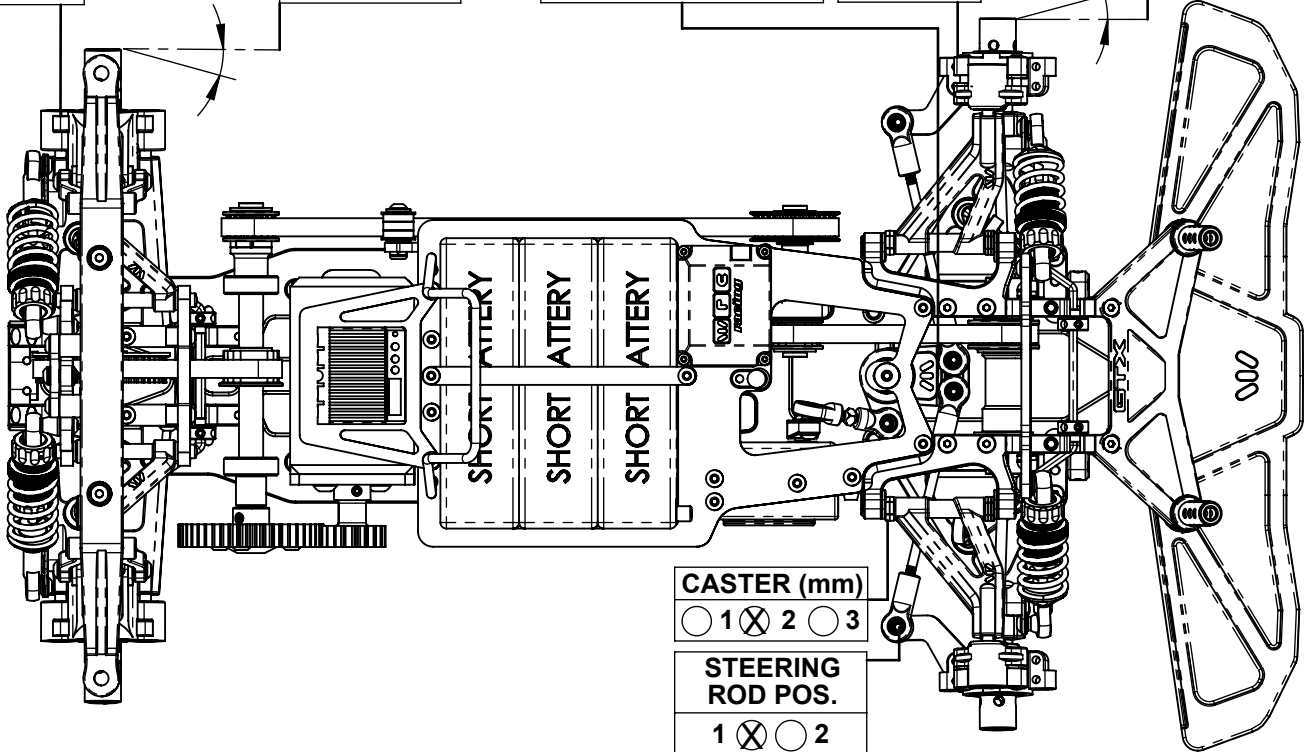

**CASTER (mm)**  
 1  2  3  
**STEERING ROD POS.**  
 1  2