

# GT~~X~~ SETUP SHEET

NAME Toni Gruber  
 DATE 10.-11.6.2017  
 TRACK SM-Lauf Leipzig

## TRACK CONDITION

SURFACE  SMOOTH  MEDIUM  BUMPY  
 SIZE  TIGHT  MEDIUM  FAST  
 TRACTION  LOW  MEDIUM  HIGH

## TRANSMISSION

PINION 1st: 19 2nd: 24  
 SPUR GEAR 1st: 61 2nd: 56

## CLUTCH SETTINGS

SHOE  STANDARD  OPTIONAL

## SPRING

BELL CLEARANCE /mm

BELL AXIAL PLAY /mm

## SHOCKS SETTINGS

	FRONT	REAR
SPRINGS	<u>WRC ws</u>	<u>Mugen sr</u>
OIL	<u>600</u>	<u>800</u>
PISTON	<u>1</u>	<u>2</u>
LENGHT /mm	<u>—</u>	<u>—</u>
PRELOAD /mm	<u>—</u>	<u>—</u>
REBOUND %	<u>20%</u>	<u>20%</u>

## ANTI-ROLL BAR

FRONT 2,4  
 REAR 3,0 geschliffen

## ARM BUSHES ORIENTATION

+0.5mm / -0.5mm     +1.0mm / -1.0mm     +1.5mm / -1.5mm

## BATTERY MOUNT

STANDARD  BRASS

## ENGINE MOUNT

STANDARD  BRASS

CAMBER  
 R 3°  
 L 3,5°

SHOCK POS.  
 1  2  3

ARM POS.  
-1,5  
1mm

SHIM  
3

OFFSET  
0

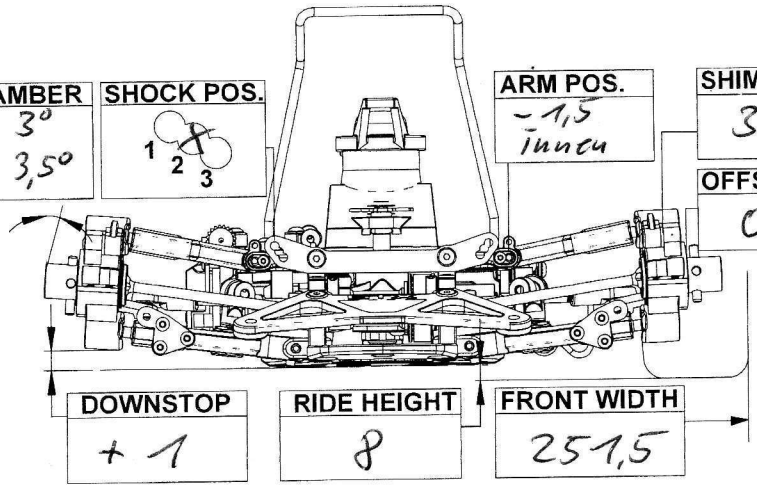

BODY MOUNT  
 1  1  2  3   
 2  2  1  2  3

ROLLCENTER

SHOCK POS.  
 2  1   
 4  3   
 6  5

REAR UPRIGHT  
 HEIGHT  HIGH  LOW  
 SHIM  YES  NO

CAMBER  
 R 3°  
 L 3°

SHOCK POS.  
 1  2

DOWNSTOP  
1 + 8,5

ROLLCENTER  
-1,5

RIDE HEIGHT  
9

REAR WIDTH  
264,5

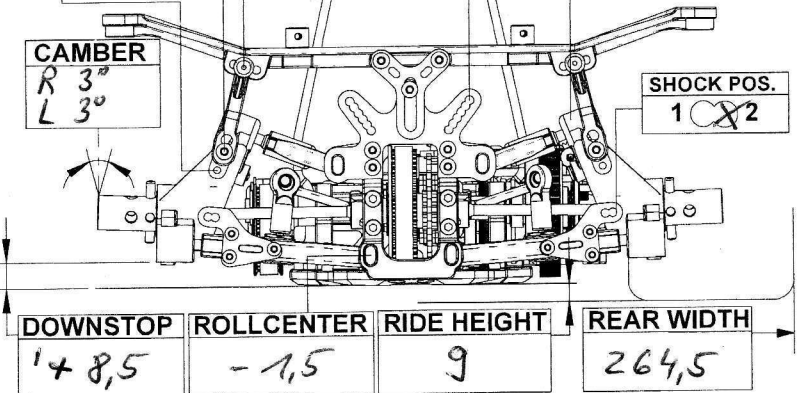

DISC  
 YES  
 NO

TOE°  
4°

FLOATING PLATE  
 YES  
 NO

SERVO SAVER POS.  
 FRONT (1)  
 REAR (2) M.H.E

DISC  
 YES  
 NO

TOE°  
 R +0,5  
 L +0,5

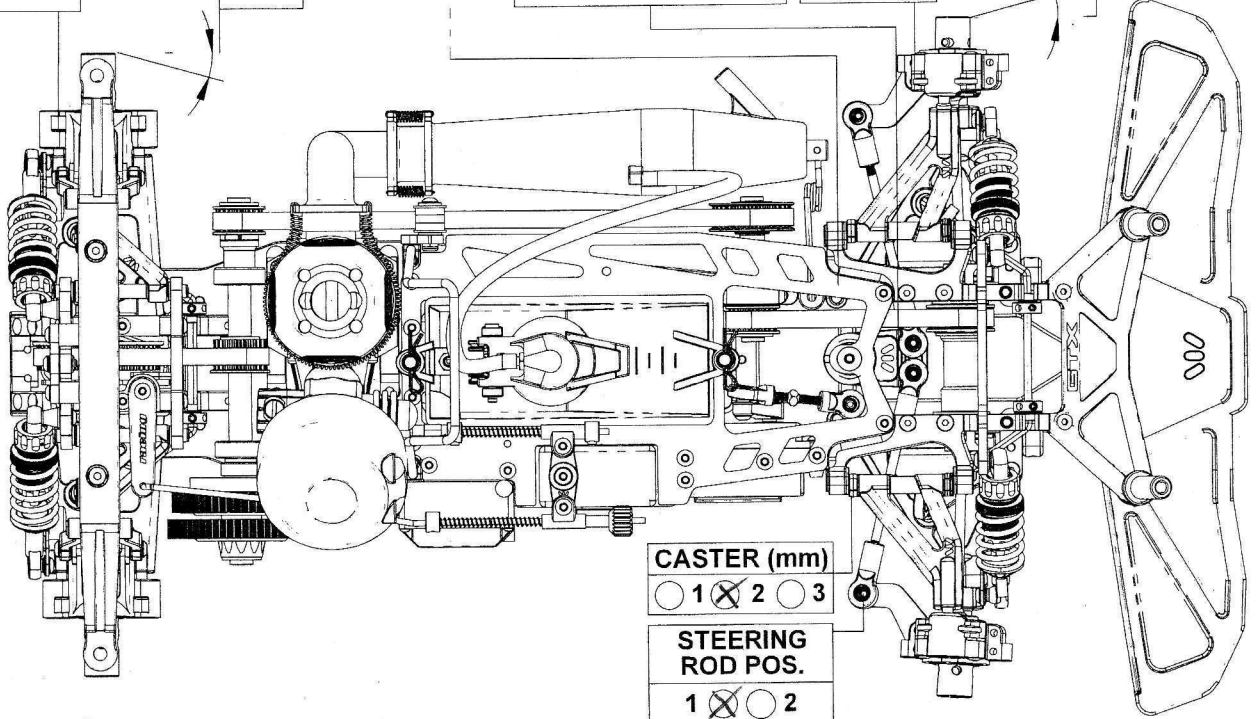

CASTER (mm)  
 1  2  3

STEERING ROD POS.  
 1  2

*Schnellste Runde 15,9s*