

F18.2

new generation rc car

**1/10 SCALE ELECTRIC
FORMULA CAR**



INSTRUCTION MANUAL



www.wrc-racing.com

F18.2

TECHNICAL INFORMATION

- TRANSMISSION: 2 DRIVE WHEELS
- BODY: LEXAN FORMULA MODEL (NOT INCLUDED)
- ADJUSTABLE FRONT TOE, CAMBER AND CASTER
- ADJUSTABLE REAR HEIGHT
- BUMPER /FRONT BACKSTOP
- CARBON CHASSIS 2mm
- FULL BALL BEARING
- ADJUSTABLE DIFFERENTIAL

TECHNICAL DATA

- LENGHT418 MM.
- WIDTH190 MM.
- ADJUSTABLE WHEEL BASE269-265MM.
- WEIGHT CHASSIS.....1080 GR.

REQUIRED BUT NOT INCLUDED IN THE KIT

ADDITIONAL ITEMS NEEDED FOR COMPLETION

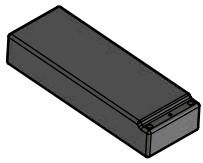

LIPO BATTERY 7.4 V.



ELECTRIC MOTOR
PINION GEAR

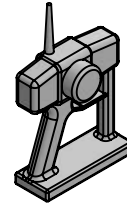

TRANSMITTER



RECEIVER



SPEED CONTROLLER

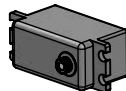

LOW PROFILE STEERING SERVO



AA ALKALINE BATTERIES
FOR TRANSMITTER



WHEEL - TYRES - INSERTS
INCLUDED



LIPO BATTERY TAPE



LEXAN BODY+DECALS
INCLUDED

TOOLS REQUIRED

THESE TOOLS ARE NOT INCLUDED IN THE KIT BUT ARE REQUIRED FOR PROPER ASSEMBLY



SOCKET:
5.5 MM
7.0 MM

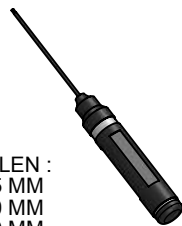

ALLEN :
1.5 MM
2.0 MM
3.0 MM

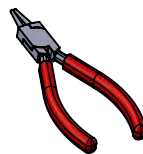

RING PLIERS



SIDE CUTTER



SCISSORS

NOTICE:

THE FOLOWING ITEMS ARE NEEDED FOR COMPLETION PF THE STX; THEY ARE NOT INCLUDED IN THIS KIT (UNLESS NOTED) AND SHOULD BE OBTAINED FROM YOUR LOCAL HOBBY SHOP.
BE SURE TO READ THE INSTRUCTION COMPLETELY PRIOR TO ASSEMBLY

F18.2

INTRODUCTION

F18 is a new generation high quality 1/10 scale touring car.
F18 is supplied in a box equipped with Instruction Manual.
Its use is intended for more than 16 years old persons with experience on rc model car field.
Children and all the persons without this requirement MUST have direct supervision of a knowledgeable adult responsible.

SAFETY PRECAUTIONS

Instruction Manual MUST be read and fully understood before to start building and operating functions.
Always keep Instruction Manual in safety place, ready to be consulted for any reference you need.
Use only original WRC spare parts.

GENERAL INFORMATION

Assemble the kit only away from the reach of children.
Follow the building and operating instructions using the utmost care.
Don't put any part of your body inside rotating and moving elements as this may cause damage or serious injury.
Check and clean the model before putting it away.
Don't use your model car in public places or in roads and areas where it could generate conflict with person or vehicular traffic.
The model car is controlled by radio: you MUST put great care to avoid loss of radio control always keeping a safety margin all around your model in order to prevent any collision.
Operating frequency: check and be sure it is clear and not shared with anybody at same time; it could cause loss of control of the RC model.
Always turn on your transmitter before you turn on the receiver in the car and always turn off the receiver before you turn off your transmitter.
Keep the wheels of the model off the ground when checking the operation of the radio equipment.
Disconnect the battery pack before storing your model.

WARRANTY

WRC guarantees this model kit to be free from defects in both material and workmanship within 30 days of purchase.
The total monetary value under warranty will in no case exceed the cost of the original kit purchased.
This warranty doesn't cover any components damaged by use or modification or as result of wear.
Part or parts missing from this kit must be reported within 30 days of purchase.
No part or parts will be sent under warranty without proof of purchase.
If you find a defective or missing part, contact the local distributor.
Customer service and support will be provided through local hobby store.
No warranties are expressed or implied that cover damage caused by what is considered normal use or cover or imply how long any model cars' components or electric components will last before requiring replacement.
Due to the high performance level of this model car you will need to periodically maintain and replace consumable components; any and all warranty coverage will not cover replacement of any part or component damaged by neglect, abuse or improper or unreasonable use.
This includes but is not limited to damage from crashing, excessive moisture, improper use or no maintenance or user modifications which compromise the integrity of components.
Warranty will not cover components that are considered consumable on RC model car.
WRC doesn't pay nor refund on any component sent from WRC or its distributor for warranty.
WRC reserves the right to make final determination of the warranty status of any component or part
Use only original WRC spare part:

CUSTOMER SUPPORT

Please don't hesitate to contact WRC support at info@wrc-racing.com for any problem or question.
Also kindly visit our website www.wrc-racing.com to find last updates, set-up information, option parts and other information.

W.R.C. world racing car s.r.l.

Via Meucci, 23/B
36040 Brendola (VI)
ITALY

Phone: 0039 0 444 401138
fax: 0039 0 444 401139
E-mail: info@wrc-racing.com
Website: www.wrc-racing.com



F18.2

BAG 1

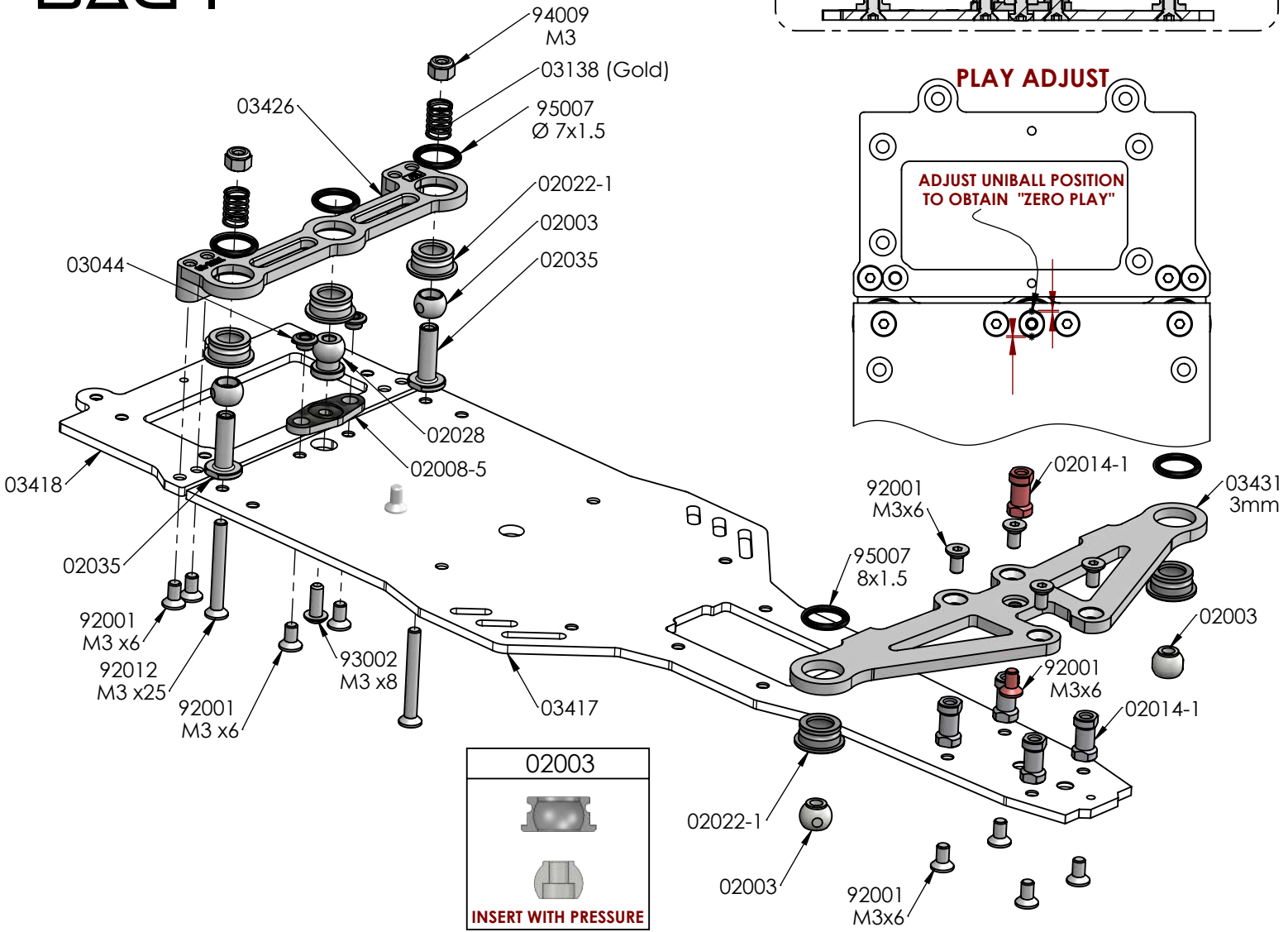
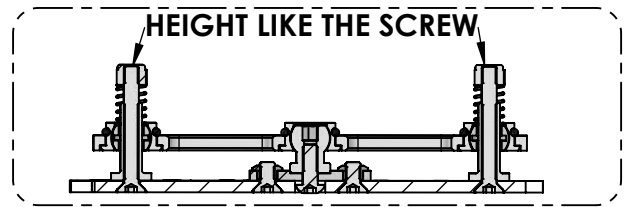

BAG 2

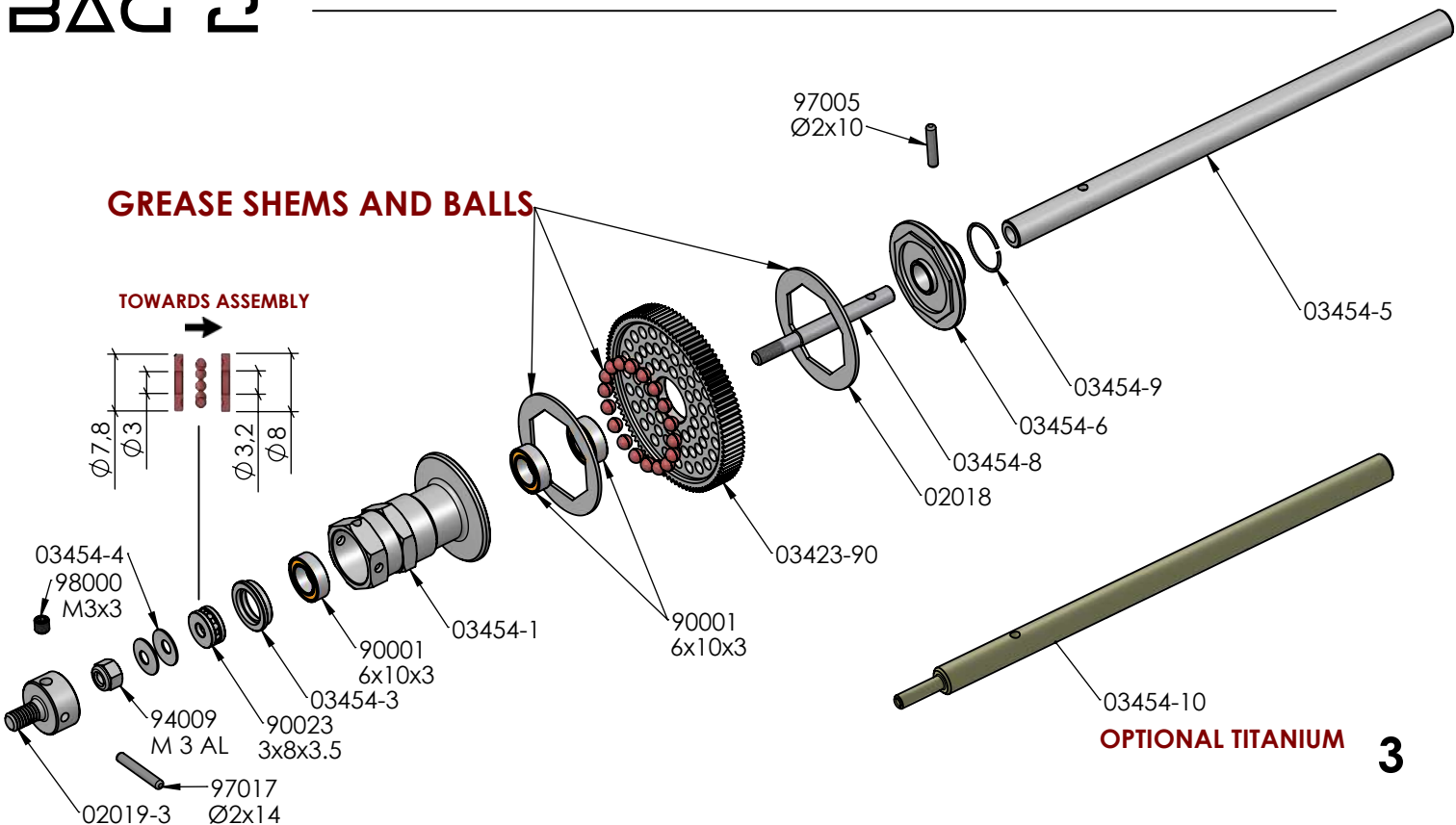

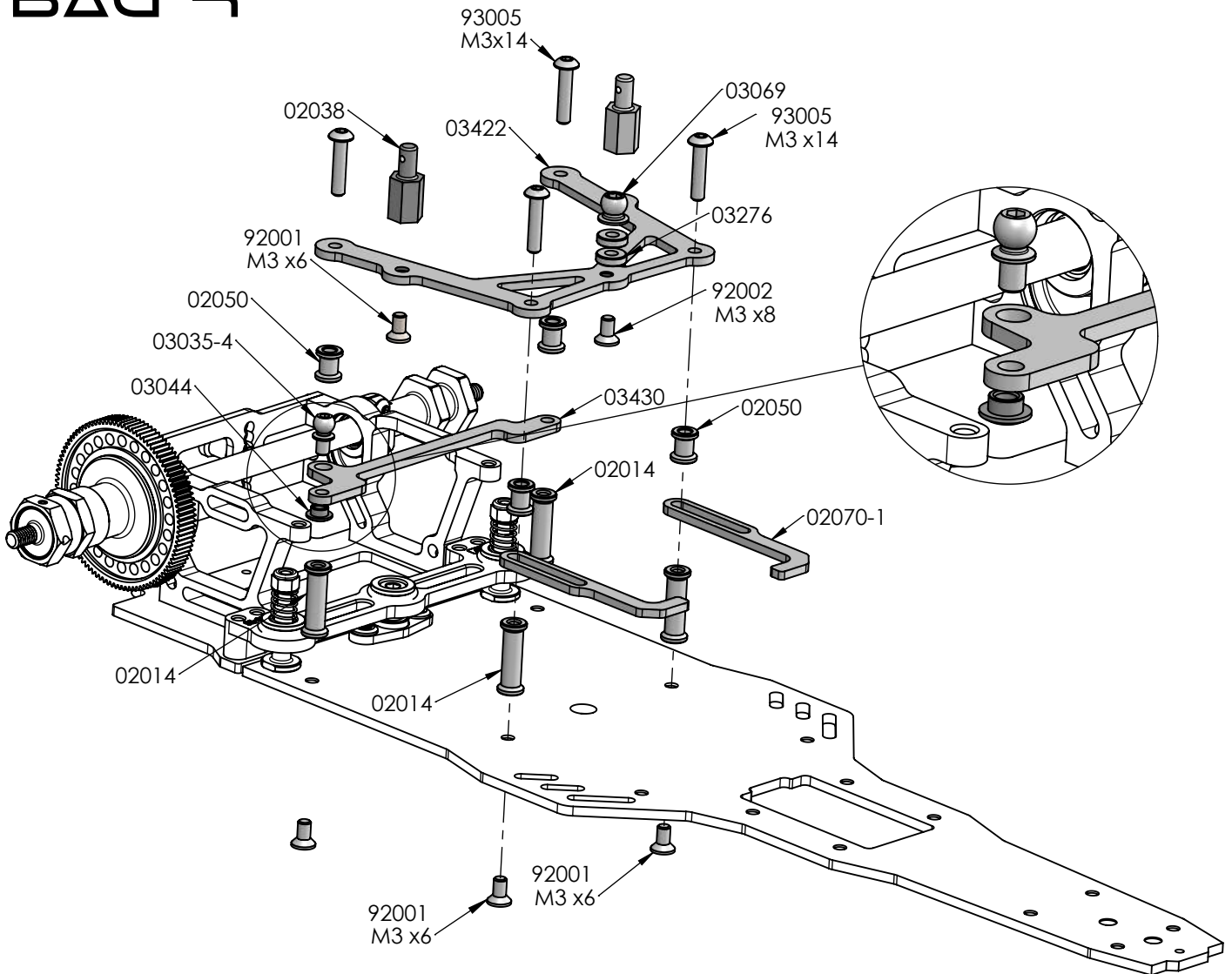
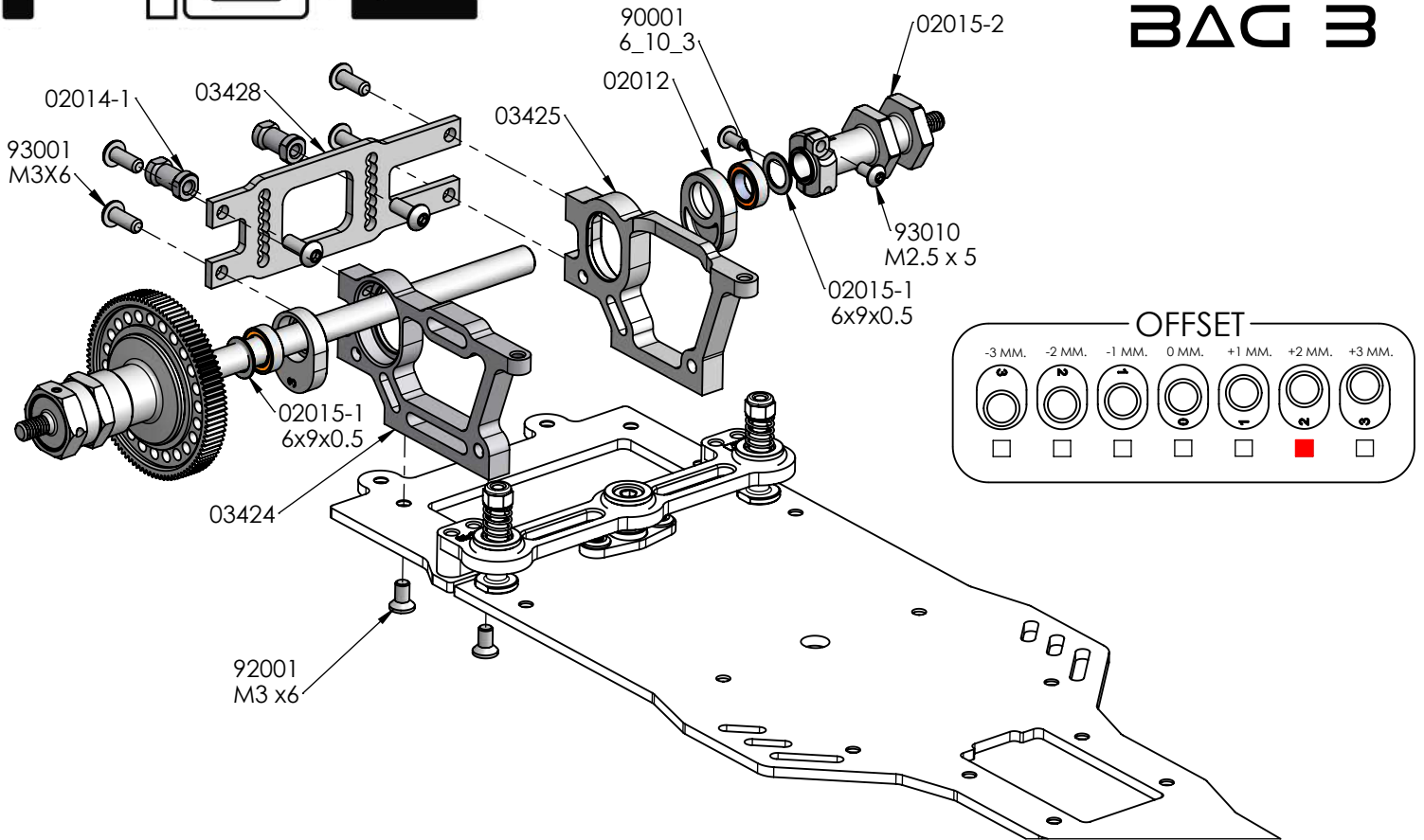

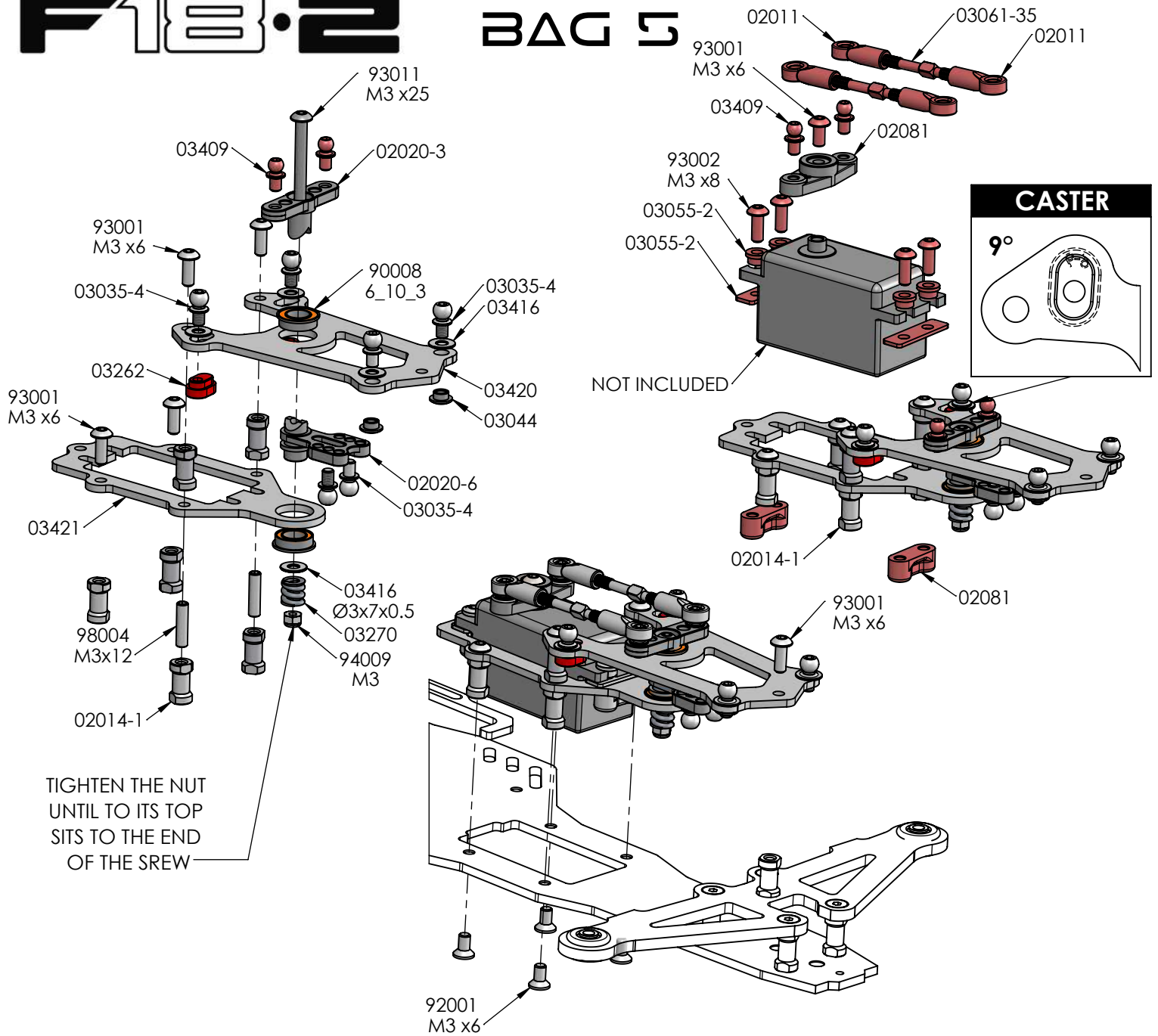

BAG 6

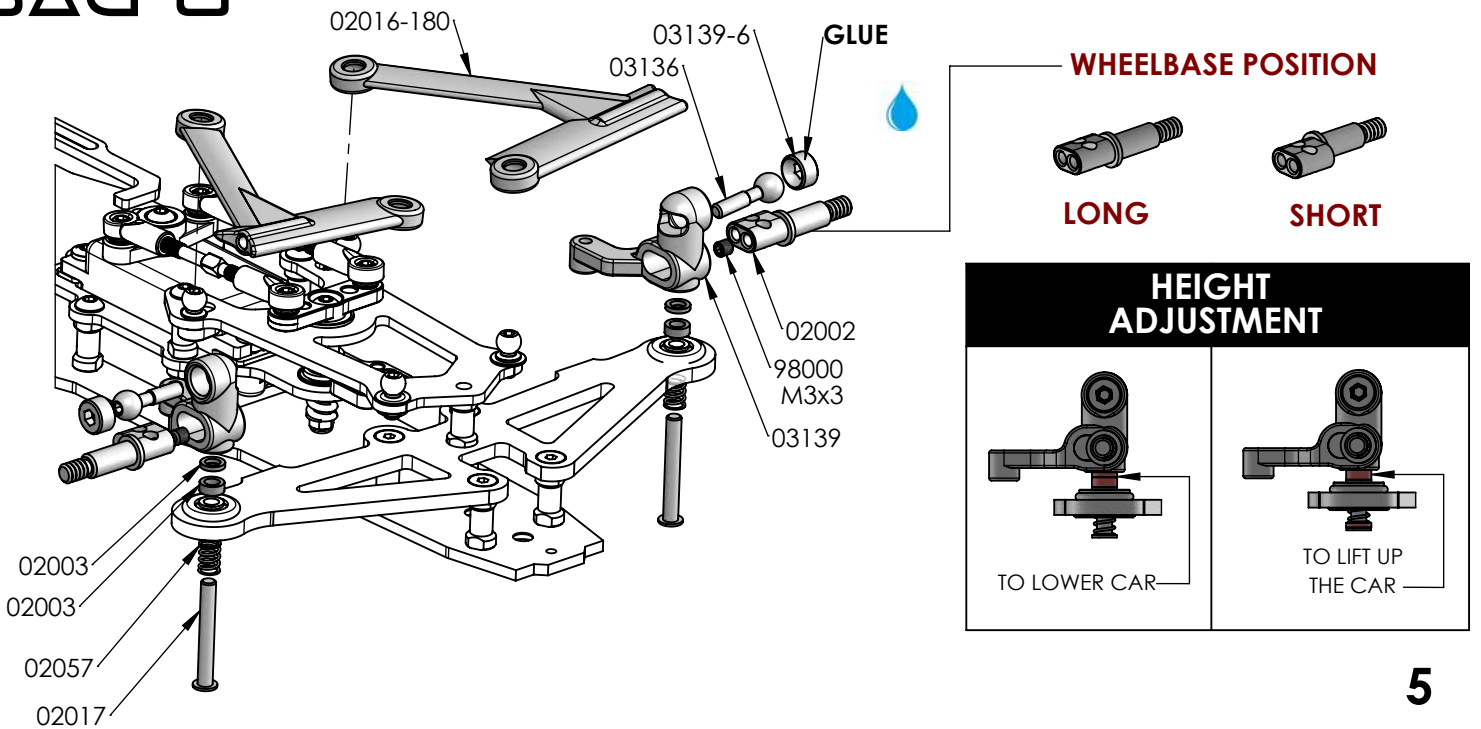

SPRINGS		
COD	Force (lb)	COLOUR
03170-5	2.1	BLACK
03170-6	2.2	YELLOW
03170-7	2.3	RED IN KIT
03170-8	2.6	BLUE
PROGRESSIVE SPRINGS		
03170-9	1.3-2.9	FUCHSIA
03170-10	1.4-3.5	GREEN

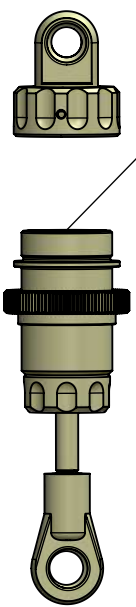
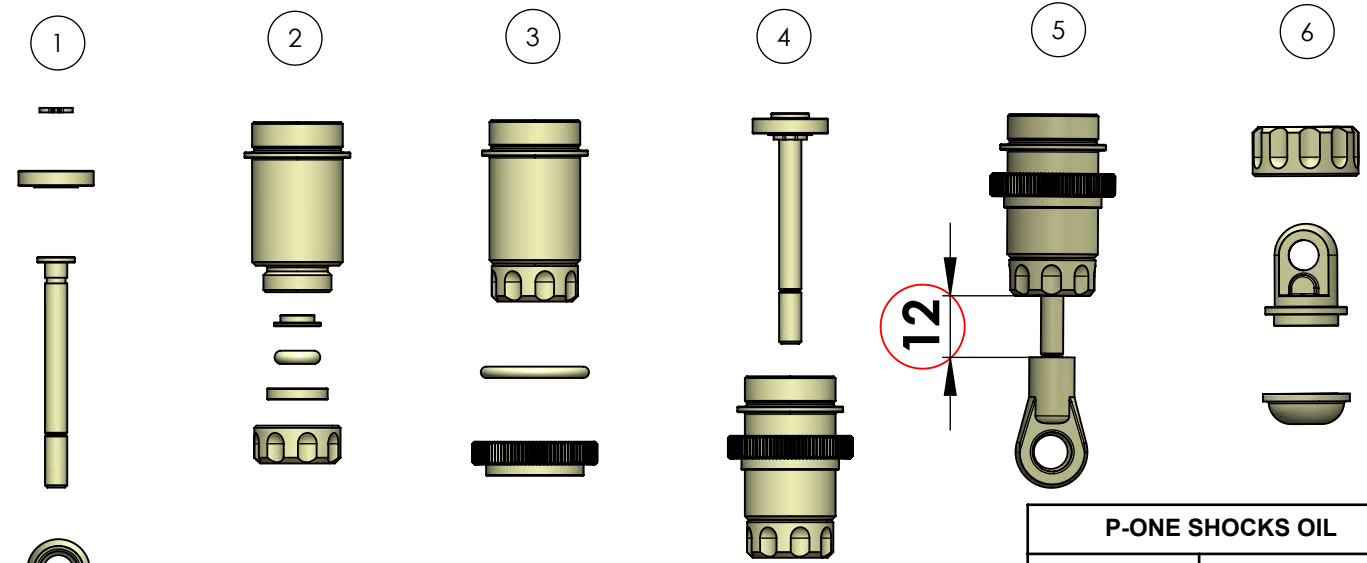
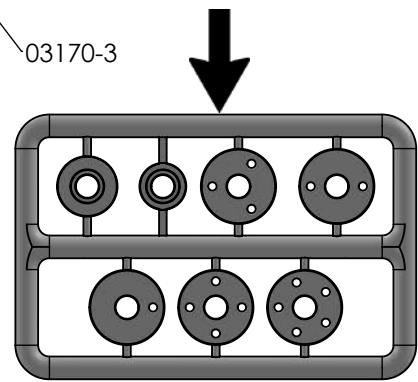
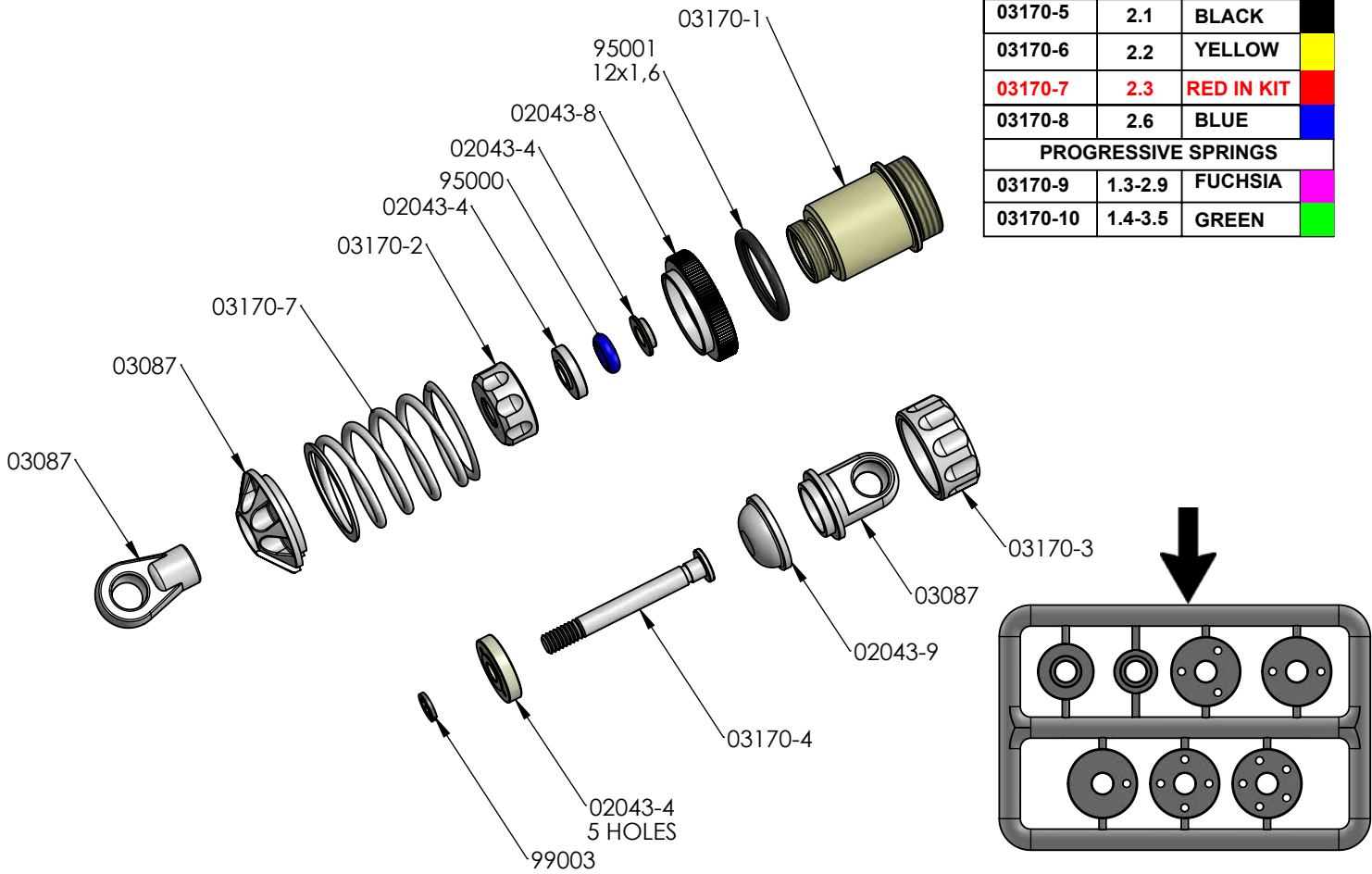

SHOCK FILLING

Fully extend the piston rod so the piston is at the bottom of the shock body.

Hold the shock upright and fill the shock body with shock oil as in the picture.

Let the oil settle and allow air bubbles to rise to the top. Slowly move the piston up and down until no more air bubbles appear. Add shock oil as necessary.

Pull the piston rod most of the way out of the shock bod. Let the shock rest for 5 minutes to allow the air bubbles to scape.

P-ONE SHOCKS OIL	
CODE	CST
SO-350	350
SO-400	400
SO-450	450
SO-500	500
SO-550	550
SO-600	600
SO-650	650
SO-700	700(IN KIT)
SO-800	800

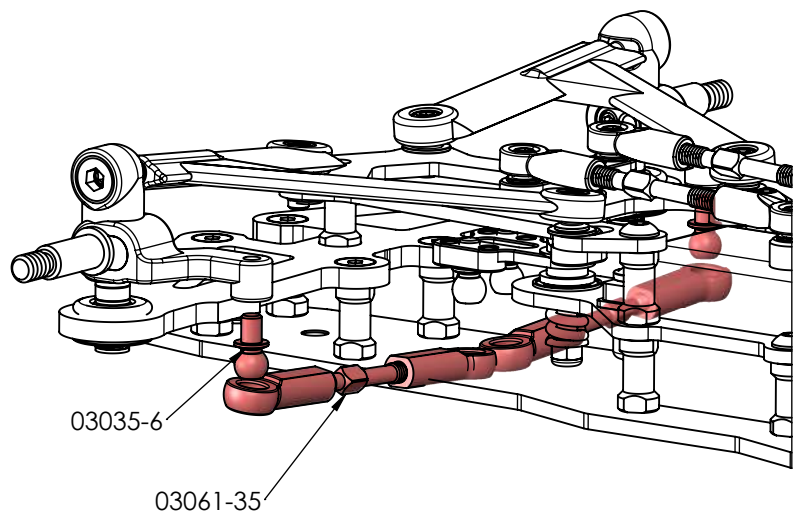
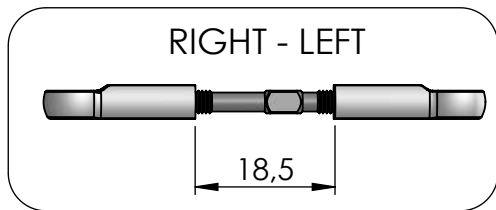
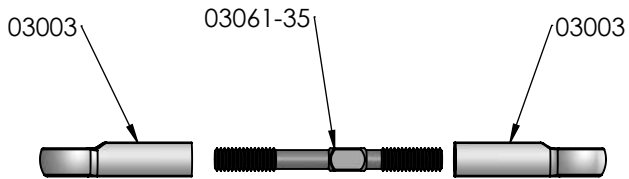
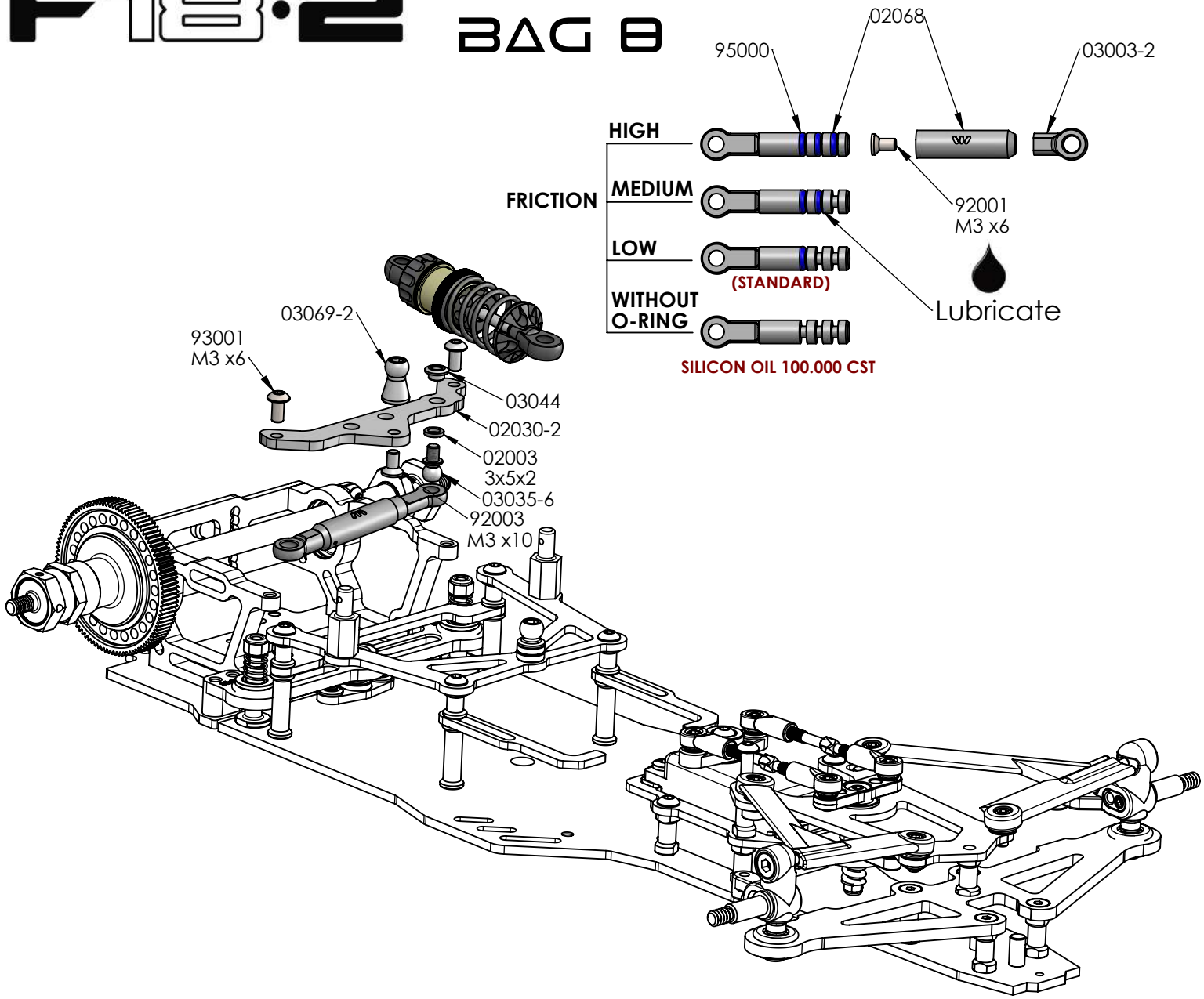

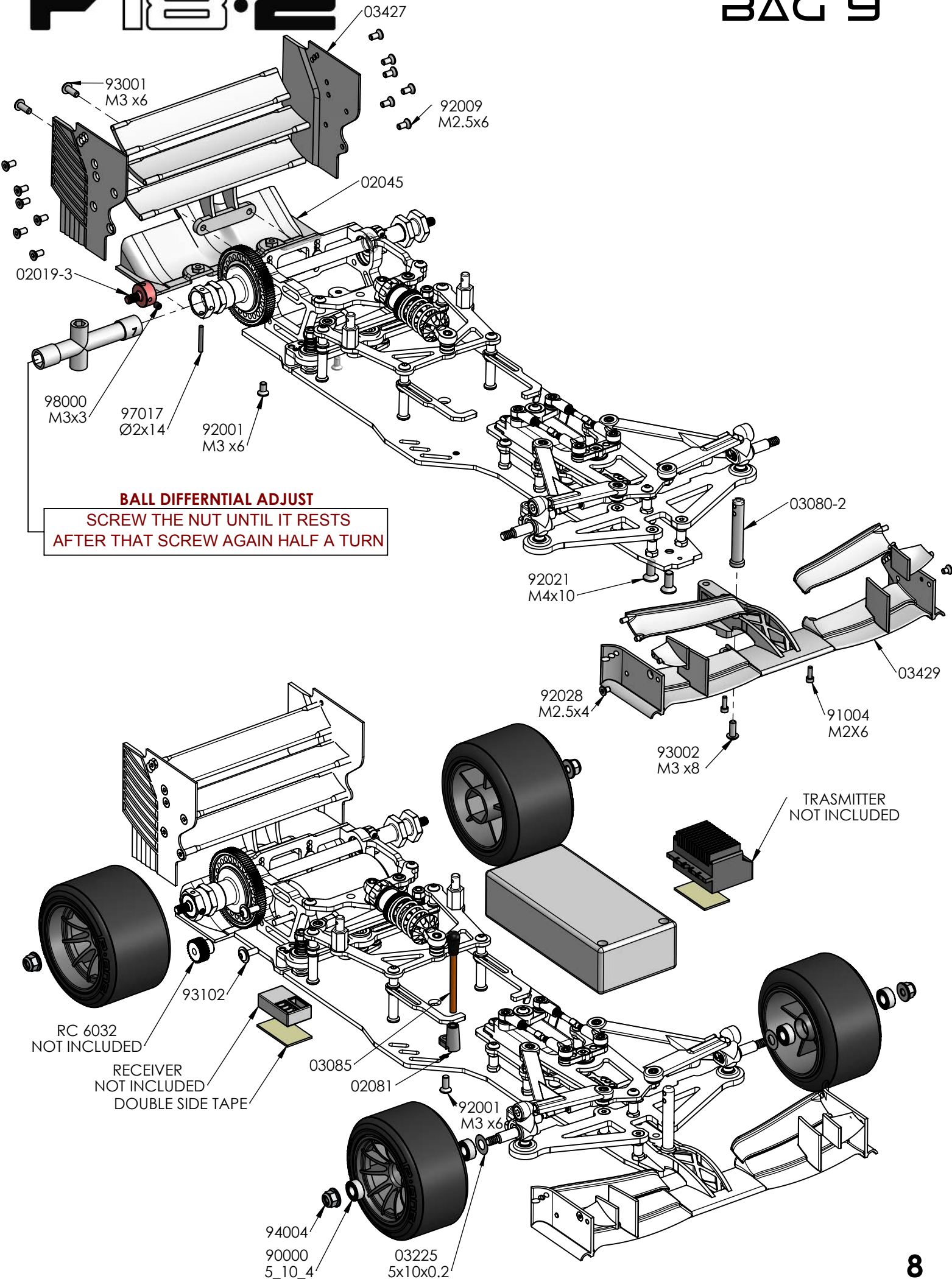

F18.2

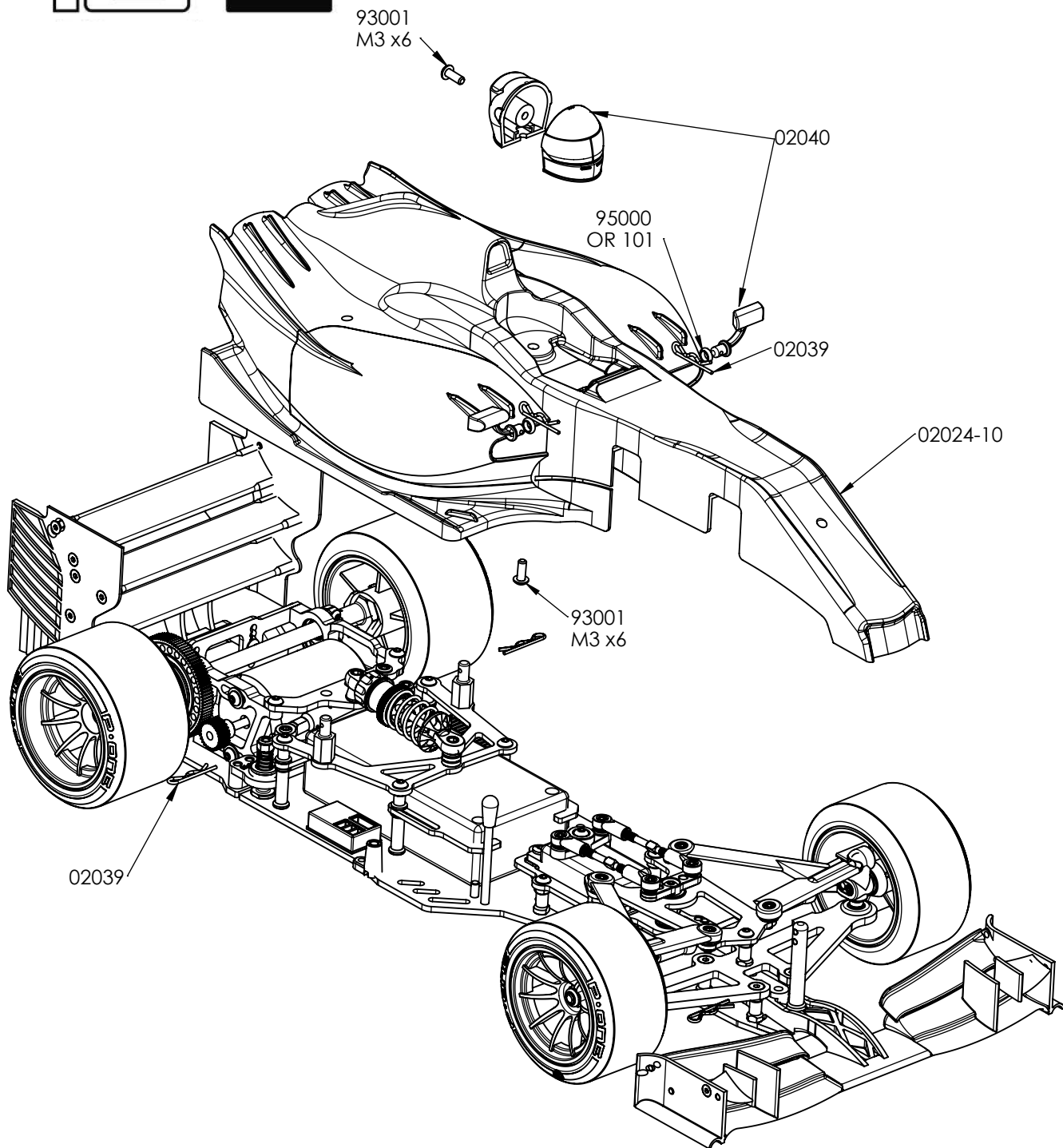

F18.2

NAME _____
 DATE _____
 TRACK _____

TRACK CONDITION

SURFACE CARPET ASPHALT
 TRACTION
 LOW MEDIUM HIGH

DRIVE RATIO

PINION _____ SPUR _____
90

BALL DIFF. TRANSMISSION

LOSE TIGHT

TYRES MODE TYPE

FRONT **P-ONE** **P01**
 REAR **P-ONE** **P01**

SPRINGS

FRONT **GREY** (G)
 REAR **GOLD** (GLD)
 DAMPER **RED** (R)

OIL VISCOSITY PISTON HOLES

DAMPER **700** **5 HOLES**
 SIDE SHOCK **100000**

REAR WING

① LOW
 ② MEDIUM
 ③ HIGH

REAR HEIGHT

-3 MM. -2 MM. -1 MM. 0 MM. +1 MM. +2 MM. +3 MM.

HEIGHT ADJUST.

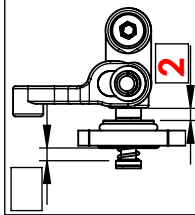

VIEW FROM TOP

CASTER

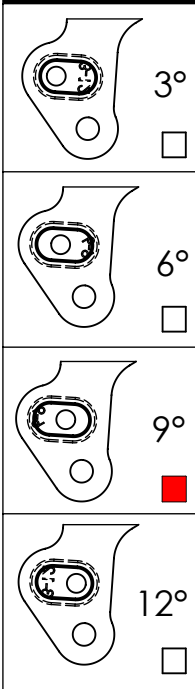

ACKERMANN

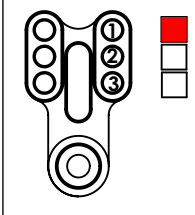

ABSORBER

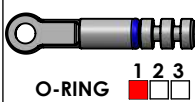

1° OUT IN TOE IN OUT 1°

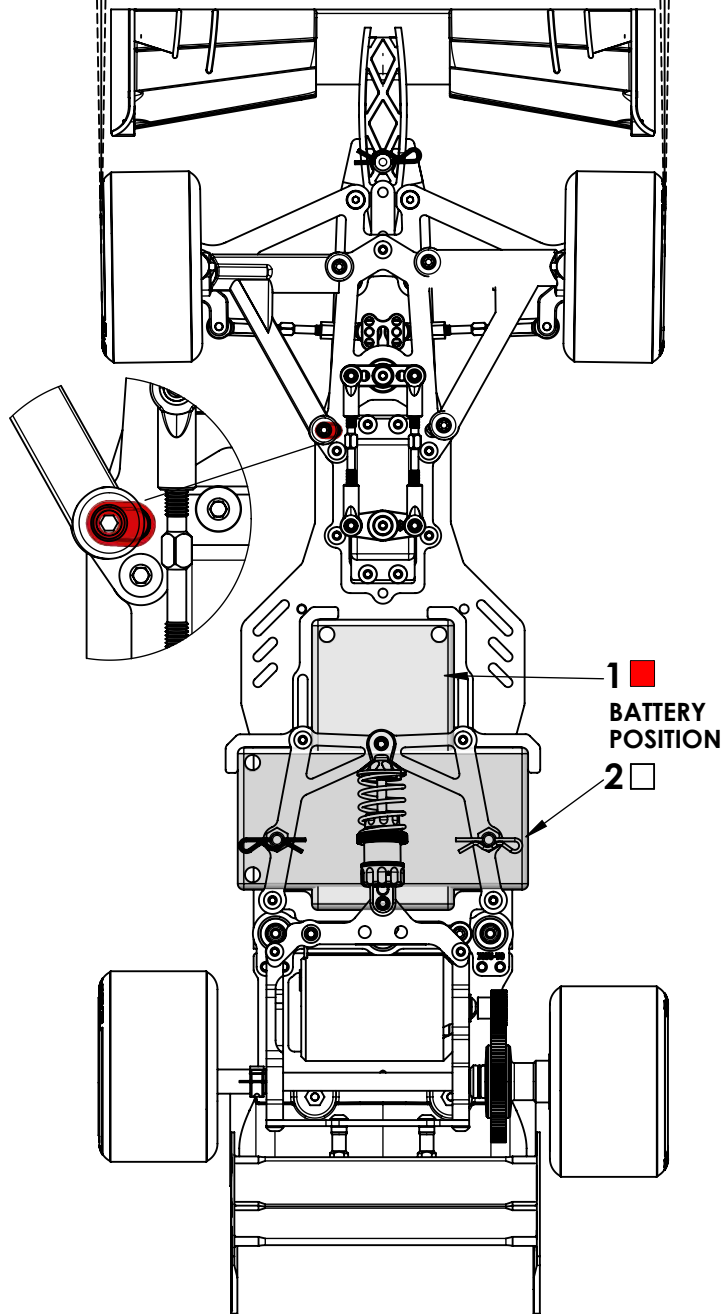

1.5 + - FRONT CAMBER - + 1.5

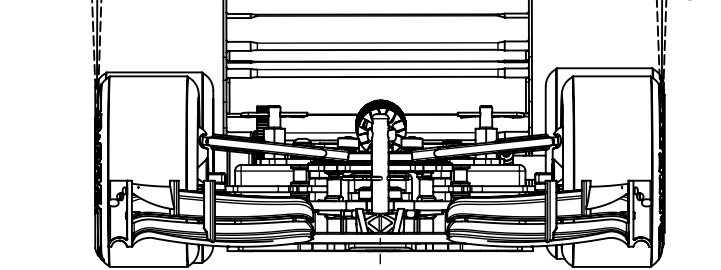

REAR WING POSITION

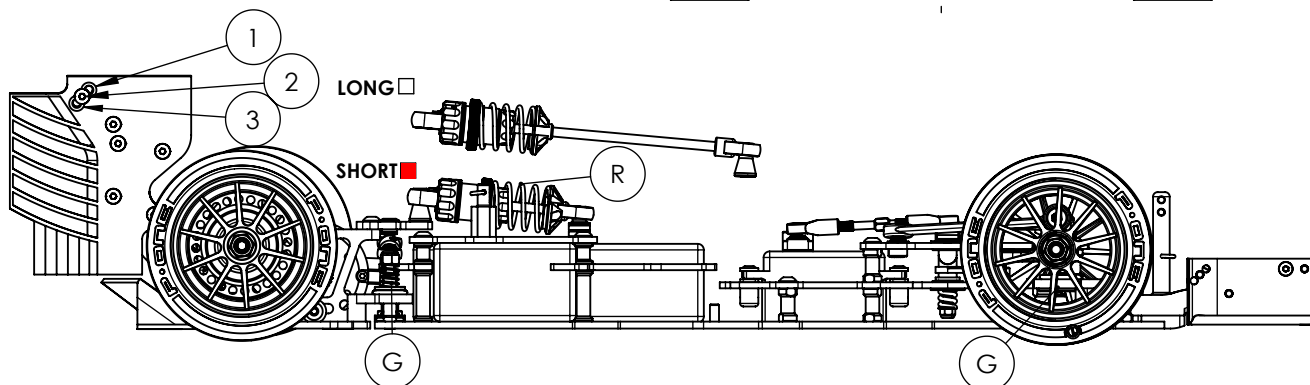
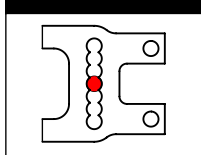



W.R.C. world racing car s.r.l.

Via Meucci, 23/B 36040 Brendola (VI) - ITALY - commerciale@wrc-racing.com

www.wrc-racing.com