

Split Mount Setup for Flex

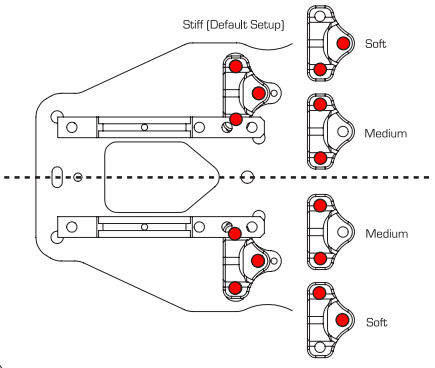

Split Mount Insert Chart

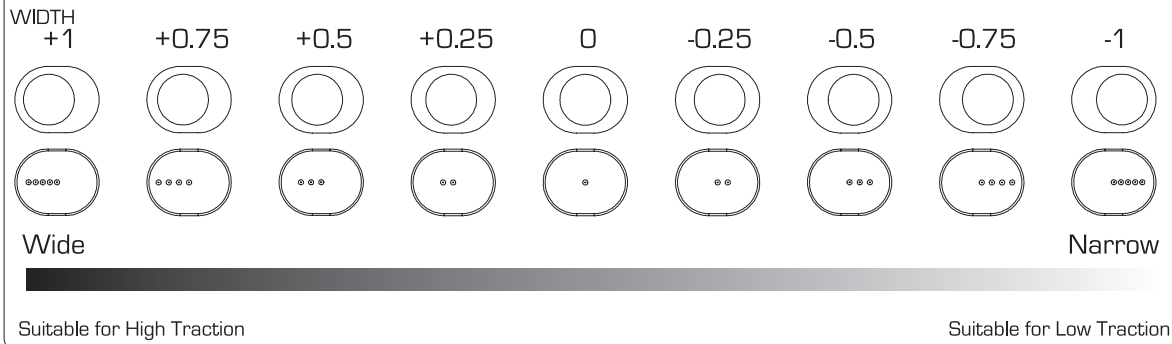

Steering Angle Setup (27Deg)

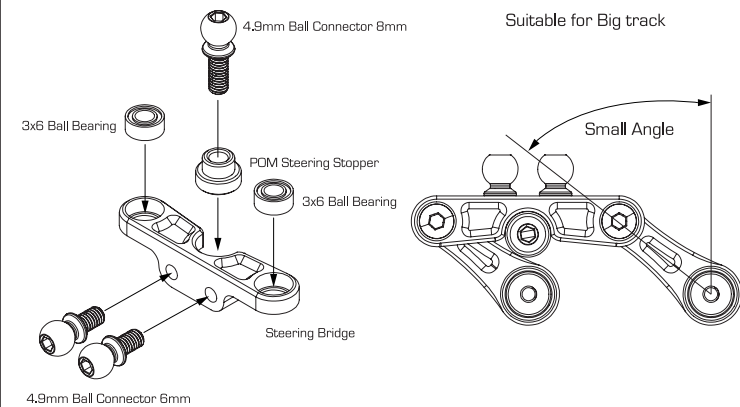

Front Suspension Mount Insert Chart

Composite Insert		Narrow	FR (Split Mount)							Wide	
			5	4	3	2	1	2	3		4
Narrow	FF (Suspension Mount)	5	0	0.25	0.5	0.75	1	1.25	1.5	1.75	2
		4	-0.25	0	0.25	0.5	0.75	1	1.25	1.5	1.75
		3	-0.5	-0.25	0	0.25	0.5	0.75	1	1.25	1.5
		2	-0.75	-0.5	-0.25	0	0.25	0.5	0.75	1	1.25
		1	-1	-0.75	-0.5	-0.25	0	0.25	0.5	0.75	1
Wide	FF (Suspension Mount)	2	-1.25	-1	-0.75	-0.5	-0.25	0	0.25	0.5	0.75
		3	-1.5	-1.25	-1	-0.75	-0.5	-0.25	0	0.25	0.5
		4	-1.75	-1.5	-1.25	-1	-0.75	-0.5	-0.25	0	0.25
		5	-2	-1.75	-1.5	-1.25	-1	-0.75	-0.5	-0.25	0

Steering Angle Setup (31Deg)

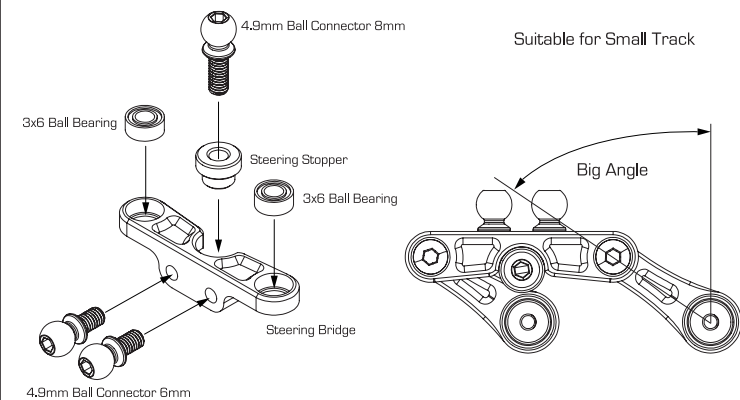

Rear Suspension Mount Insert Chart

Composite Insert		Narrow	RF (Split Mount)							Wide	
			5	4	3	2	1	2	3		4
Narrow	RR (Suspension Mount)	5	2	1.75	1.5	1.25	1	0.75	0.5	0.25	0
		4	2.25	2	1.75	1.5	1.25	1	0.75	0.5	0.25
		3	2.5	2.25	2	1.75	1.5	1.25	1	0.75	0.5
		2	2.75	2.5	2.25	2	1.75	1.5	1.25	1	0.75
		1	3	2.75	2.5	2.25	2	1.75	1.5	1.25	1
Wide	RR (Suspension Mount)	2	3.25	3	2.75	2.5	2.25	2	1.75	1.5	1.25
		3	3.5	3.25	3	2.75	2.5	2.25	2	1.75	1.5
		4	3.75	3.5	3.25	3	2.75	2.5	2.25	2	1.75
		5	4	3.75	3.5	3.25	3	2.75	2.5	2.25	2