

WILDFIRE DOB

1/10 4WD ELECTRIC COMPETITION TOURING CAR KIT

SETUP SHEET

Arr0



DRIVER _____ DATE _____

TRACK _____ RESULT _____

ASPHALT / CARPET INDOOR / OUTDOOR BEST LAP _____

HUMIDITY _____ TRACK TEMP _____ AIR TEMP _____

GRIP LOW MEDIUM HIGH SURFACE BUMPY MEDIUM SMOOTH _____

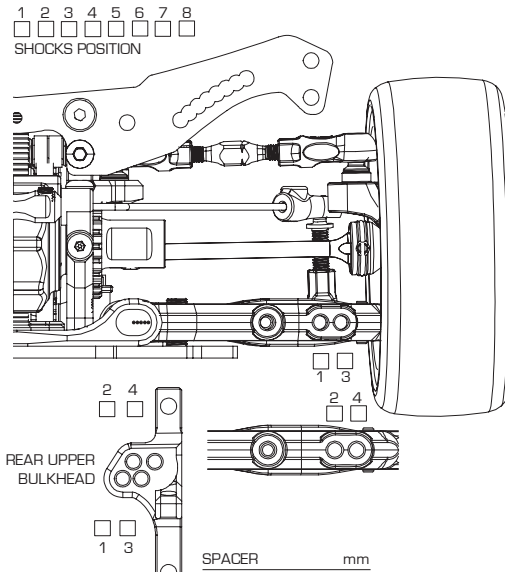
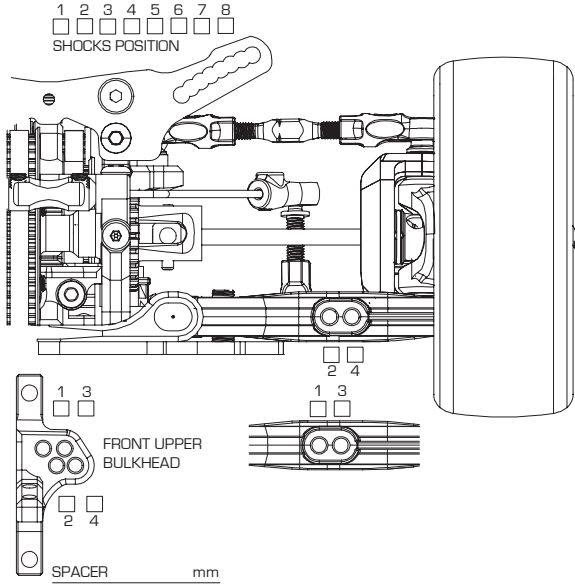

COMPOSITES

SILVER GOLD

SILVER GOLD

SILVER GOLD

SILVER GOLD

SILVER GOLD

SILVER GOLD

FRONT

GROUND CLEARANCE _____ mm DROOP _____ mm

CAMBER ANGLE _____ ° TOE ANGLE _____ °

CASTER ANGLE _____ ° FRONT DRIVE DIFF (OIL _____) / DIRECT

STABILIZER 1.2 1.3 1.4 WHEEL SPACER _____ mm

SUSPENSION SHIM (FF) _____ mm SUSPENSION SHIM (FR) _____ mm

SUSPENSION MOUNT (FF) _____ SUSPENSION MOUNT (FR) _____

AXLE TYPE / SIZE TWO-PIECE JOINT / SINGLE JOINT (STEEL / ALUM) _____ mm

REAR

GROUND CLEARANCE _____ mm DROOP _____ mm

CAMBER ANGLE _____ ° TOE ANGLE _____ °

REAR DRIVE DIFF (OIL _____) DRIVE CUP ALUMINUM / STEEL

STABILIZER 1.2 1.3 1.4 WHEEL SPACER _____ mm

SUSPENSION SHIM (FF) _____ mm SUSPENSION SHIM (FR) _____ mm

SUSPENSION MOUNT (FF) _____ SUSPENSION MOUNT (FR) _____

AXLE TYPE / SIZE TWO-PIECE JOINT / SINGLE JOINT (STEEL / ALUM) _____ mm

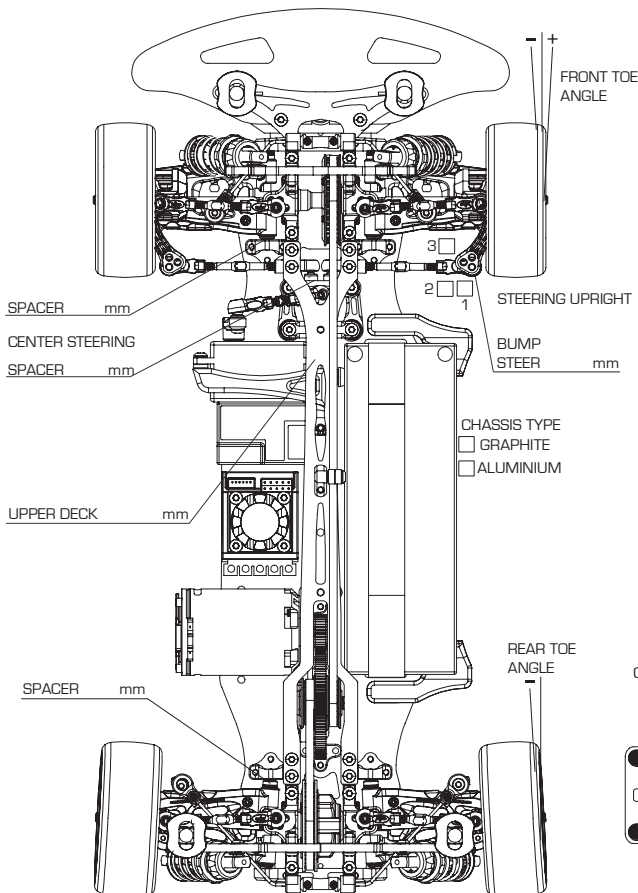

FRONT

SHOCK LENGTH _____ mm

PISTON 3 4 hole(s) / OTHERS _____

OIL _____

SPRING _____

OIL SEALER CAP S / MS / M / H _____

REBOUND _____ %

NOTES _____

REAR

SHOCK LENGTH _____ mm

PISTON 3 4 hole(s) / OTHERS _____

OIL _____

SPRING _____

OIL SEALER CAP S / MS / M / H _____

REBOUND _____ %

NOTES _____

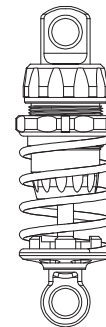

MOTOR _____ SPUR _____ T _____ PITCH _____ PINION _____ T _____

TIRE _____ TIRE INSERT _____ WHEEL _____

TIRE ADDITIVE _____ BODY _____ REAR WING _____

ESC _____ BATTERY _____

REMARKS _____

Chassis Flex Setting (Fill in the Circle)

