

WILDFIRE DOB

1/10 4WD ELECTRIC COMPETITION TOURING CAR KIT

SETUP SHEET

Am0 **vbc racing**

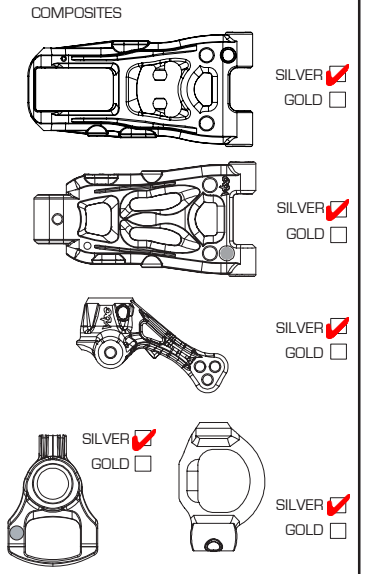
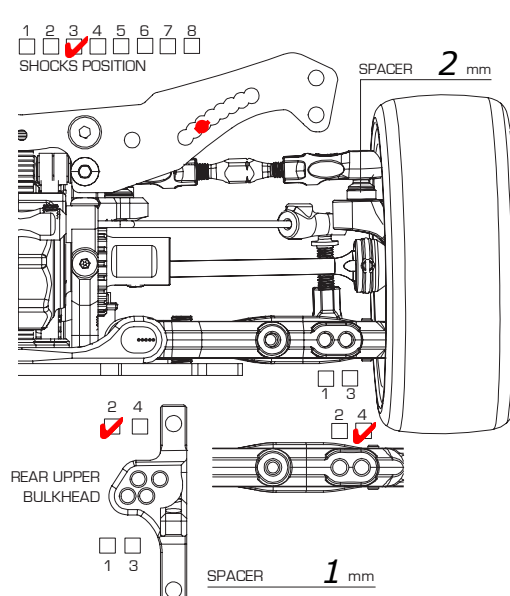
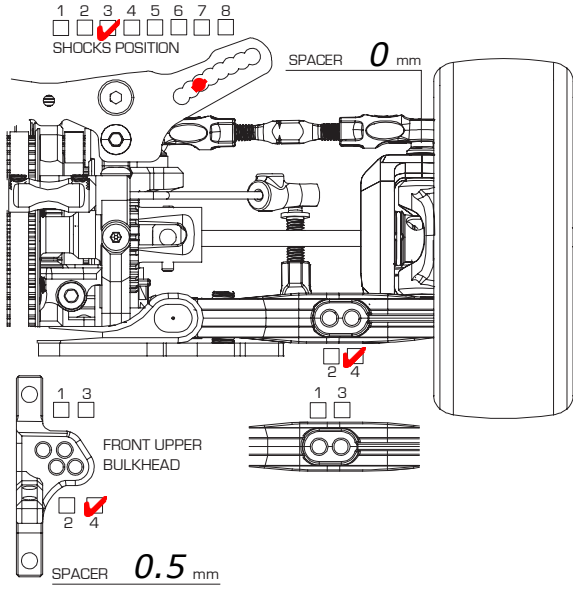

FRONT

GROUND CLEARANCE **5.2** mm DROOP **5.5** under a mm

CAMBER ANGLE **1,5**° TOE ANGLE **1**°

CASTER ANGLE **4**° FRONT DRIVE DIFF (OIL) / DIRECT

STABILIZER 1.2 1.4 WHEEL SPACER mm

SUSPENSION SHIM (FF) **0.5** mm SUSPENSION SHIM (FR) **0.5** mm

SUSPENSION MOUNT (FF) **1** SUSPENSION MOUNT (FR) **+2**

AXLE TYPE / SIZE TWO-PIECE JOINT / SINGLE JOINT (STEEL/ALUM) mm

REAR

GROUND CLEARANCE **5.4** mm DROOP **0.5** mm

CAMBER ANGLE **1,5**° TOE ANGLE **2.25**°

REAR DRIVE DIFF (OIL **10K**) DRIVE CUP ALUMINUM / STEEL

STABILIZER 1.2 1.4 WHEEL SPACER mm

SUSPENSION SHIM (FF) **0.5** mm SUSPENSION SHIM (FR) **0.5** mm

SUSPENSION MOUNT (FF) **-3** SUSPENSION MOUNT (FR) **-2**

AXLE TYPE / SIZE TWO-PIECE JOINT / SINGLE JOINT (STEEL/ALUM) **49** mm

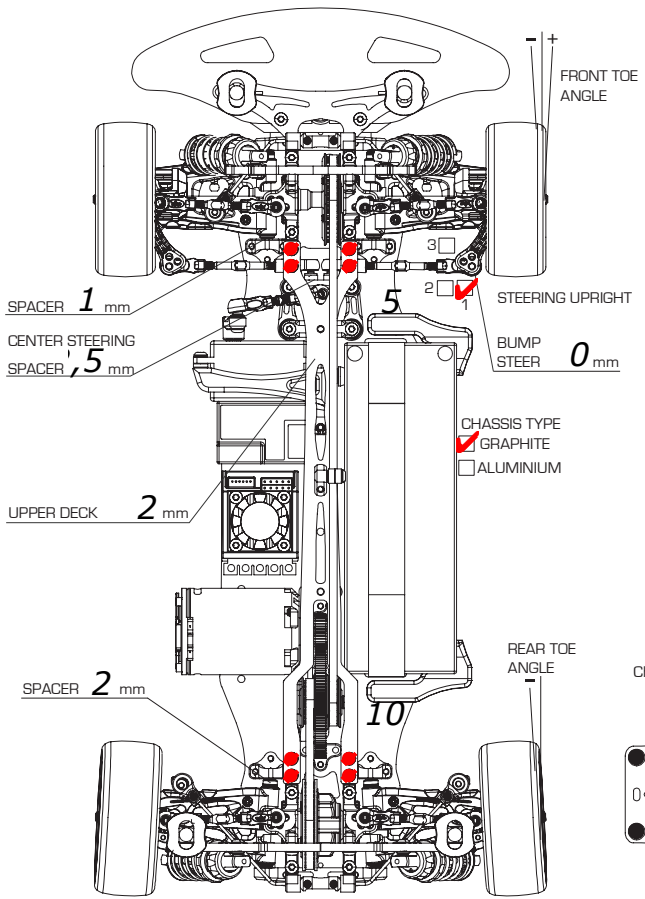

FRONT

SHOCK LENGTH **10.5** mm

PISTON 3 4 hole(s) / OTHERS **PSS**

OIL **500**

SPRING **2.5-2.8**

OIL SEALER CAP S / M / H

REBOUND **10** %

NOTES **no hole on cap**

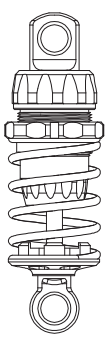

REAR

SHOCK LENGTH **10.5** mm

PISTON 3 4 hole(s) / OTHERS **PSS**

OIL **500**

SPRING **2.7**

OIL SEALER CAP S / M / H

REBOUND **10** %

NOTES

MOTOR **PRT** SPUR **108** T PITCH **34** PINION T

TIRE **volante 36** TIRE INSERT WHEEL

TIRE ADDITIVE **carpet 2** BODY **nazda 2** REAR WING

ESC **v3.1** BATTERY **IP**

REMARKS **cut the middle of top deck**

