

WILDFIRE DOB

1/10 4WD ELECTRIC COMPETITION TOURING CAR KIT

SETUP SHEET

Arr0



DRIVER _____ DATE _____

TRACK _____ RESULT _____

ASPHALT / CARPET INDOOR / OUTDOOR BEST LAP _____

HUMIDITY _____ TRACK TEMP _____ AIR TEMP _____

GRIP LOW MEDIUM HIGH SURFACE BUMPY MEDIUM SMOOTH _____

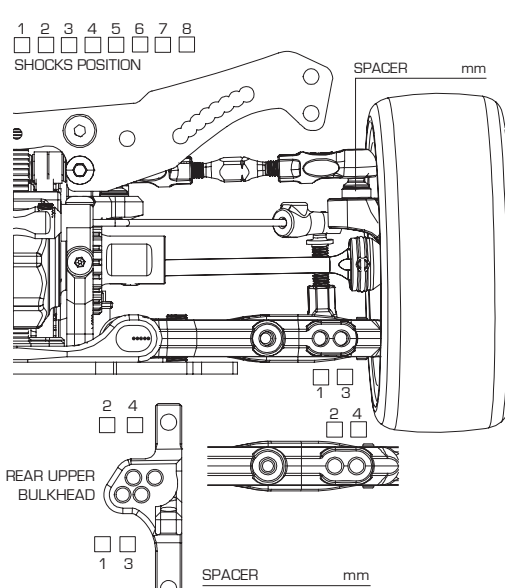
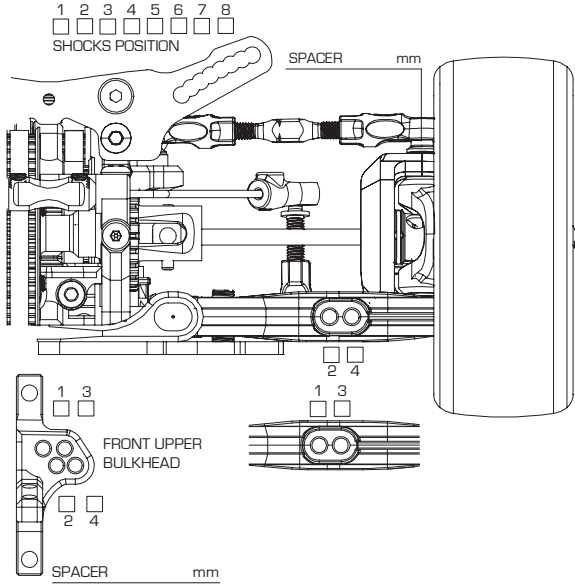

COMPOSITES

SILVER
GOLD

SILVER
GOLD

SILVER
GOLD

SILVER
GOLD

SILVER
GOLD

FRONT

GROUND CLEARANCE mm DROOP mm

CAMBER ANGLE ° TOE ANGLE °

CASTER ANGLE ° FRONT DRIVE DIFF (OIL) / DIRECT

STABILIZER 1.2 1.3 1.4 WHEEL SPACER mm

SUSPENSION SHIM (FF) mm SUSPENSION SHIM (FR) mm

SUSPENSION MOUNT (FF) SUSPENSION MOUNT (FR)

AXLE TYPE / SIZE TWO-PIECE JOINT / SINGLE JOINT (STEEL / ALUM) mm

REAR

GROUND CLEARANCE mm DROOP mm

CAMBER ANGLE ° TOE ANGLE °

REAR DRIVE DIFF (OIL) DRIVE CUP ALUMINUM / STEEL

STABILIZER 1.2 1.3 1.4 WHEEL SPACER mm

SUSPENSION SHIM (FF) mm SUSPENSION SHIM (FR) mm

SUSPENSION MOUNT (FF) SUSPENSION MOUNT (FR)

AXLE TYPE / SIZE TWO-PIECE JOINT / SINGLE JOINT (STEEL / ALUM) mm

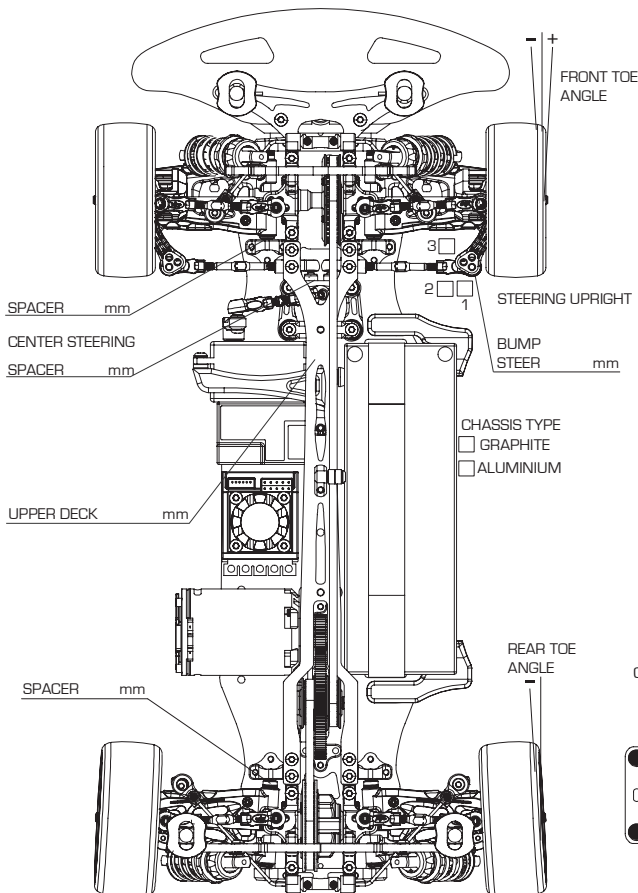

FRONT

SHOCK LENGTH mm

PISTON 3 4 hole(s) / OTHERS

OIL

SPRING

OIL SEALER CAP S / MS / M / H

REBOUND %

NOTES



REAR

SHOCK LENGTH mm

PISTON 3 4 hole(s) / OTHERS

OIL

SPRING

OIL SEALER CAP S / MS / M / H

REBOUND %

NOTES

MOTOR SPUR T PITCH PINION T

TIRE TIRE INSERT WHEEL

TIRE ADDITIVE BODY REAR WING

ESC BATTERY

REMARKS

Chassis Flex Setting (Fill in the Circle)

