

COMPETITION GRADE HIGH PERFORMANCE RADIO CONTROL RACING CAR CHASSIS KIT

WILDFIRE DOT

1/10 4WD ELECTRIC COMPETITION TOURING CAR KIT

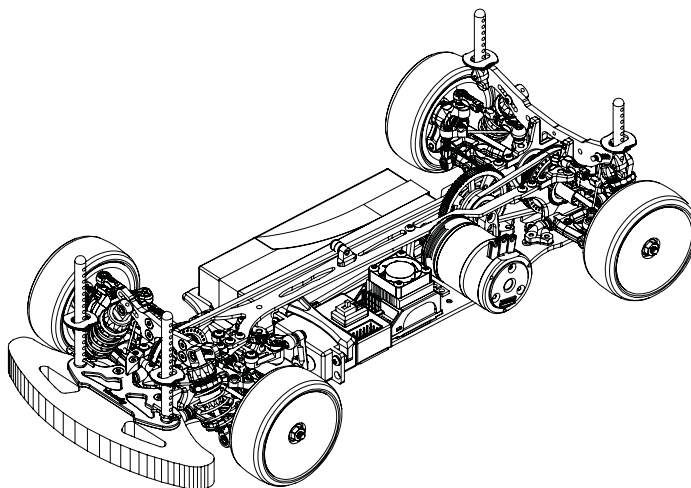

INSTRUCTIONS MANUAL

vbc racing

E

Thank you for purchasing VBC Racing product.

Things that we should remind you.

This VBC Racing kit is a high performance, racing grade car kit intended for experienced racers. The kit compose of VBC formulated composite materials, top quality full carbon fiber chassis and high grade 7075 material which will give you a competitive edge over the others.

Novice racer should seek advice from more experienced racer before assembly.

Always keep this instruction manual handy at all times for quick reference even after completing the assembly.

Before your assembly, sand the chassis edges.

Sand the chassis edges with #600 sand paper and apply CA glue to the edges and counter sink holes.

Need help or support.

If you need help or you would like to leave us a comment, please email to our support team: support@vbc-racing.com or visit our web site www.vbc-racing.com



1

Graphite Edges Protection Procedure



*Not included in this kit

Sand the chassis edges with #600 sand paper(not included) and apply CA glue(not included) to the edges of the chassis.

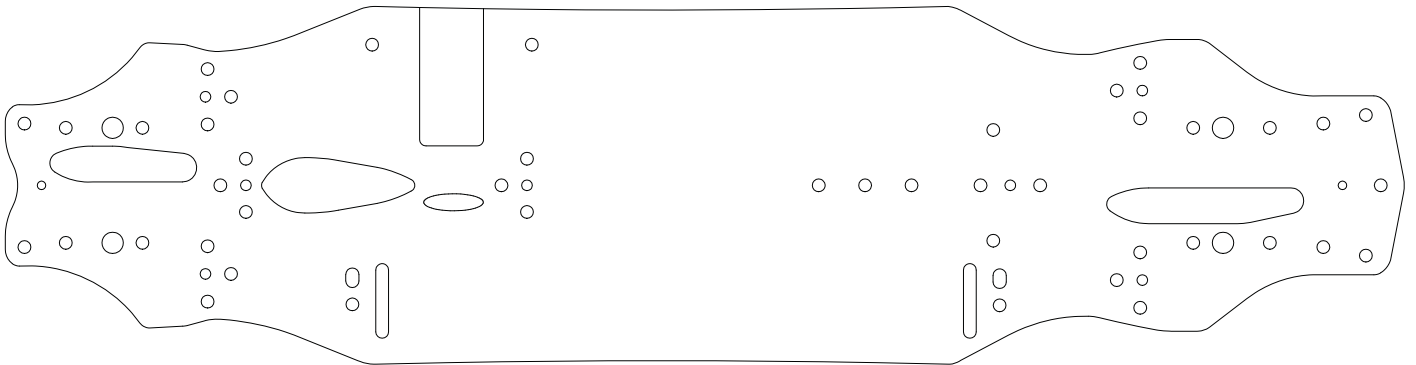

A-01-P30167 WildFireD07 Standard Graphite Chassis

Sand the below graphite edges with #600 sand paper and apply CA glue to the edges.

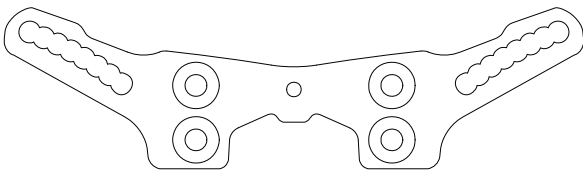

A-01-P30246 WildFireD07 Graphite Front Shock Tower

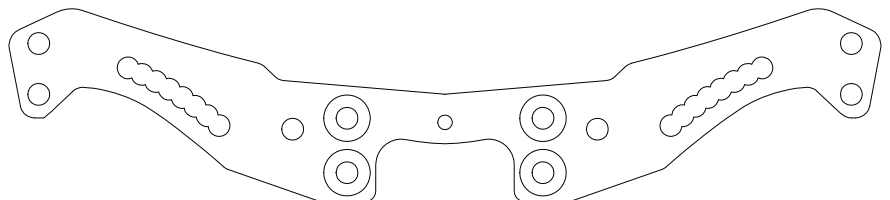

A-01-P30247 WildFireD07 Graphite Rear Shock Tower

2

Rear Gear Diff Assembly

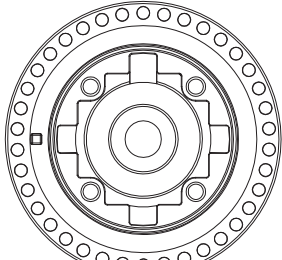

Gear Diff Housing A-03-VBC-0016 x 1

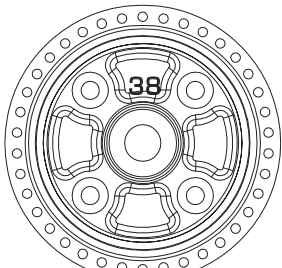

Gear Diff Pulley 38T A-03-VBC-0017 x 1

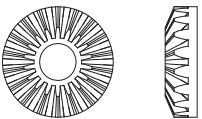

Diff Gear 18T A-03-VBC-0019 x 2



Diff Cup B-02-VBC-0022 x 2

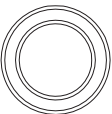

10x15 Ball Bearing C-02-BB-1510-P x 2

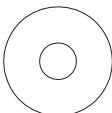

15x0.3 Shim B-02-VBC-0077 x 2



M2x10 Shaft Pin B-02-VBC-0020 x 2



Diff Shaft Sealer O-Ring B-03-VBC-0006 x 2

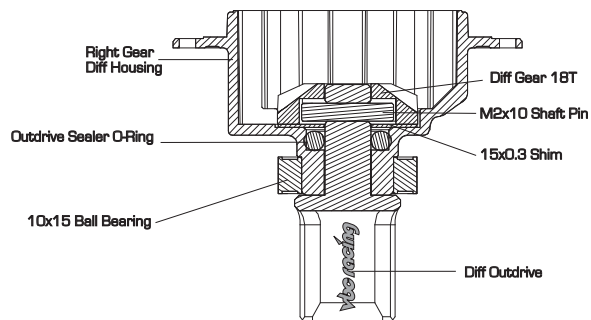
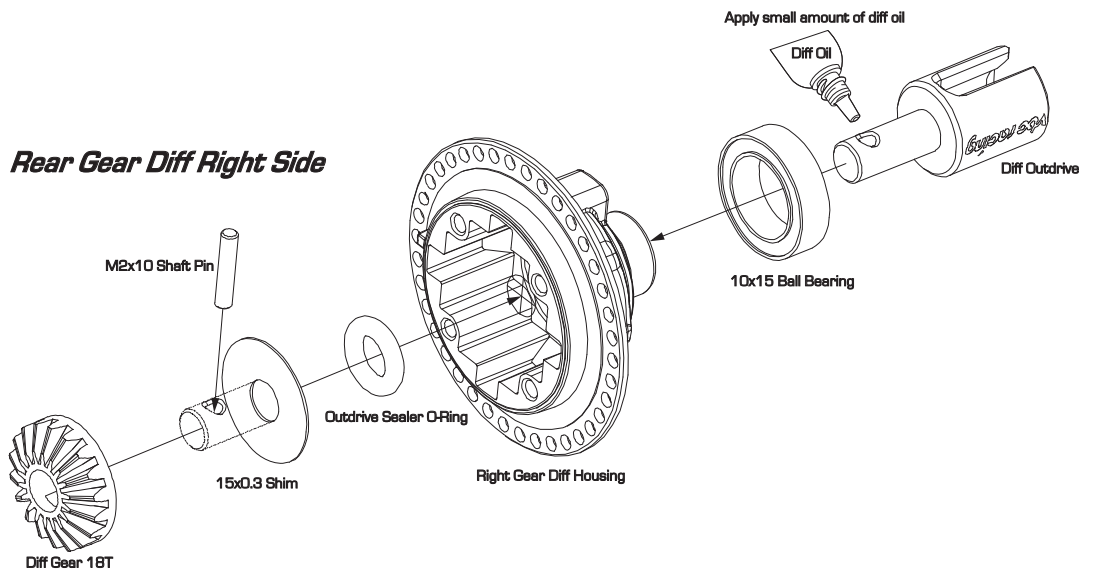
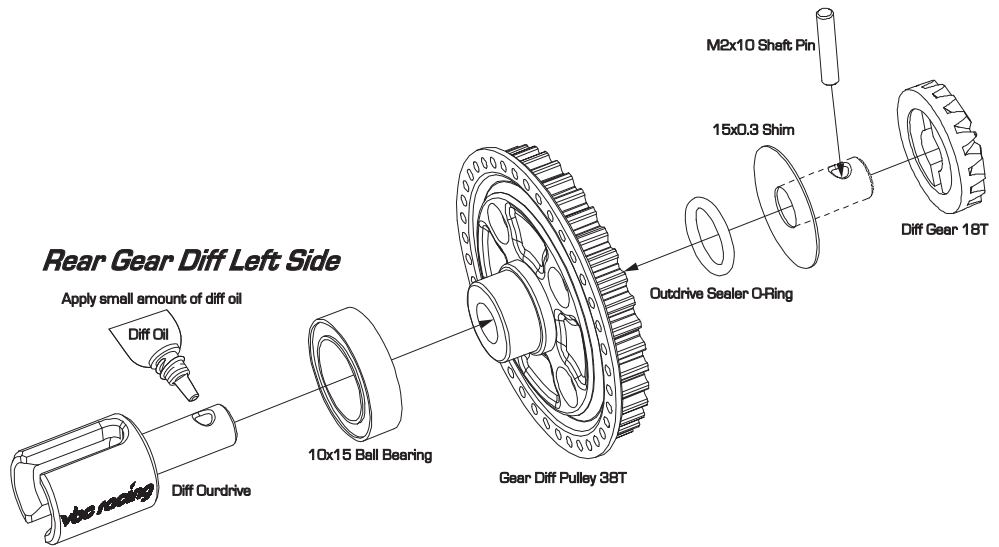

3

Rear Gear Diff Assembly Continue

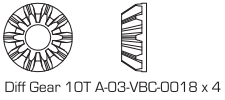

Diff Gear 10T A-03-VBC-0018 x 4



9.5x0.2mm Shim B-02-VBC-0078 x 4



M2.6x10 Flathead Screw C-02-SC-F2.6x10 x 4

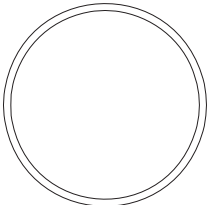

Diff Housing Sealer O-Ring B-03-VBC-0005 x 1

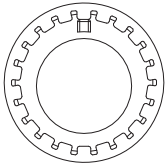

Belt Tension Adjuster Ring A-03-VBC-0047 x 2

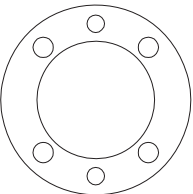

Seal Gasket B-03-VBC-0004 x 1

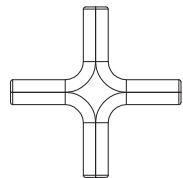

Diff Gear Shaft A-03-VBC-0020 x 1

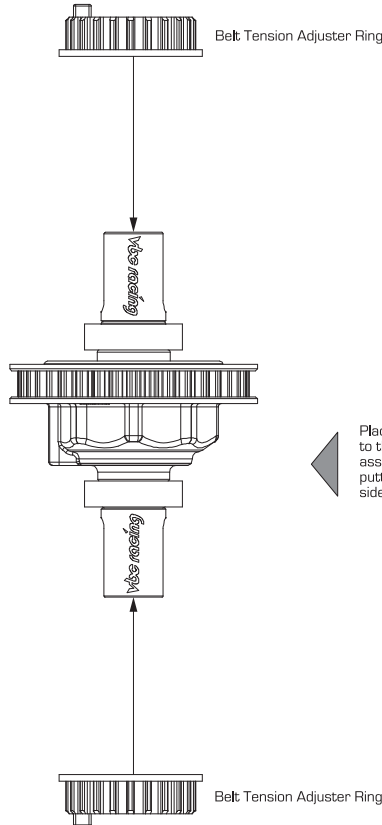
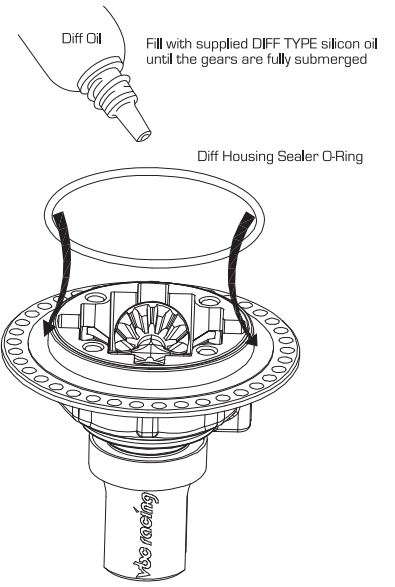
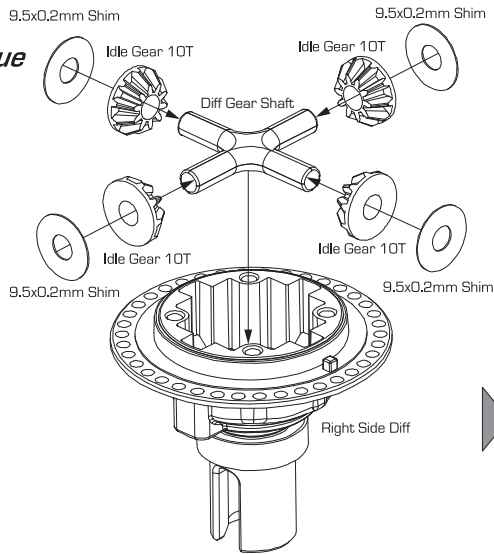

Place Seal Gasket to the left side diff assembly before putting the right side diff together

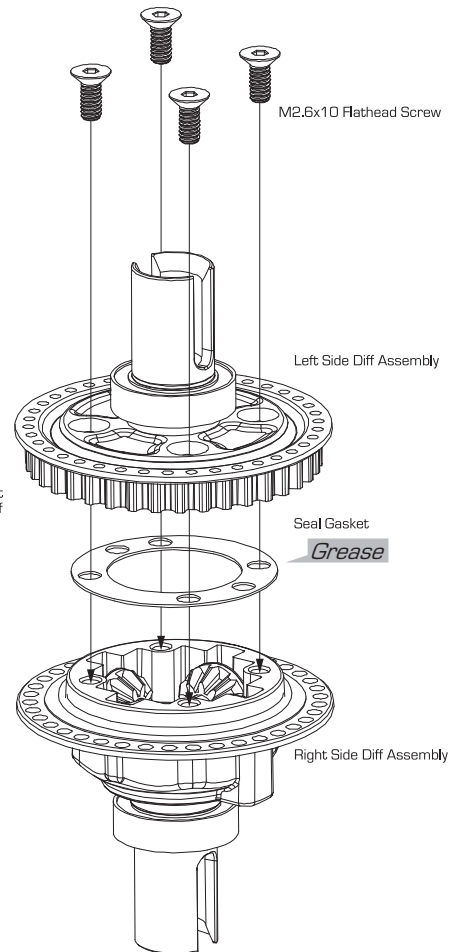

Please Note The "RL" & "RR"
Markings Directions During
Assembly

Optional WildFireD07 Split Mounts

4

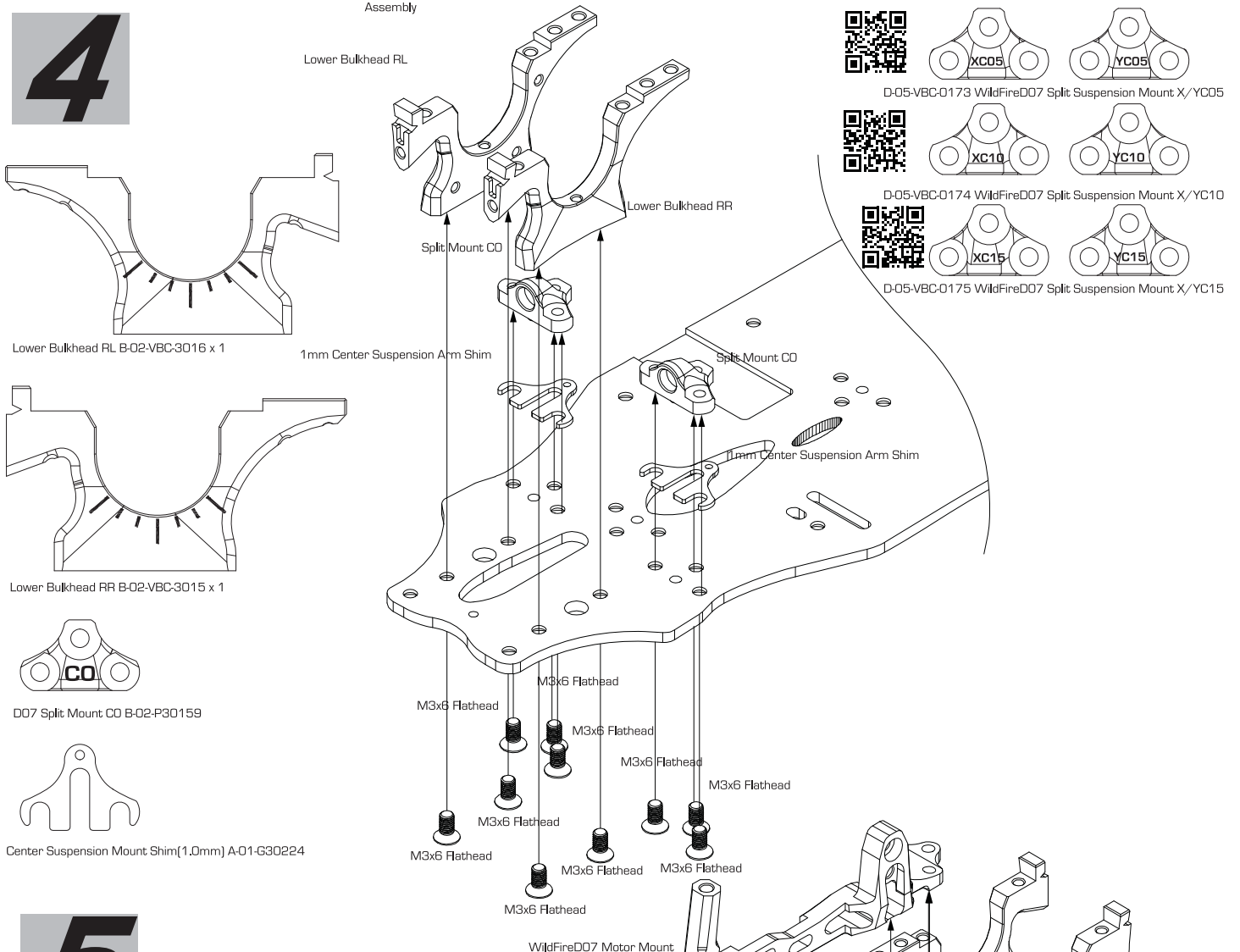

Lower Bulkhead RL B-02-VBC-3016 x 1

1mm Center Suspension Arm Shim

Lower Bulkhead RR B-02-VBC-3015 x 1

D07 Split Mount CO B-02-P30159

Center Suspension Mount Shim(1.0mm) A-01-G30224

5

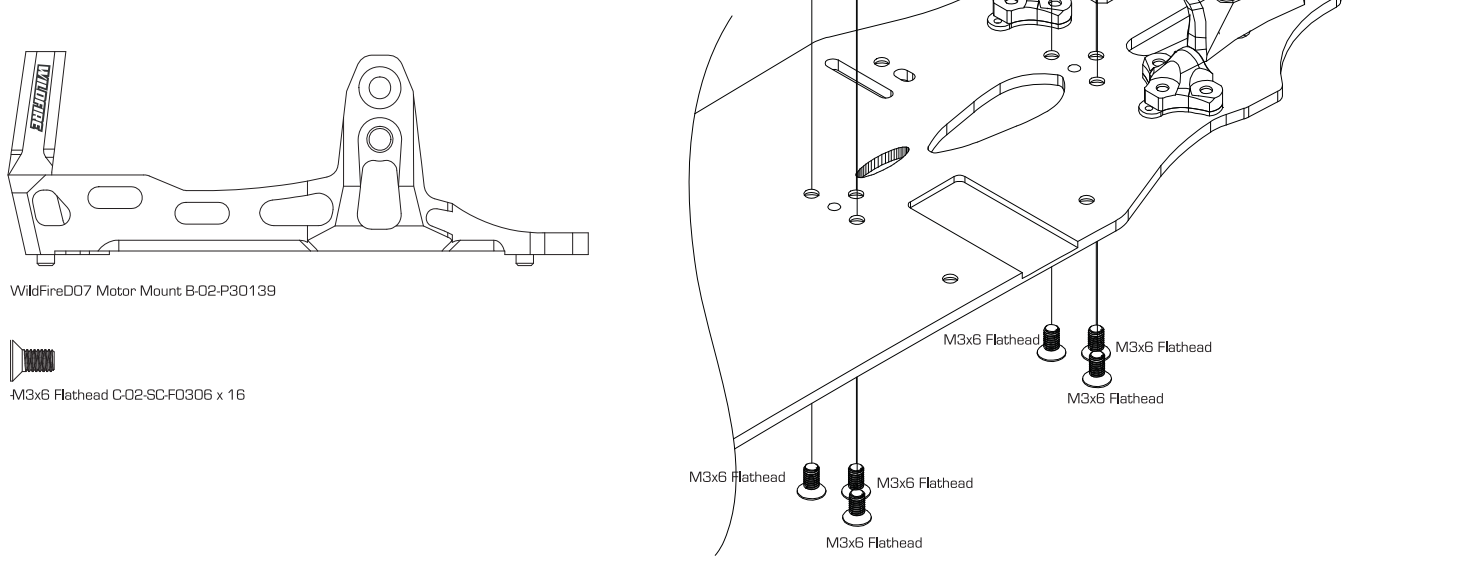

WildFireD07 Motor Mount B-02-P30139

M3x6 Flathead C-02-SC-F0306 x 16

6

Front Drive Train Assembly

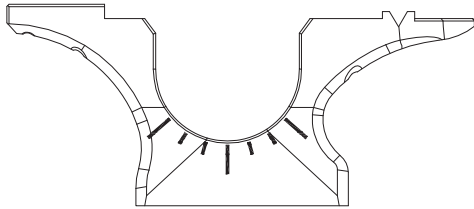

Lower Bulkhead FR B-02-VBC-3013 x 1

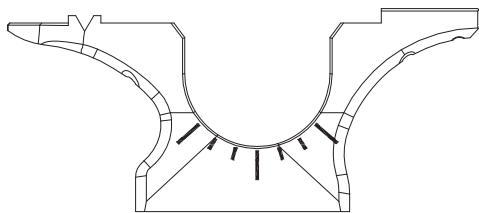

Lower Bulkhead FL B-02-VBC-3014 x 1

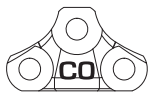

D07 Split Mount CO B-02-P30159



Center Suspension Mount Shim[1.0mm] A-01-G30224



M3x6 Flathead C-02-SC-F0306 x 8

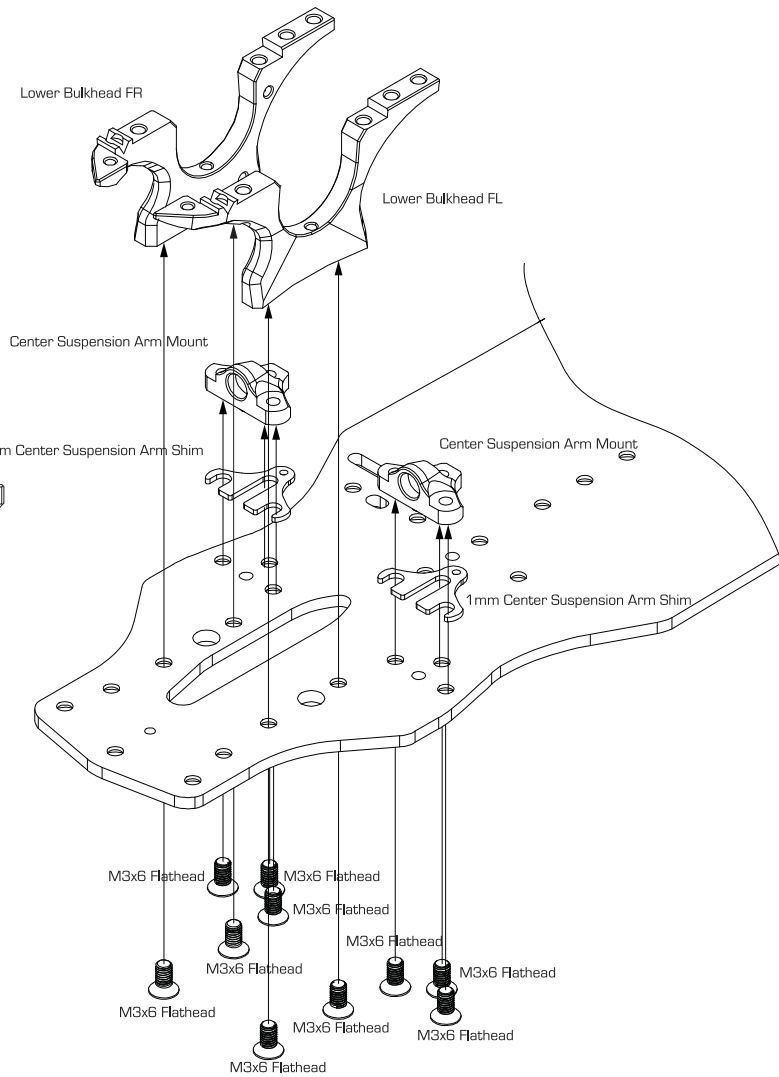

Optional WildFireD07 Split Mounts

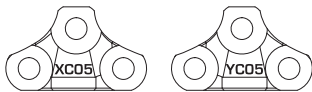

D-05-VBC-0173 WildFireD07 Split Suspension Mount X/YC05

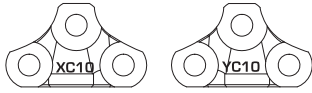

D-05-VBC-0174 WildFireD07 Split Suspension Mount X/YC10

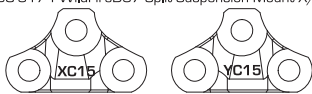

D-05-VBC-0175 WildFireD07 Split Suspension Mount X/YC15

Note the direction on front lower bulkhead FR & FL

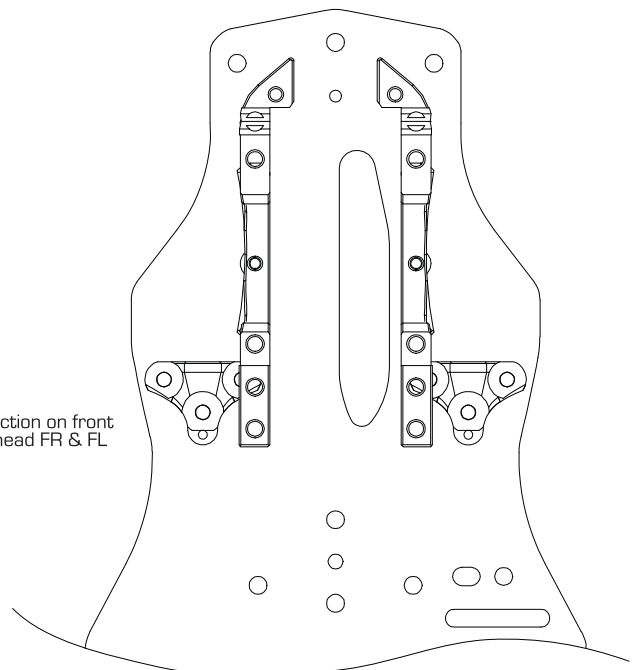

7

Floating Steering System Assembly

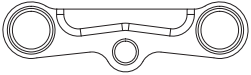

WildFireD07 Steering Bridge B-02-P30153 x 1

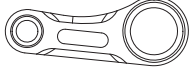

WildFireD07 Steering Arm, Left B-02-P30152 x 1



WildFireD07 Steering Arm, Right B-02-P30151 x 1



Ball Connector 4.7x12mm A-02-VBC-5015 x 2



Ball Connector (5mm Length) B-02-VBC-3021 x 1



5x8 Ball Bearing C-02-BB-0805-B x 4



3x6 Ball Bearing C-02-BB-0603 x 2



T2 7075 Spacer B-02-VBC-0019-20 x 2



M3x6 Roundhead C-02-SC-R0306 x 2



M3x8 Roundhead C-02-SC-R0308 x 2



WildFireD07 Steering Top-mounted Post B-02-P30154 x 2

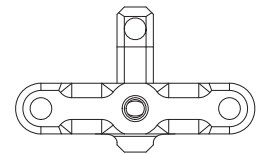

WildFireD07 Floating Steering Mount B-02-P30155 x 1



M3x42mm Turnbuckle B-02-VBC-0037 x 2



M3x18mm Turnbuckle B-02-VBC-0038 x 1

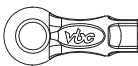

Turnbuckle Cup A-03-VBC-0039 x 4



Turnbuckle Cup (Long) A-03-VBC-5016 x 2

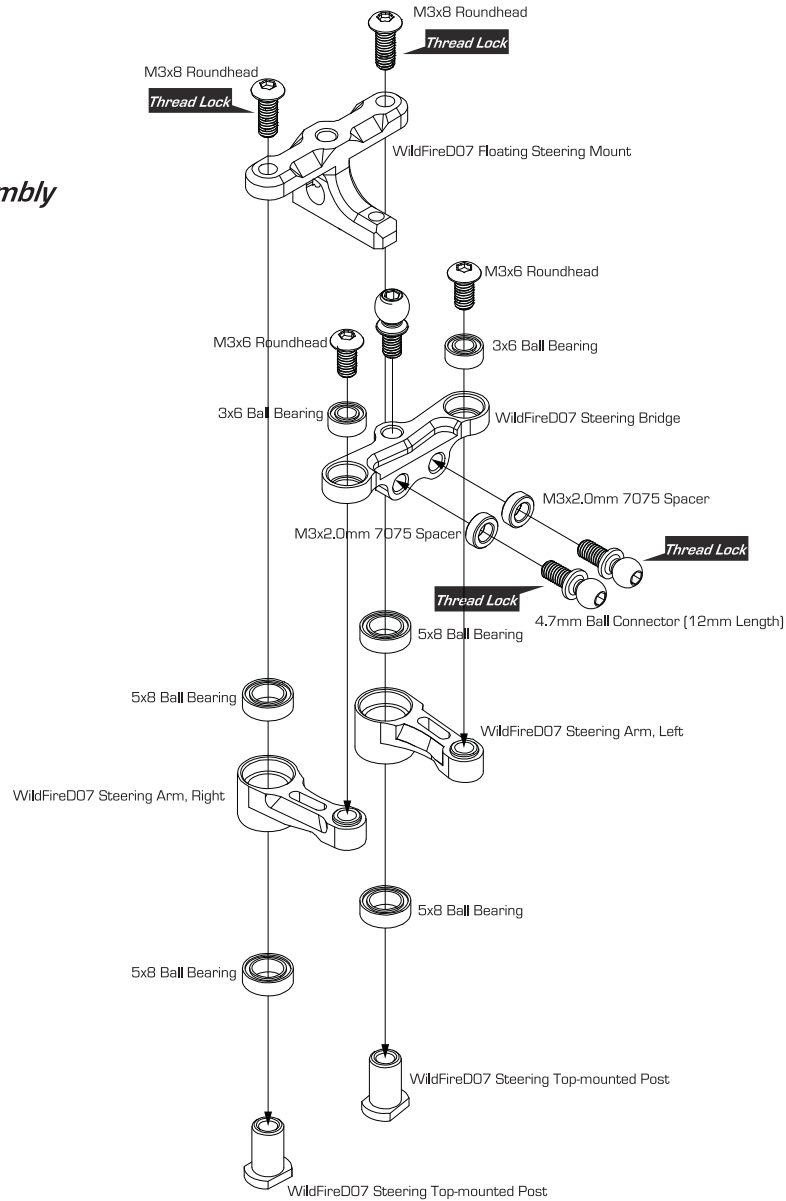

8

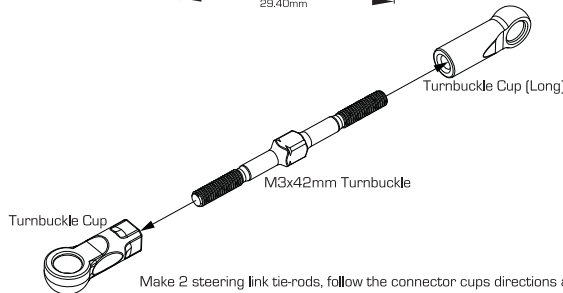
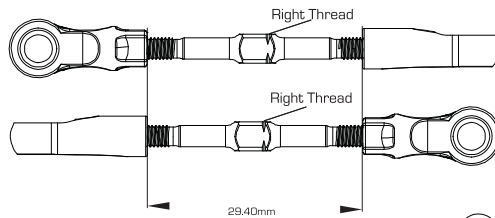

Make 2 steering link tie-rods, follow the connector cups directions as the above diagram. The connector cups edge to edge shall be 29.40mm. Please use a caliper to measure the exact measurement.

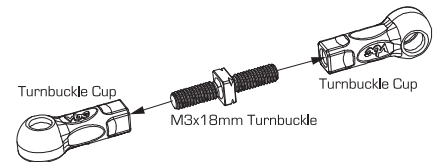
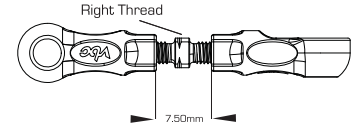

Make 1 servo link tie-rod, follow the connector cups directions as the above diagram. The connector cups edge to edge shall be 7.50mm. Please use a caliper to measure the exact measurement.

9

Steering System Assembly



M3x6 Flathead C-02-SC-F0306 x 2

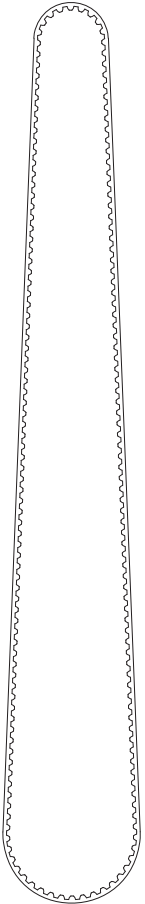

WildFireD06 Front Belt: B-03-VBC-3001 x 1

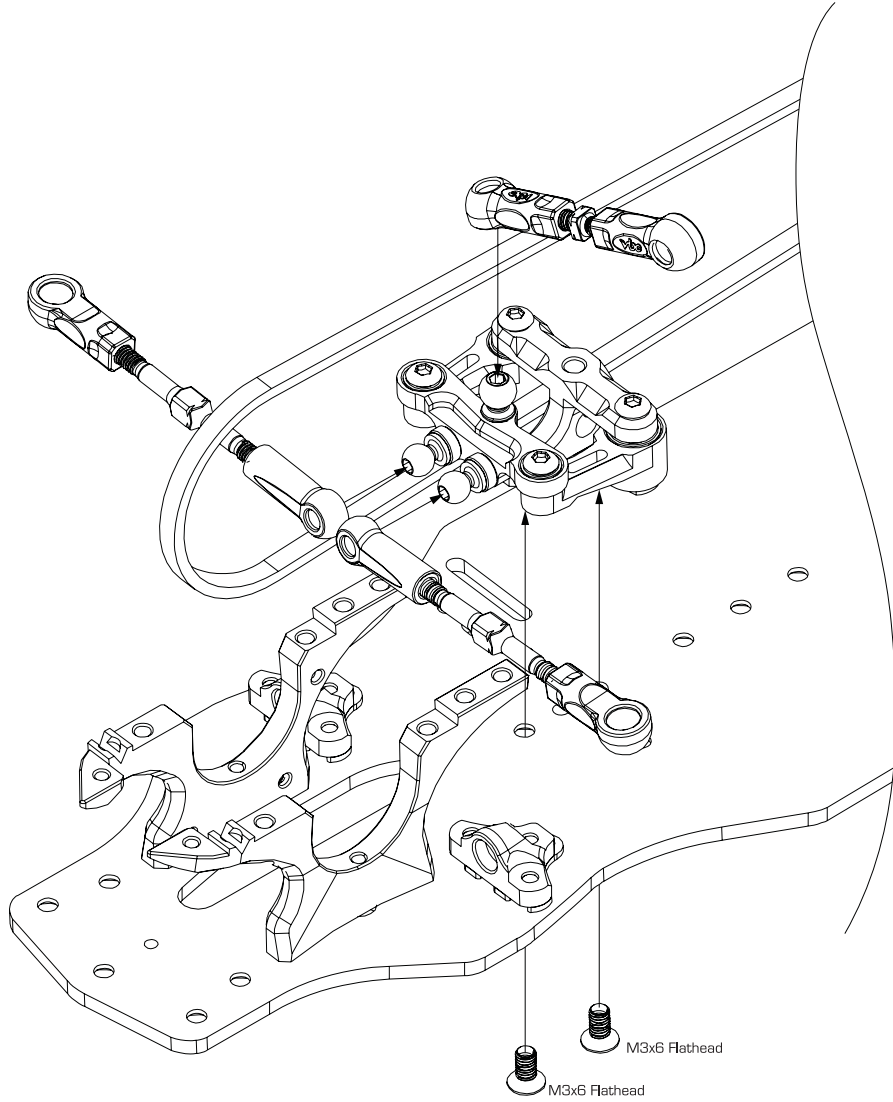

Install the steering unit onto the main chassis with two M3x6 Flathead Screws. Then attach the left and right tie rods to the steering unit. Make sure the front belt is between the two Steering Assembly Poles.

10

Upper Deck Assembly



WildFireD07 Center Belt Tensioner B-02-P30158 x 1



3x6mm Ball Bearing C-02-BB-0603 x 2



3x5x0.3mm Shim B-02-VBC-0101 x 3



M3x10 Roundhead C-02-SC-R0310 x 1



M3x6 Roundhead Screw C-02-SC-R0306 x 1

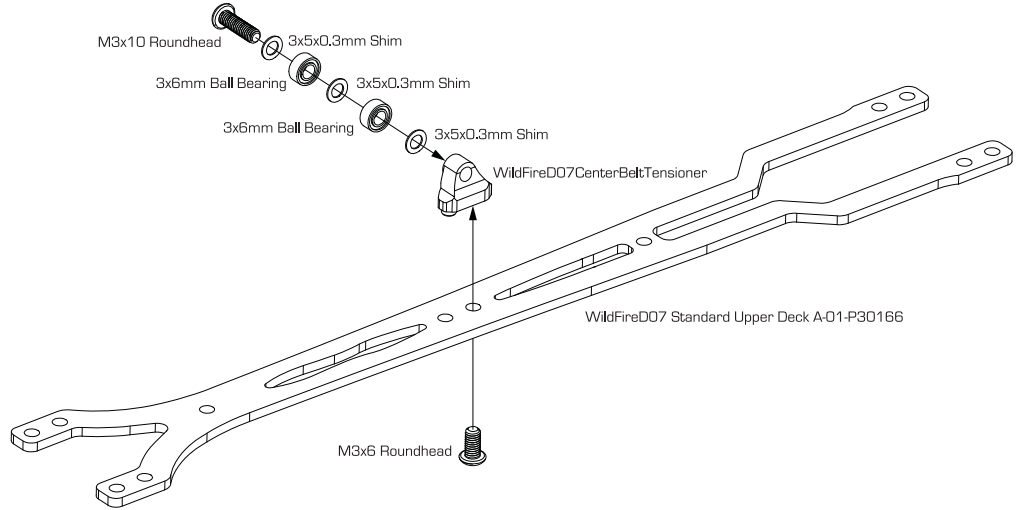

11

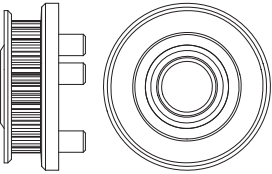

WildFireD07 Alu Center Pully Adaptor B-02-P30219 x 1

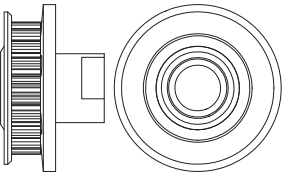

WildFireD07 Alu Spur Gear Adaptor B-02-P30220 x 1



WildFireD07 Alu Center Pully Spacer B-02-P30144 x 1



WildFireD07 Center Pully Shaft C-02-P30145 x 1



M3x4 Round Head Screw C-02-SC-R0304 x 3



5x8mm Ball Bearing C-02-BB-0805-B x 3

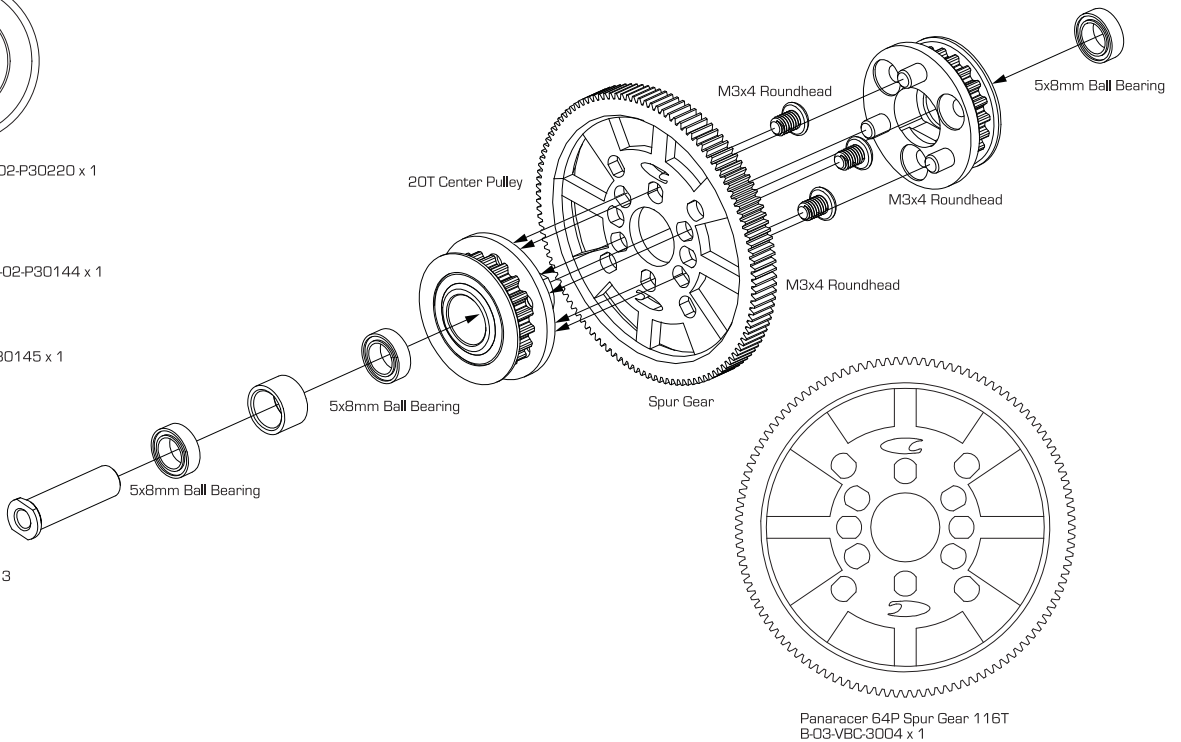

Panaracer 64P Spur Gear 116T B-03-VBC-3004 x 1

12

Upper Deck Assembly



M3x6 Roundhead C-02-SC-R0306 x 11

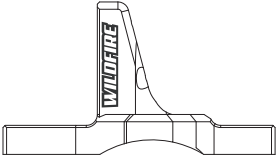

WildFireD07 Rear Upper Bulkhead, Right B-02-P30148

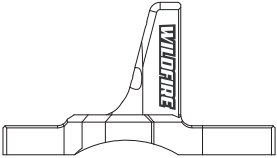

WildFireD07 Rear Upper Bulkhead, Left B-02-P30149



Ball Connector (5mm Length) B-02-VBC-3021 x 2



T2 7075 Spacer B-02-VBC-0019-20 x 2

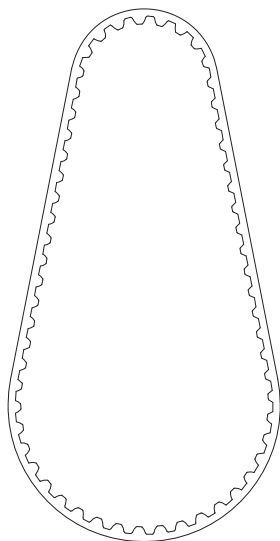
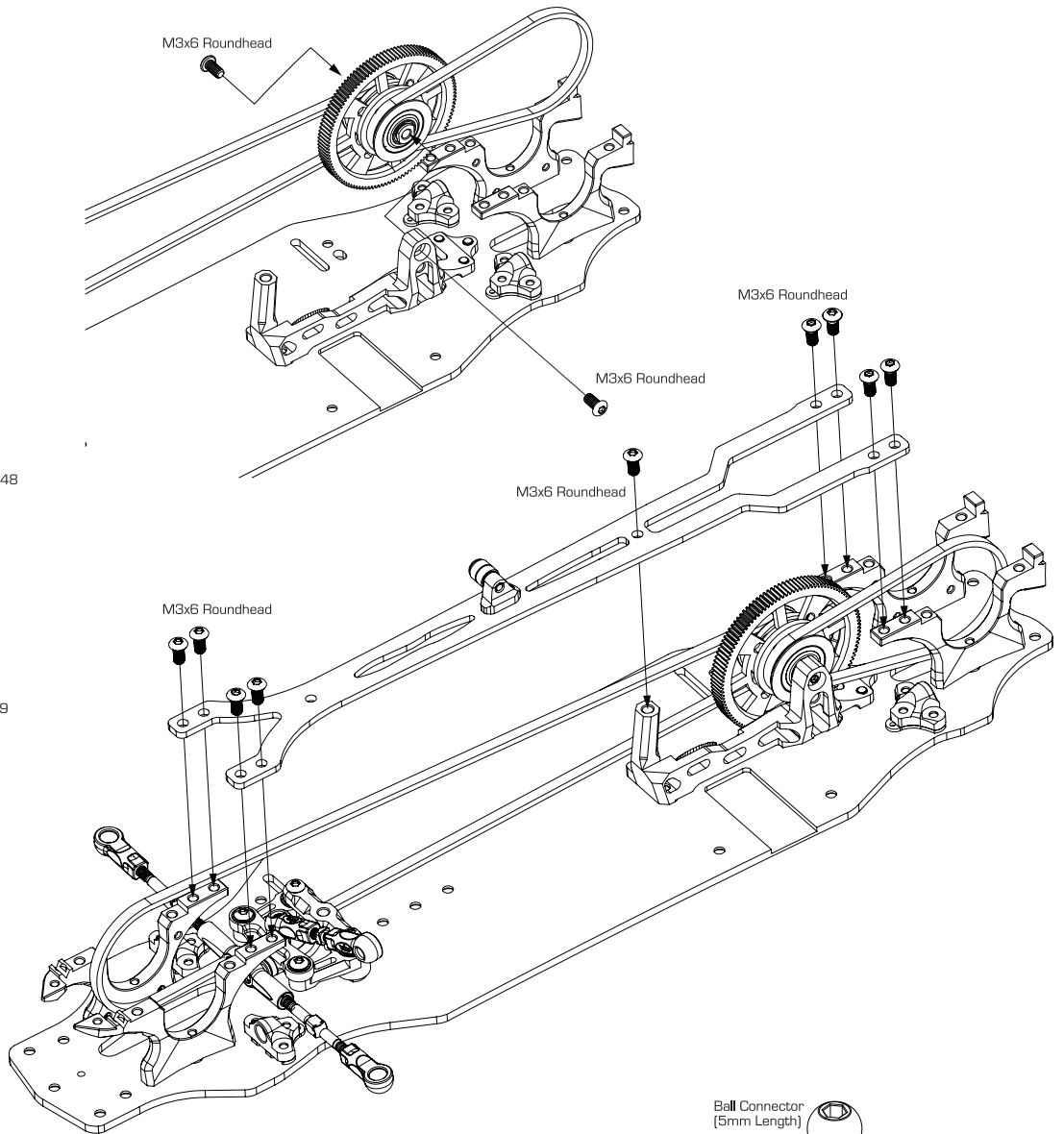

WildFire Rear Belt B-03-VBC-3002 x 1

13

Rear Upper Bulkhead Assembly

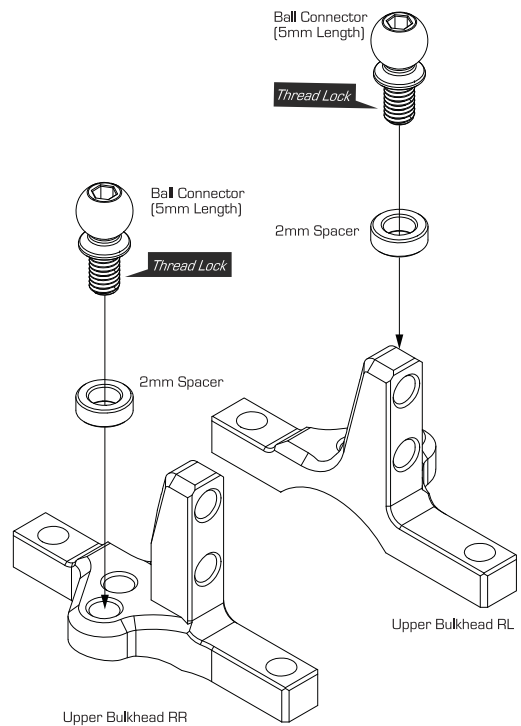

14

Install Rear Drivetrain



M3x8 Roundhead C-02-SC-R0308 x 4



M2x10 Roundhead C-02-SC-R2.0x10 x 2

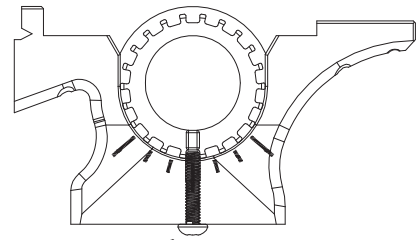
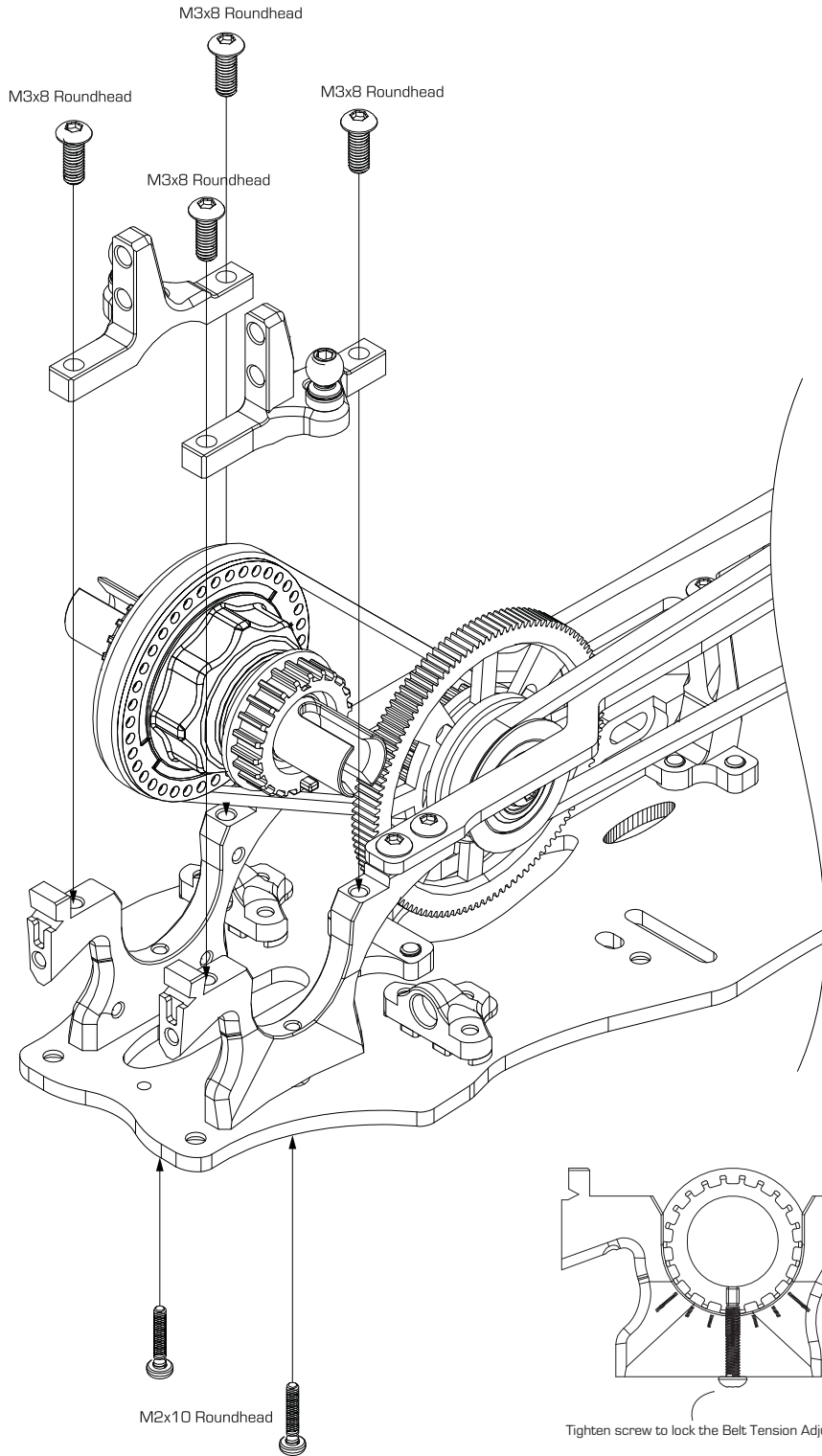

Tighten screw to lock the Belt Tension Adjuster Ring position

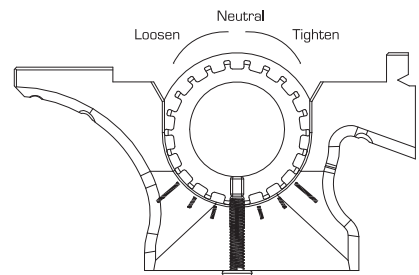

Tighten or loosen the belt tension by adjusting the Belt Tension Adjuster Ring dial

15

Front Drive Train Assembly - Spool Assembly

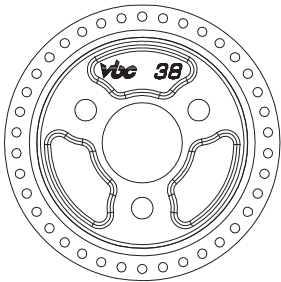

Front Spool 38T A-03-VBC-0021 x 1

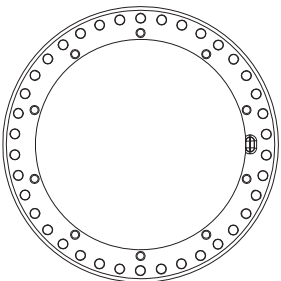

Pulley Belt Guide A-03-VBC-0022 x 1

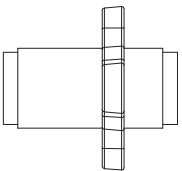

Spool Drive Shaft A-03-VBC-0049 x 1

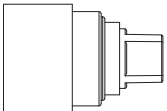

Front Spool Outdrive A-03-VBC-0055 x 2

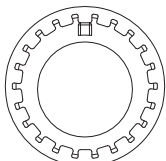

Belt Tension Adjuster Ring A-03-VBC-0047 x 2

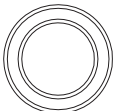

10x15 Ball Bearing C-02-BB-1510-P x 2



M3x12 Flathead C-02-SC-F0312 x 2



M3x6 Roundhead C-02-SC-R0306 x 3

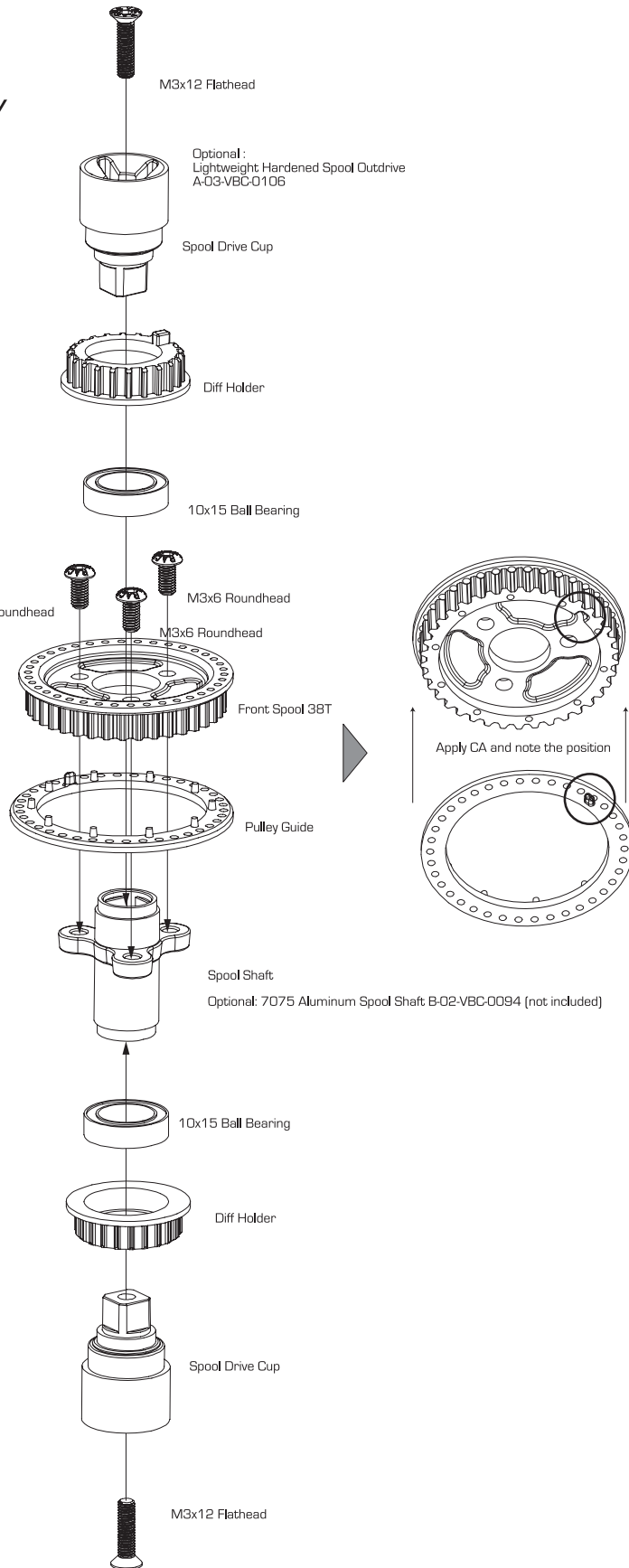

16

Assemble Front Upper Bulkhead

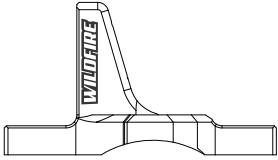

WildFireD07 Front Upper Bulkhead, Left B-02-P30146

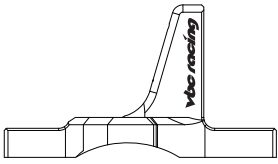

WildFireD07 Front Upper Bulkhead, Right B-02-P30147

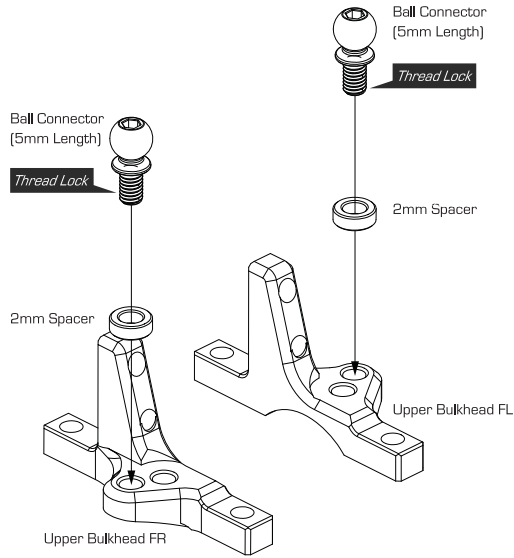

Ball Connector (5mm Length)
B-02-VBC-3021 x 2



T2 7075 Spacer B-02-VBC-0019-20 x 2



M3x8 Roundhead C-02-SC-R0307 x 4



M2x10 Roundhead C-02-SC-R2.0x10 x 2

17

Install Front Drivetrain

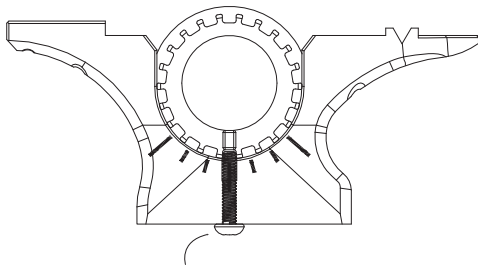

Tighten screw to lock the Belt Tension Adjuster Ring position

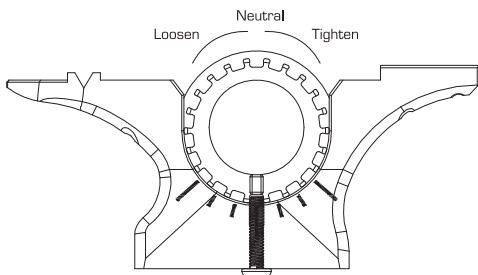

Tighten or loosen the belt tension by adjusting the Belt Tension Adjuster Ring dial

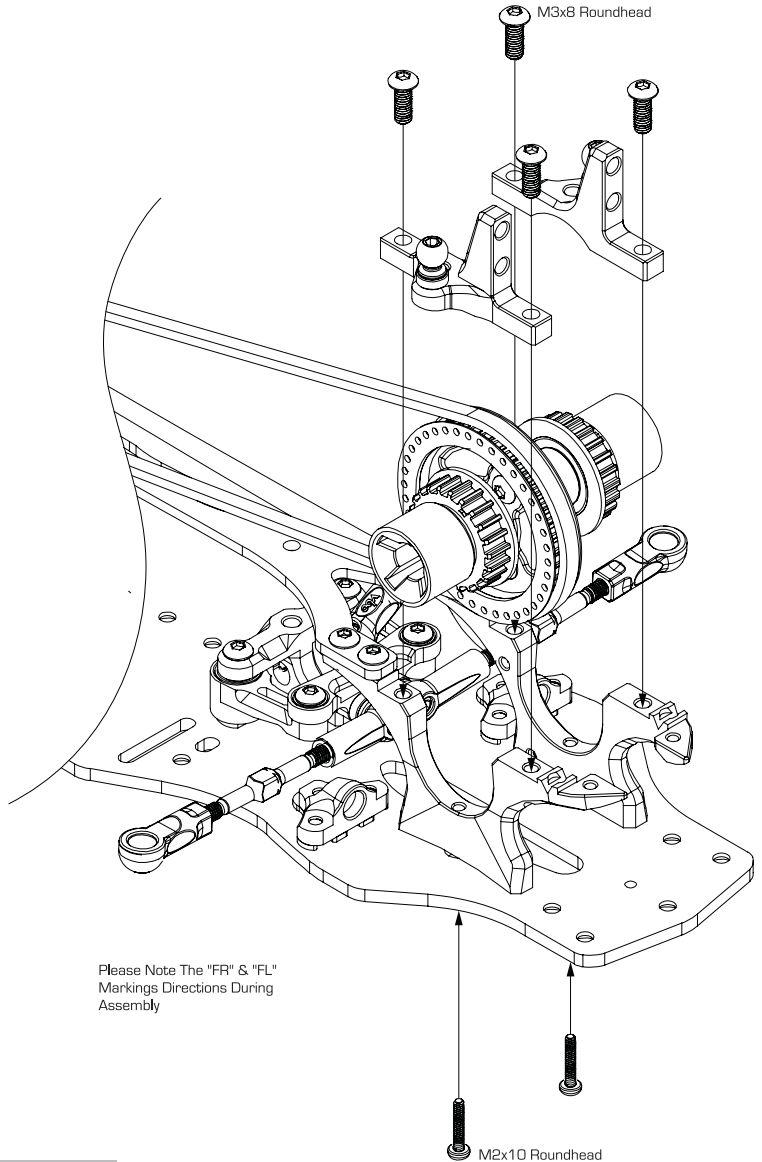

Please Note The "FR" & "FL" Markings Directions During Assembly

18

Rear Suspension Arm Assembly

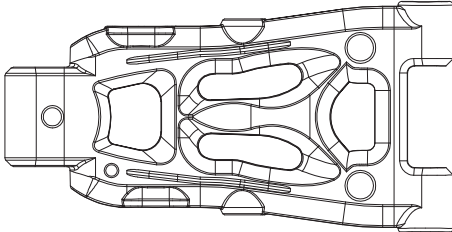

V3 Rear Suspension Arm A-03-P30268



Suspension Arm Spacer T2 Composite A-03-VBC-0052 x 2



Suspension Arm Spacer T1 Composite A-03-VBC-0051 x 4



Suspension Arm Pin B-02-VBC-0029 x 2



Arm Pin Pivot Ball B-02-VBC-0035 x 2



Ball Connector B-02-VBC-3021 x 2



Ball Connector B-02-VBC-0045 x 2



M3x10 Set Screw C-02-SC-SS-0310 x 2



E30 Suspension Mount B-02-VBC-0061-30 x 1



1mm Suspension Shim A-01-VBC-0037 x 1



M4x10 Set Screw C-02-SC-SS-0410 x 2



M3x6 Flat Head Screw C-02-SC-F0306 x 2

Rear Suspension Mount Chart :

		Narrow → Wide				
		E10	E15	E20	E25	E30
Narrow ↓ Wide	X-C15, Y-C15		0.0	0.5	1.0	1.5
	X-C10, Y-C10	0.0	0.5	1.0	1.5	2.0
	X-C05, Y-C05	0.5	1.0	1.5	2.0	2.5
	C0	1.0	1.5	2.0	2.5	3.0
	Y-C05, X-C05	1.5	2.0	2.5	3.0	3.5
	Y-C10, X-C10	2.0	2.5	3.0	3.5	4.0
Y-C15, X-C15		2.5	3.0	3.5	4.0	

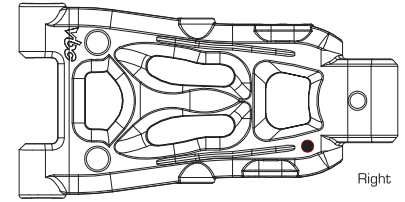
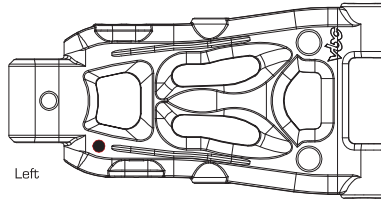

Rear Suspension Arm top view

Left

Right

Make sure the black markings are in the same direction on the left and right suspension arms

Insert M4x10 Set Screw from the top of the suspension arm for adjusting down stop. Initial setting is 1.8mm measuring from the bottom part of the arm for both sides.

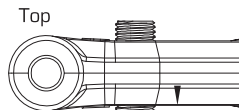
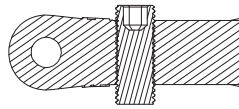

Top

Bottom

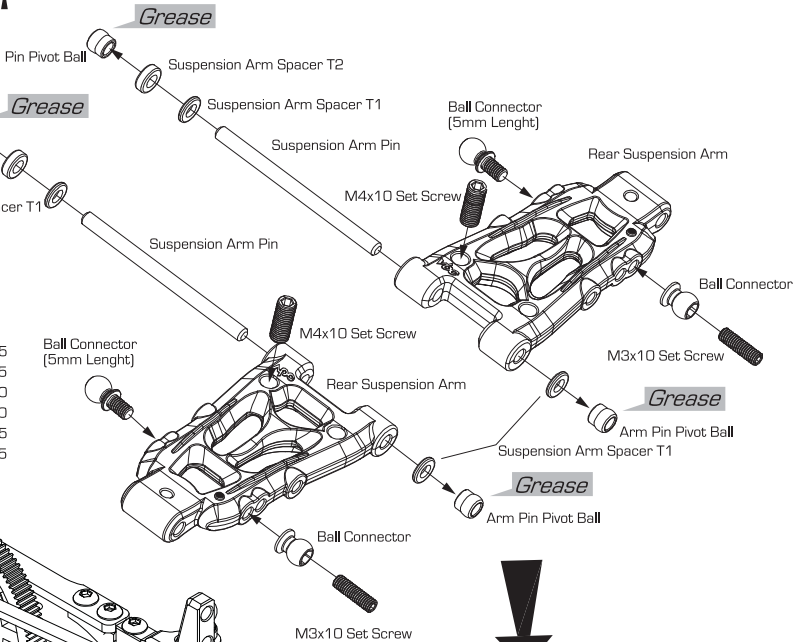

After installing the rear arms, make sure the arms can move freely

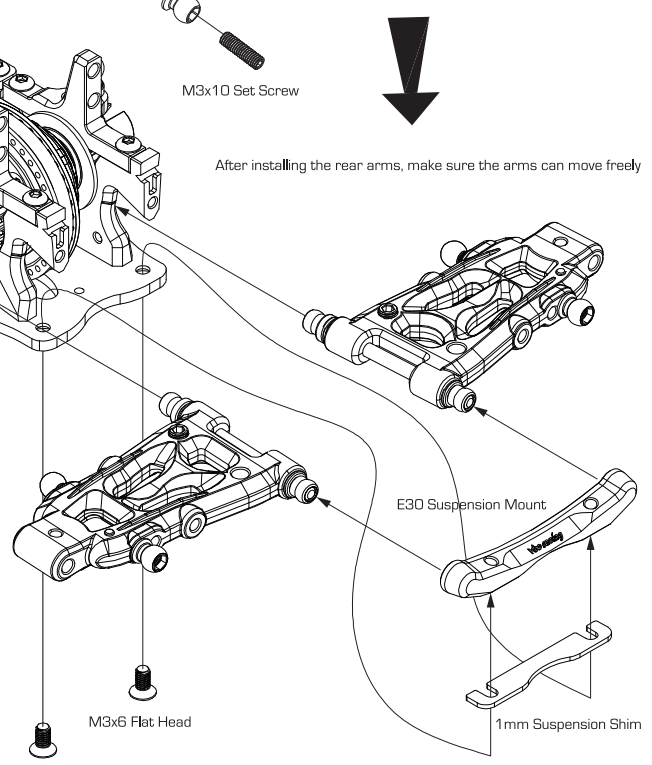

19

Rear Suspension Arm Assembly Part 2

Align the Shaft End Shoe to the Inner Axle Pin hole first and slide the 12mm Shaft Pin to the pin hole before securing the pin with M3x2 Set Screw

Note The Lock Slot Direction

M2x12 Shaft Pin

Optional: Shaft End Shoe (Self Lubricating) A-03-VBC-0077

Shaft End Shoe

Thread Lock

M3x2 Set Screw

Grease

Axle Joint

Grease

Inner Axle

Optional: 7075-T6 Rear Inner Axle (49mm), Short D-05-VBC-0086

Hardened Steel Rear Inner Axle (49mm), Short D-05-VBC-0087

49mm Two-Piece Joiny Drive Axle Set, Short D-05-VBC-0092

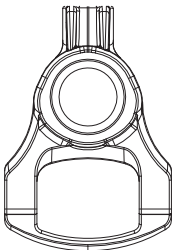

Rear Upright One Hole (Composite) A03P30178 x 1



Shaft End Shoe A-03-VBC-0038 x 2

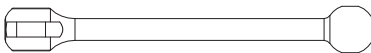

Inner Axle B-02-VBC-0024 x 2

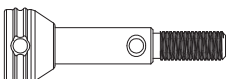

Wheel Axle B-02-VBC-0025 x 2



Axle Joint B-02-VBC-0026 x 2



Axle Lock Spring B-02-VBC-0027 x 2



5x10mm Ball Bearings C-02-BB-1005-P x 4



M2x12 Shaft Pin B-02-VBC-3035 x 2



M2x10 Shaft Pin B-02-VBC-0020 x 4



M3x10 Set Screw C-02-SC-SS-0310 x 2



M3x2 Set Screw C-02-SC-SS-0302 x 2



M1.6x4 Screw C-02-SC-R1.6x4 x 2



0 Offset Hex Wheel Hub B-02-VBC-0051 x 2



Ball Connector (7.5mm Length) B-02-VBC-3022 x 2



T2 7075 Spacer B-02-VBC-0019:20 x 2

Ball Connector (7.5mm Length)

T2 7075 Spacer

5x10mm Ball Bearings

5x10mm Ball Bearings

Axle Lock Spring

Wheel Axle

M2x10 Shaft Pin

Rear Suspension Upright

Optional RearSuspensionUpright(Composite) A-03-VBC-0037	Rear Upright One Hole (Composite) A03P30178
Soft	Hard

Joint cross section

Wheel Axle

Axle Lock Spring

Make sure the Axle Lock Spring is place correctly onto the Wheel Axle

Align the Shaft End Shoe to the Inner Axle Pin hole first and slide the 12mm Shaft Pin to the pin hole before securing the pin with M3x2 Set Screw

Grease

Axle Lock Spring

5x10mm Ball Bearings

Rear Suspension Upright

Grease

Grease

M2x10 Shaft Pin

M2x10 Shaft Pin

Inner Axle

M3x2 Set Screw

After assembling the drive shaft, make sure the joints are free swinging.

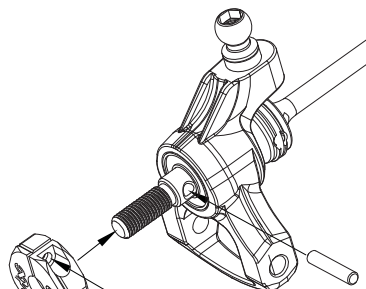

0 Offset Hex Wheel Hub

M1.6x4 Screw

M2x10 Shaft Pin

Do not over tighten the M1.6x4 screw to prevent stripping

20

Rear Suspension Arm Assembly Part 3



Turnbuckle Cup A-03-VBC-0039 x 2



Turnbuckle Cup S A-03-VBC-0056 x 2



M3x32mm Turnbuckle B-02-VBC-0036 x 2



M3x23 Upright Pin B-02-VBC-0032 x 2



3x5x0.5mm Shim B-02-VBC-0019-05 x 2



M3x4 Set Screw C-02-SC-SS-0304 x 2

MAKE TWO

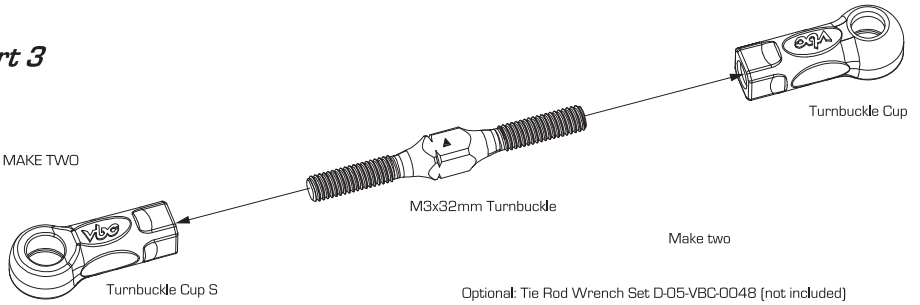

Optional: Tie Rod Wrench Set D-05-VBC-0048 (not included)



Make sure the turnbuckle caps move freely after snapped to the ball connector

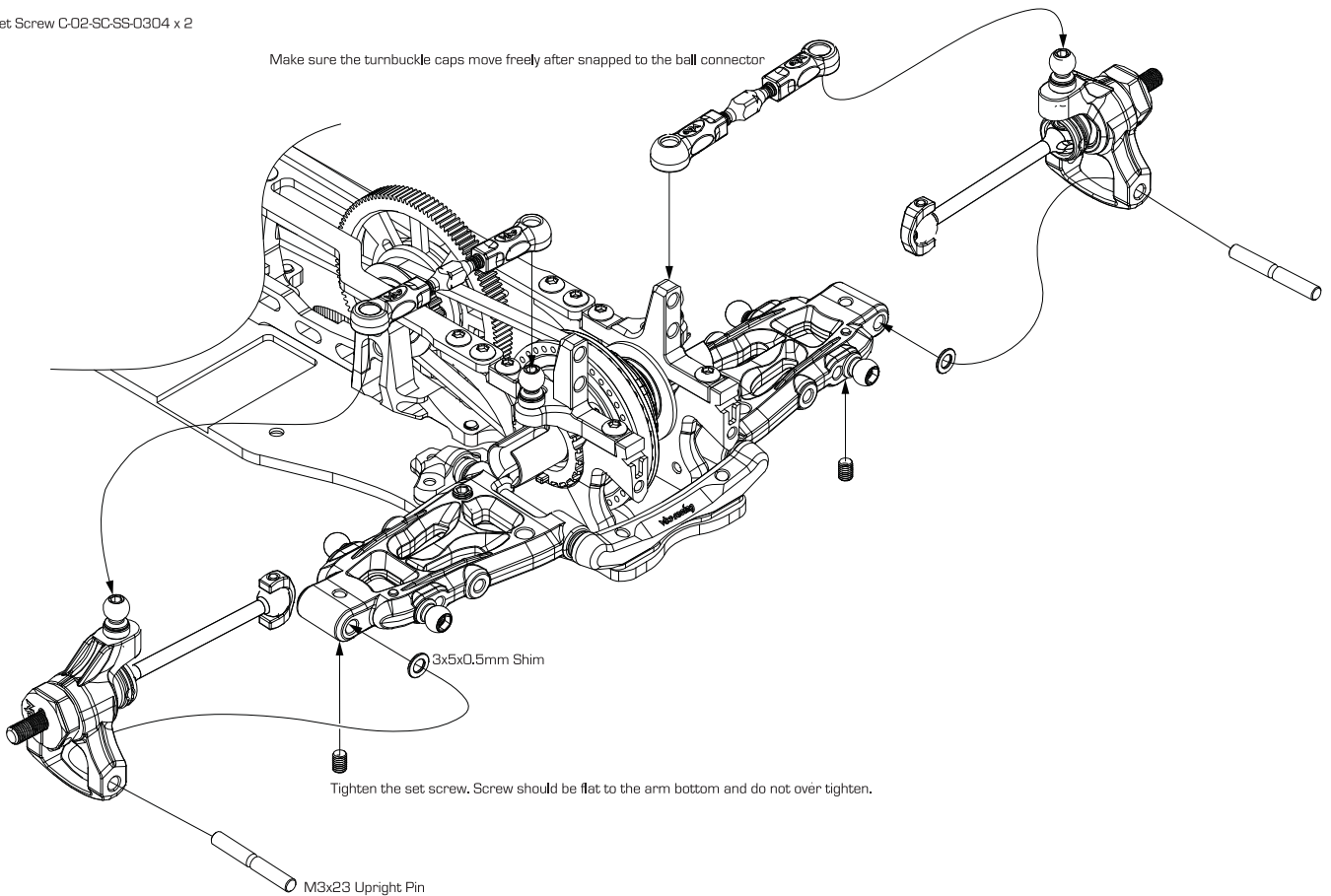

Tighten the set screw. Screw should be flat to the arm bottom and do not over tighten.

M3x23 Upright Pin

21

Front Suspension Assembly Part 1

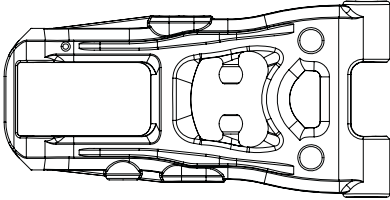

V3 Front Suspension Arm A-03-P30267

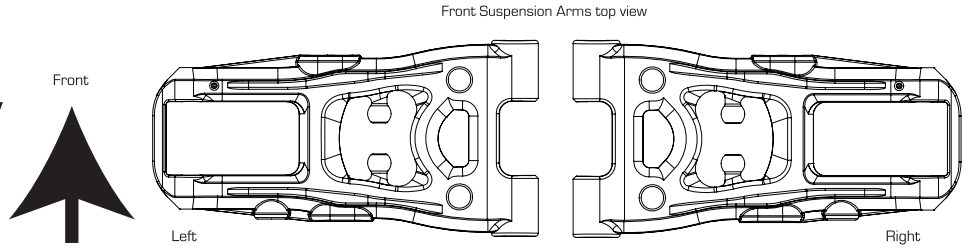

Make sure the black markings are in the same direction on the left and right suspension arms

Optional	Optional	
FrontSuspensionArm(Soft)	V2 Front Suspension Arm	V3 Front Suspension Arm
A-03-VBC-0061	A-03-VBC-3027	A03P30267
Soft		Hard

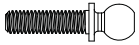

4.7x17mm Ballstud A-02-VBC-5092 x 2



Turnbuckle Cup Open Type S A-03-VBC-0040 x 2



Suspension Arm Spacer T2 A-03-VBC-0052 x 2



Suspension Arm Spacer T1 A-03-VBC-0051 x 4



Suspension Arm Pin B-02-VBC-0029 x 2



Ball Connector B-02-VBC-0045 x 4



Arm Pin Pivot Ball B-02-VBC-0035 x 4



M4x10 Set Screw C-02-SC-SS-0410 x 2



M3x10 Set Screw C-02-SC-SS-0310 x 2

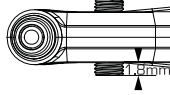

Insert M4x10 Set Screw from the top of the suspension arm for adjusting down stop. Initial setting is 1.8mm measuring from the bottom part of the arm for both sides.

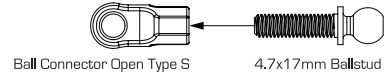

Ball Connector Open Type S 4.7x17mm Ballstud

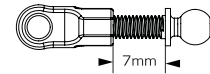

7mm Make 2 sets

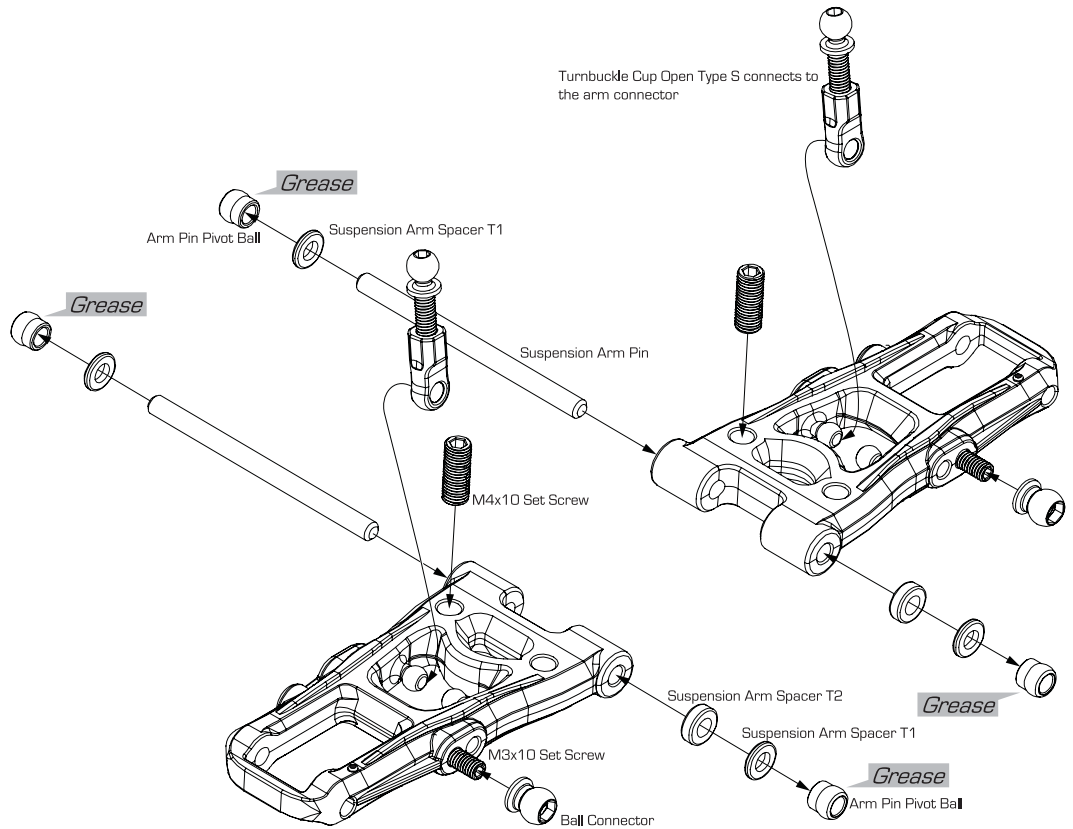

22

Front Suspension Assembly Part 2

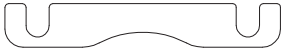

1mm Suspension Shim A-01-VBC-0037 x 1



F00 Suspension Mount B-02-VBC-0060-00 x 1



M3x6 Flat Head Screw C-02-SC-F0306 x 2

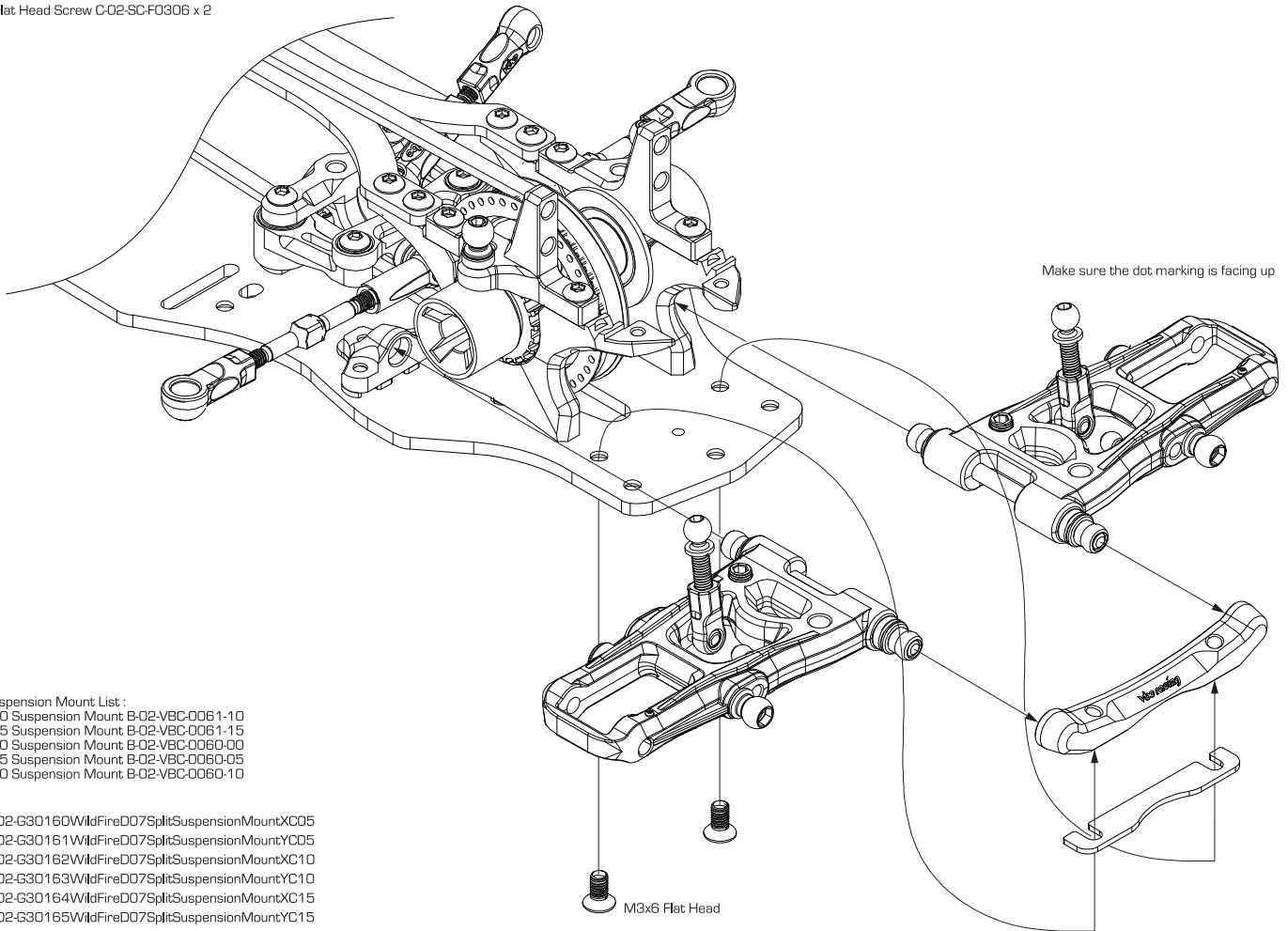

Suspension Mount List :

- E10 Suspension Mount B-02-VBC-0061-10
- E15 Suspension Mount B-02-VBC-0061-15
- F00 Suspension Mount B-02-VBC-0060-00
- F05 Suspension Mount B-02-VBC-0060-05
- F10 Suspension Mount B-02-VBC-0060-10

- B-02-G30160WildFireD07SplitSuspensionMountXC05
- B-02-G30161WildFireD07SplitSuspensionMountYC05
- B-02-G30162WildFireD07SplitSuspensionMountXC10
- B-02-G30163WildFireD07SplitSuspensionMountYC10
- B-02-G30164WildFireD07SplitSuspensionMountXC15
- B-02-G30165WildFireD07SplitSuspensionMountYC15

Front Suspension Mount Chart :

		Narrow ← → Wide				
		E10	E15	F00	F05	F10
Narrow ↓ Wide	X-C15, Y-C15	-0.5	-1.0	-1.5	-2.0	-2.5
	X-C10, Y-C10	0.0	-0.5	-1.0	-1.5	-2.0
	X-C05, Y-C05		0.0	-0.5	-1.0	-1.5
	C0			0.0	-0.5	-1.0
	Y-C05, X-C05				0.0	-0.5
	Y-C10, X-C10					0.0
Y-C15, X-C15						

Optional:
WildFire Front/ Rear Suspension Shim
[1mm,0.5mm] D-05-VBC-0032

23

Front Suspension Assembly Part 3

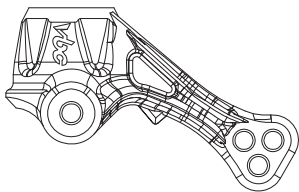

Steering Block V3 A-03-P30269 x 2

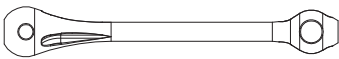

Inner Axle for Two-Piece Joint Drive Axle A-03-VBC-0069 x 2



Wheel Axle for Two-Piece Joint Drive Axle A-03-VBC-0070 x 2



Axle Inner Joint for Two-Piece Drive A-03-VBC-0087 x 4



Axle Lock Spring A-03-VBC-0072 x 4



Axle Joint for Two-Piece Joint Drive Axle A-03-VBC-0071 x 2



M1.7x8 Shaft Pin A-03-VBC-0073 x 4



5x10x3mm Ball Bearing C-02-BB-1053-B x 2



5x10x4mm Ball Bearing C-02-BB-1005-P x 2



M2x10 Shaft Pin B-02-VBC-3035 x 2



M3x2 Set Screw C-02-SC-SS-0302 x 2



M1.6x4 Screw C-02-SC-R1.6x4 x 2



0 Offset Hex Wheel Hub B-02-VBC-0051 x 2



Ball Connector (5mm Length) B-02-VBC-0021 x 2

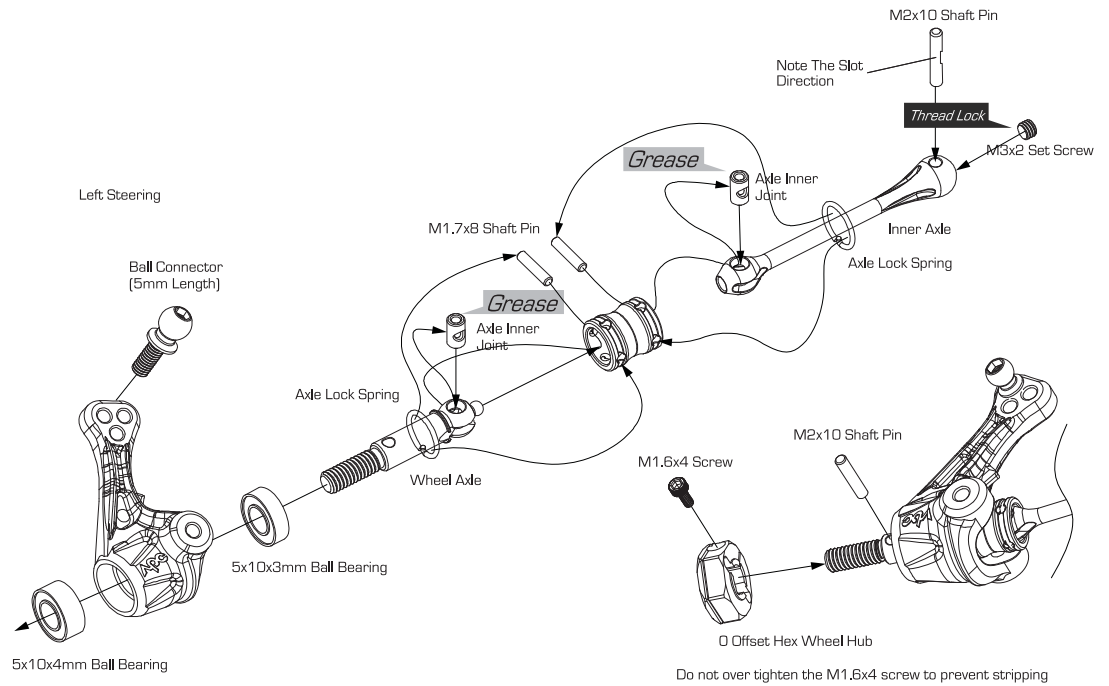

Optional	
SteeringBlockVersion2(Composite)	Steering Block V3
A-03-VBC-0079	A-03-P30269 x 2
Soft Hard	

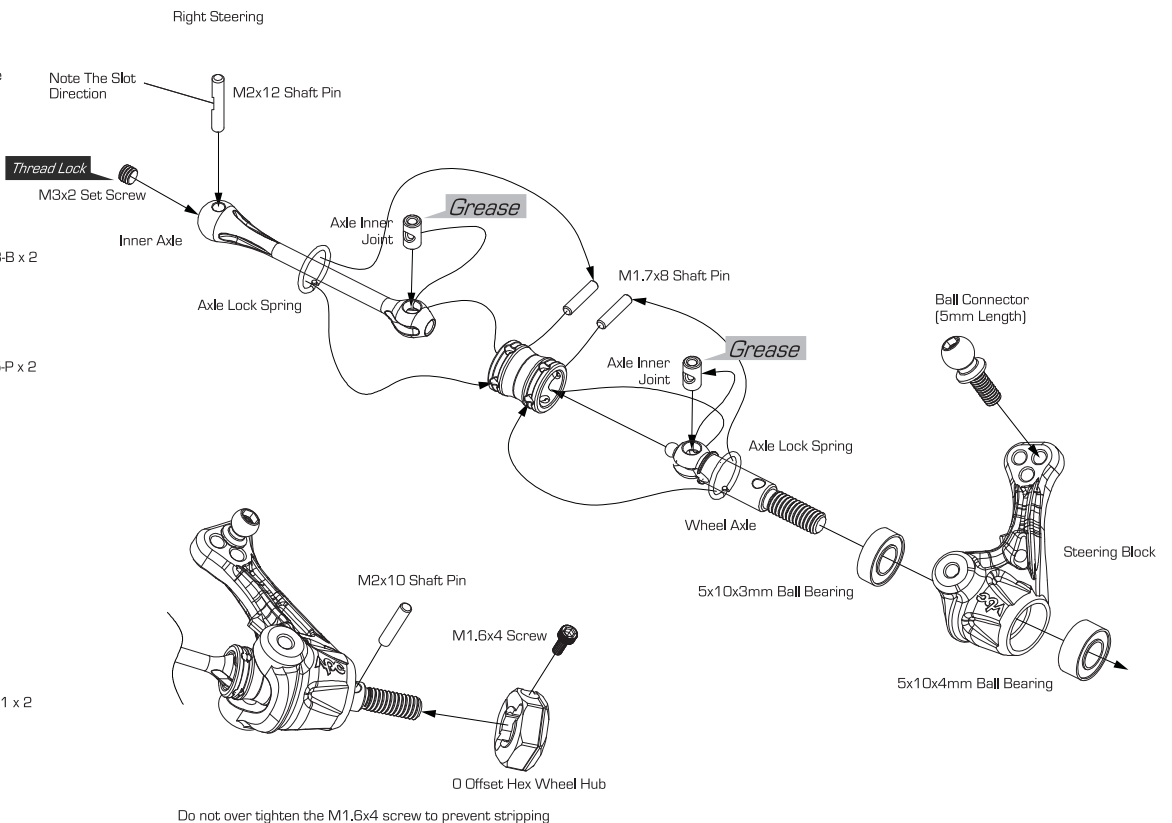

24

Front Suspension Assembly Part 4

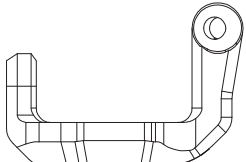

Right C-Hub V3 A-03-P30270 x 1

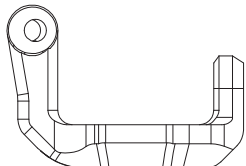

Left C-Hub V3 A-03-P30271 x 1



Turnbuckle Cup A-03-VBC-0039 x 2



Turnbuckle Cup S A-03-VBC-0056 x 2



Ball Connector B-02-VBC-0045 x 2



M3x32mm Turnbuckle B-02-VBC-0036 x 2



3x23 Upright Pin B-02-VBC-0032 x 2



Steering Swivel Tube B-02-VBC-0033 x 4



M3x12 Set Screw C-02-SC-SS-0312 x 2



M3x4 Set Screw C-02-SC-SS-0304 x 2



M3x9 Round Head Screw C-02-SC-R0309 x 2

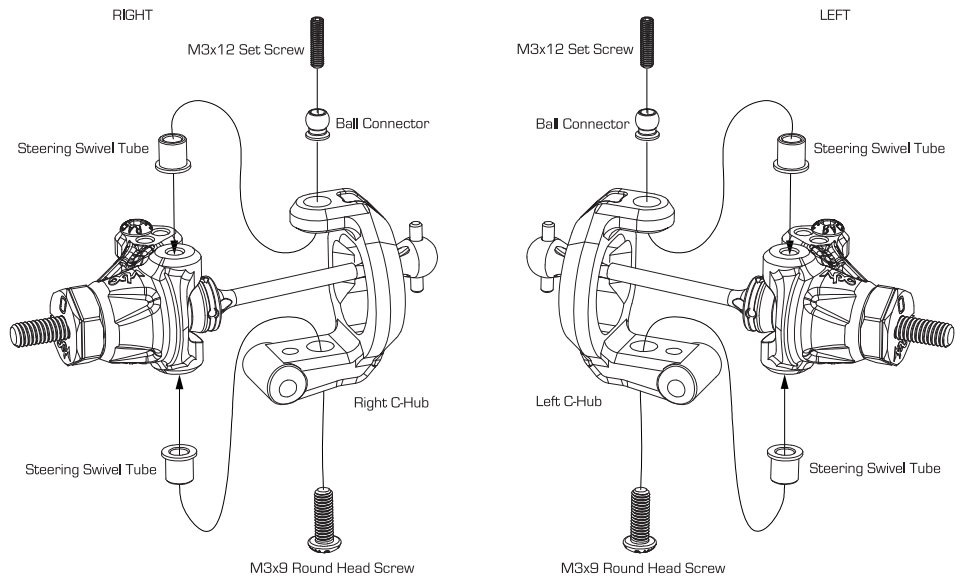

Please note the 'L'(Left) and 'R'(Right) markings on C-Hubs

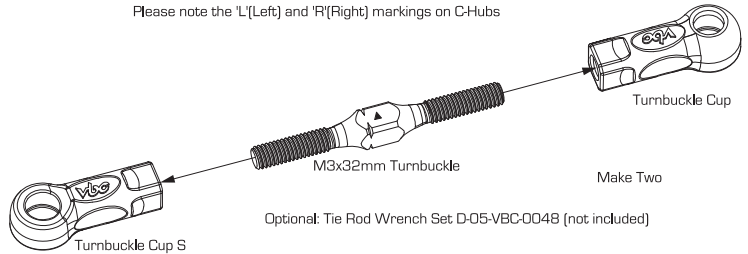

Optional: Tie Rod Wrench Set D-05-VBC-0048 (not included)

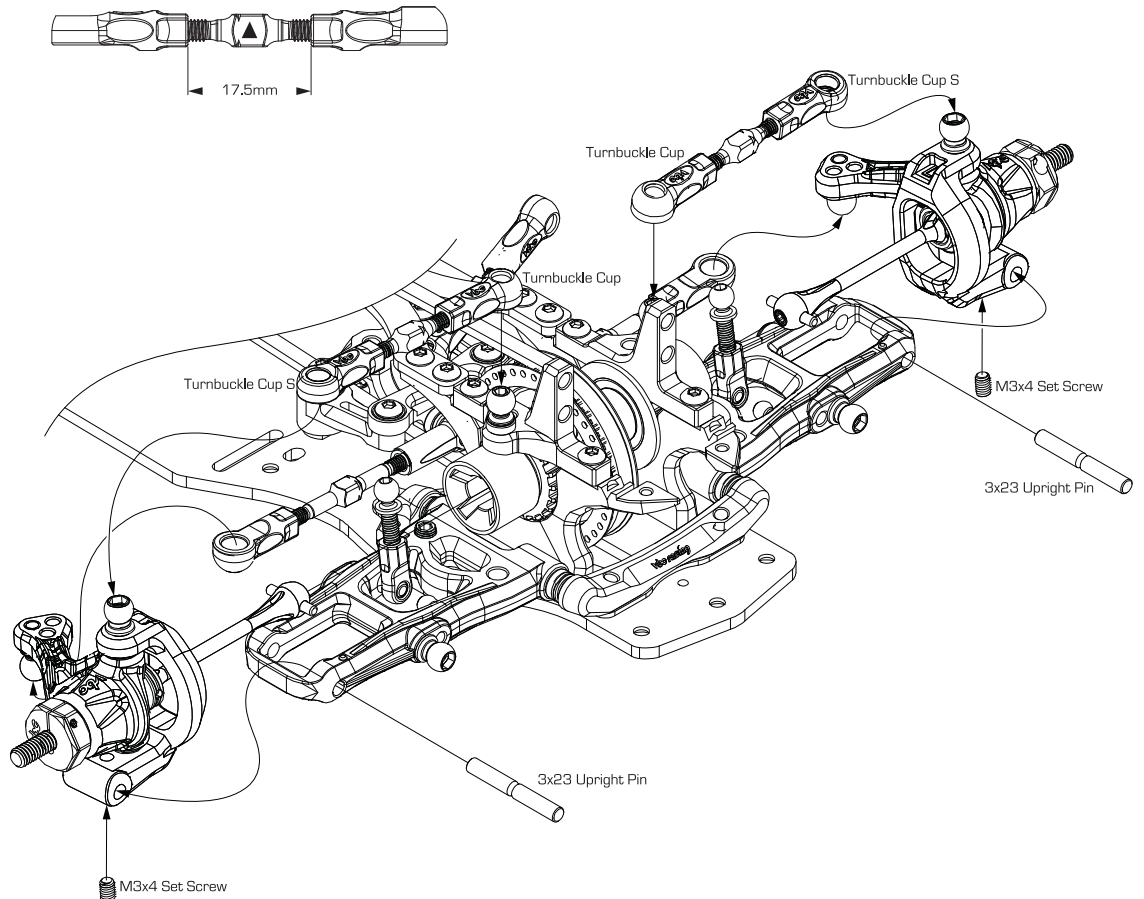

25

Front and Rear Stabilizers

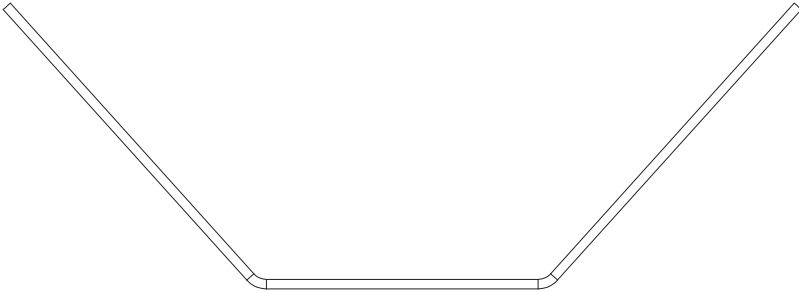

Rear Stabilizer 1.3 C-02-P30249 x 1



Front Stabilizer 1.3 C-02-P30248 x 1

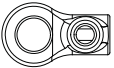

WildFireD07 Stabilizer Ball Cup A-03-P30150 x 4



M3x3mm Set Screw C-02-SC-SS-0303 x 6



Stabilizer Stopper B-02-VBC-3025 x 2

REAR STABILIZER

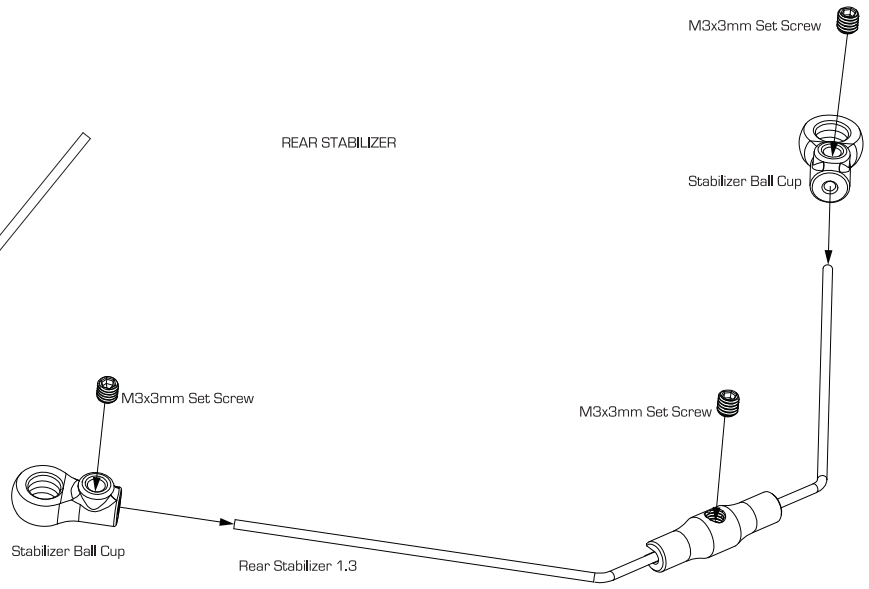

Optional:
D07 Rear Stabilizer 1.4 White Option C-02-G30253
D07 Rear Stabilizer 1.2 Green Option C-02-G30251

FRONT STABILIZER

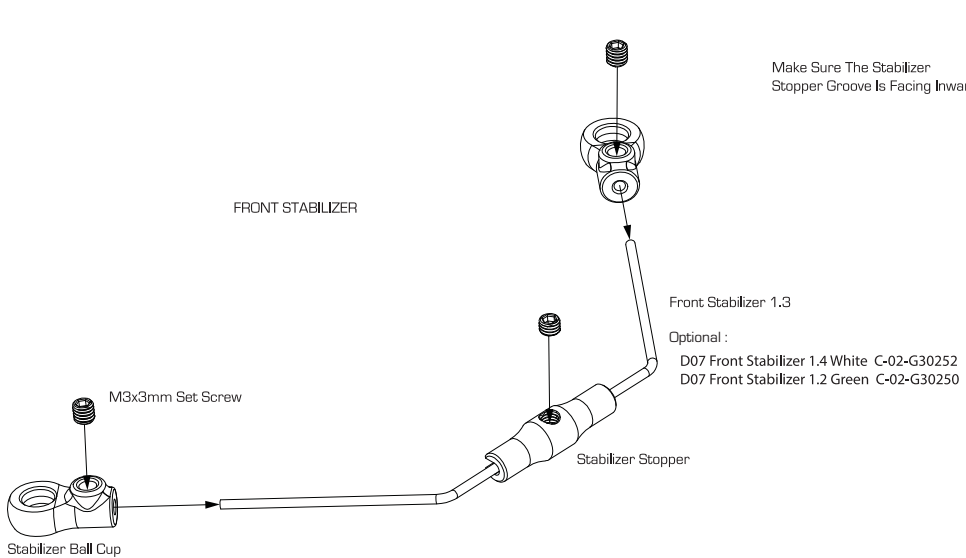

Optional:
D07 Front Stabilizer 1.4 White C-02-G30252
D07 Front Stabilizer 1.2 Green C-02-G30250

26

Install Front and Rear Stabilizers

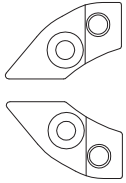

Stabilizer Mount (Front) B-02-VBC-0023 x 2

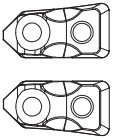

Stabilizer Mount (Rear) B-02-VBC-0024 x 2

M3x3mm Set Screw C-02-SC-SS-0303 x 4

M2.5x6mm Flat Head Screw C-02-SC-F0256 x 4

INSTALL FRONT STABILIZER

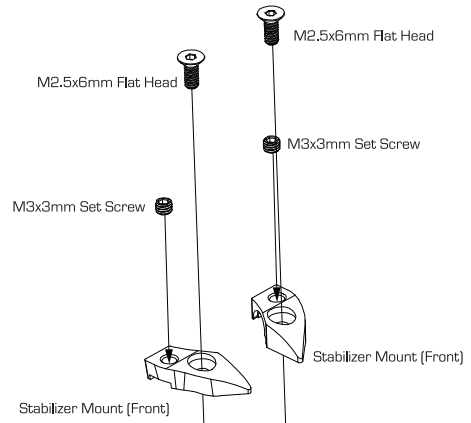

INSTALL REAR STABILIZER

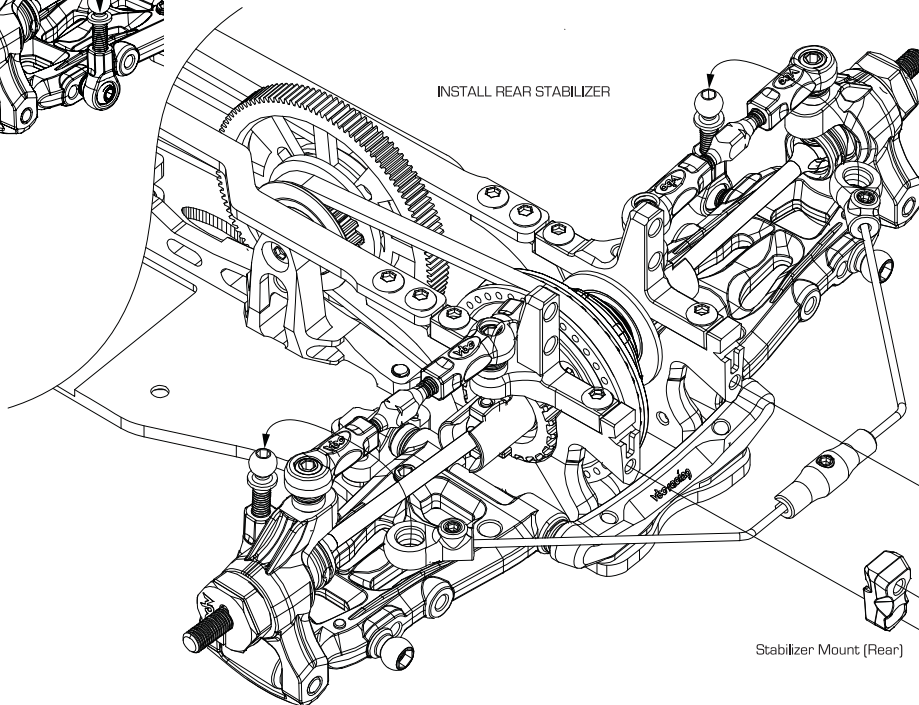
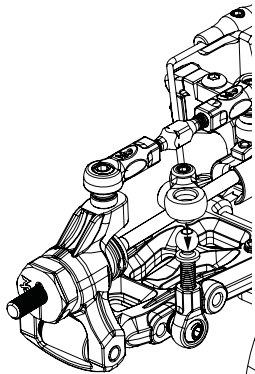

27

Assemble Oil Shocks

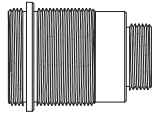

TBB Shock Body B-02-VBC-0120 x 4

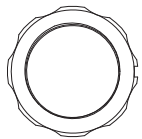

TBB Shock Height Adjuster B-02-VBC-0121 x 4



TBB Shock Bottom Cap A-03-VBC-0122 x 4

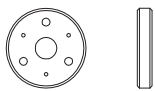

TBB Shock Piston (3 holes) A-03-VBC-0123 x 4

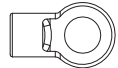

TBB Shock Bottom Connector A-03-VBC-0124 x 4



TBB Shaft Cap B-03-VBC-0125 x 4



TBB Shaft Guide A-03-VBC-0126 x 4

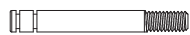

TBB Shock Shaft B-03-VBC-0127 x 4

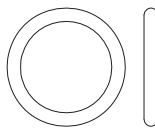

Sealer O-Ring (Shock Height Adjuster) B-03-VBC-0128 x 4



Shaft Sealer O-Ring B-03-VBC-0012 x 4



M2 E-Clip B-02-VBC-0129 x 8

MAKE 4 SHOCKS

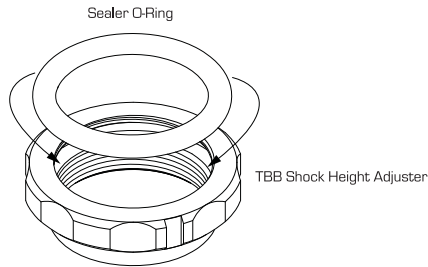

Insert Sealer O-Ring inside the Shock Height Adjuster groove

TBB Shaft Guide



Note The Direction Of Slot On Bottom

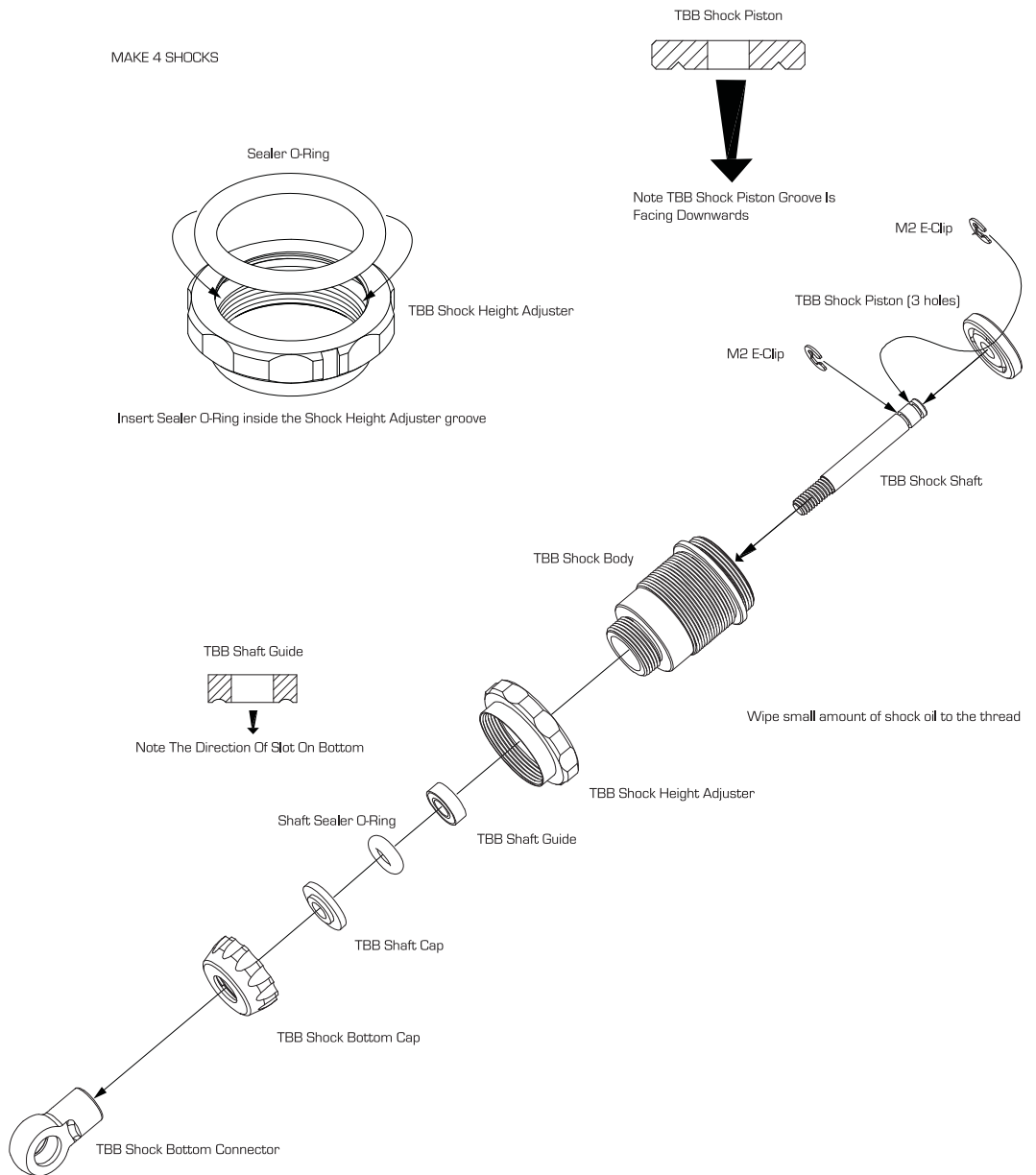

TBB Shock Piston

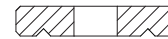

Note TBB Shock Piston Groove Is Facing Downwards

M2 E-Clip

TBB Shock Piston (3 holes)

M2 E-Clip

TBB Shock Shaft

TBB Shock Body

Wipe small amount of shock oil to the thread

TBB Shock Height Adjuster

Shaft Sealer O-Ring

TBB Shaft Guide

TBB Shaft Cap

TBB Shock Bottom Cap

TBB Shock Bottom Connector

Note the double ring face to ball connector

Make sure the shock shaft can move up and down freely

28

Assemble Oil Shocks Part 2

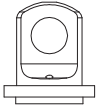

TBB Shock Top Connector A-03-VBC-0130 x 4

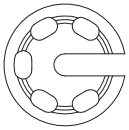

TBB Spring Bottom Support A-03-VBC-0131 x 4



TBB Oil Sealer Cap (Medium Soft)
B-03-VBC-0132 x 4



TBB Shock Body Cap B-02-VBC-0133 x 4



TBB Shock Spring
Orange-Med Hard (For Front)
B-02-VBC-0133 x 2

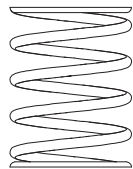

TBB Shock Spring
Red-Med Soft (For Rear)
B-02-VBC-0134 x 2

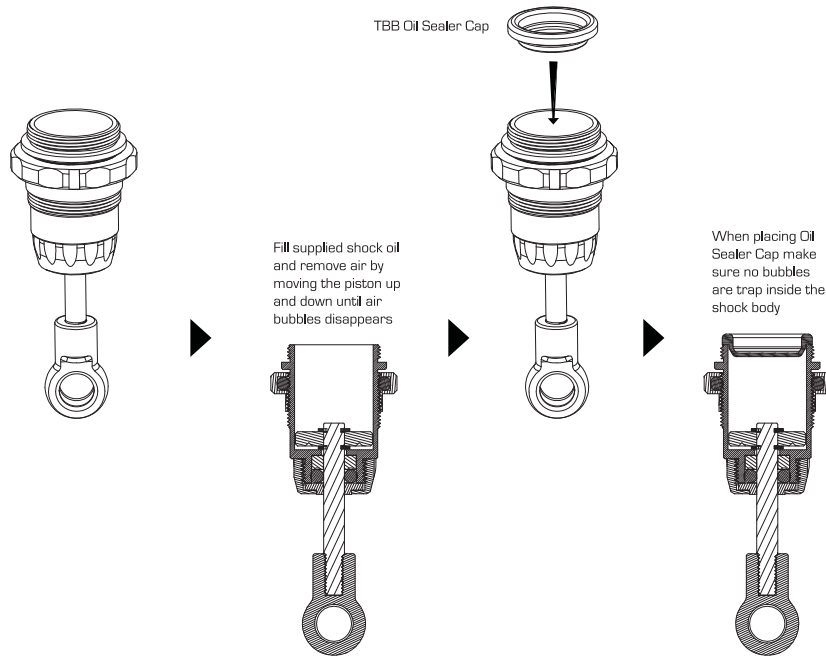
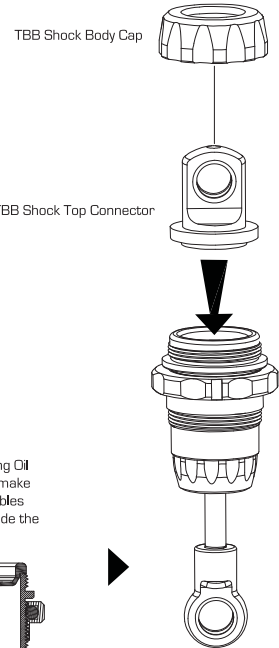

TBB Spring Bottom Support

Note the double ring face to ball connector

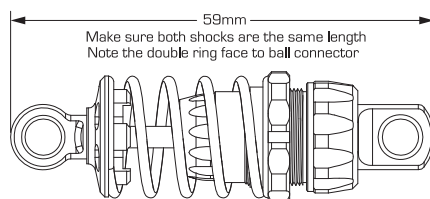
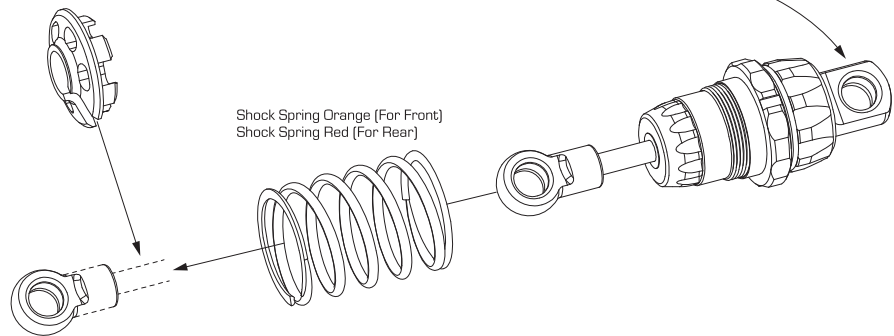

VBC Racing TBB Shock Springs:
 TBB Shock Spring (Green - Soft) B-02-VBC-0136
 TBB Shock Spring (Red - Med. Soft) B-02-VBC-0134
 TBB Shock Spring (Orange - Med. Hard) B-02-VBC-0135
 TBB Shock Spring (White - Hard) B-02-VBC-0137

Color	Green B-02-VBC-00136	Red B-02-VBC-00134	Orange B-02-VBC-00135	White B-02-VBC-0137
Rate lb/in	13.30	14.40	16.20	17.10
Rate gf/mm	238	273.2	301.8	320
Coils	6.50	6.25	6.00	5.75

29

Install Front Shocks

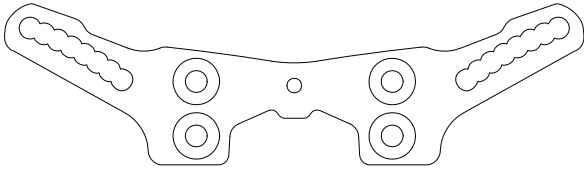

WildFireD07 Graphite Front Shock Tower
A-01-P30246 x 1

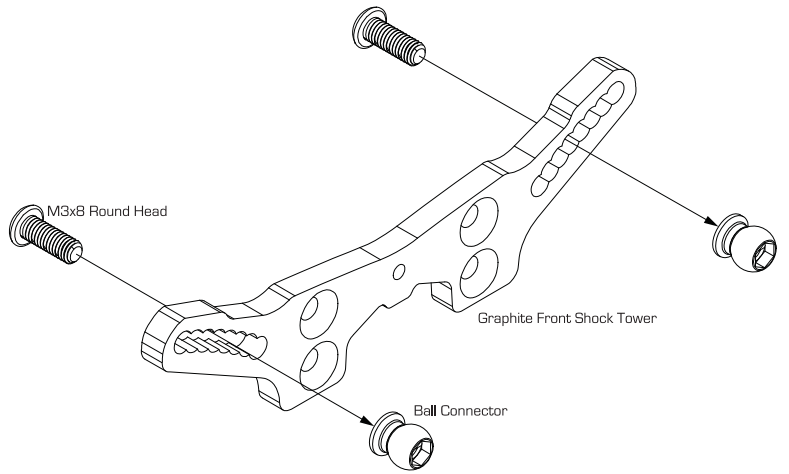

Graphite Front Shock Tower



Ball Connector B-02-VBC-0045 x 2



M3x8 Round Head Screw C-02-SC-R0308 x 2

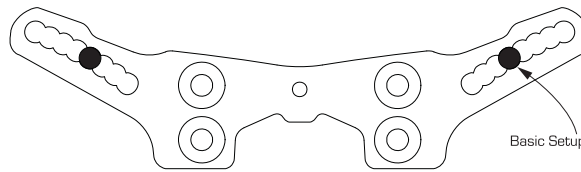

Basic Setup Shock Position



M3x8 Flat Head Screw C-02-SC-F0308 x 4

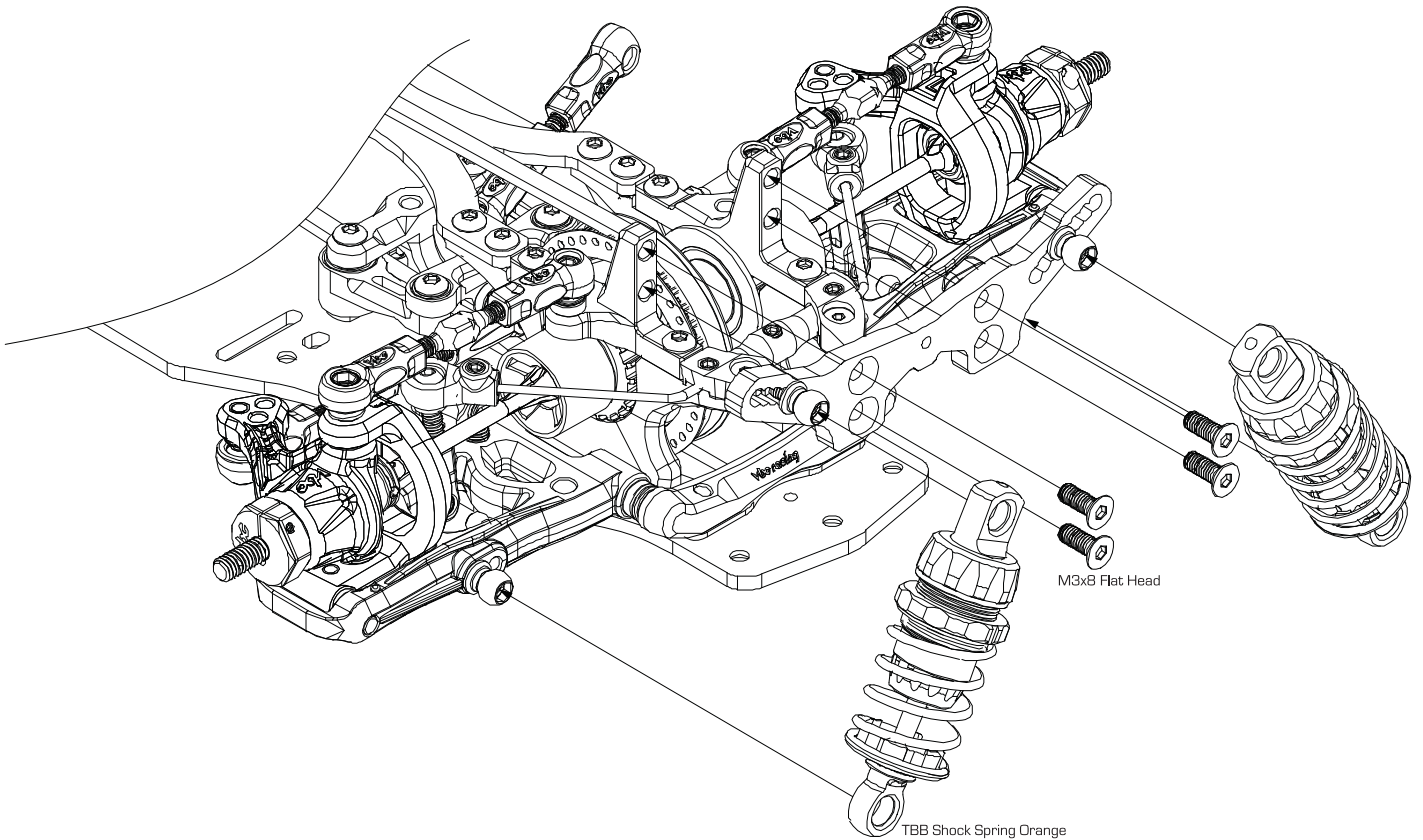

M3x8 Flat Head

TBB Shock Spring Orange

30

Install Rear Shocks

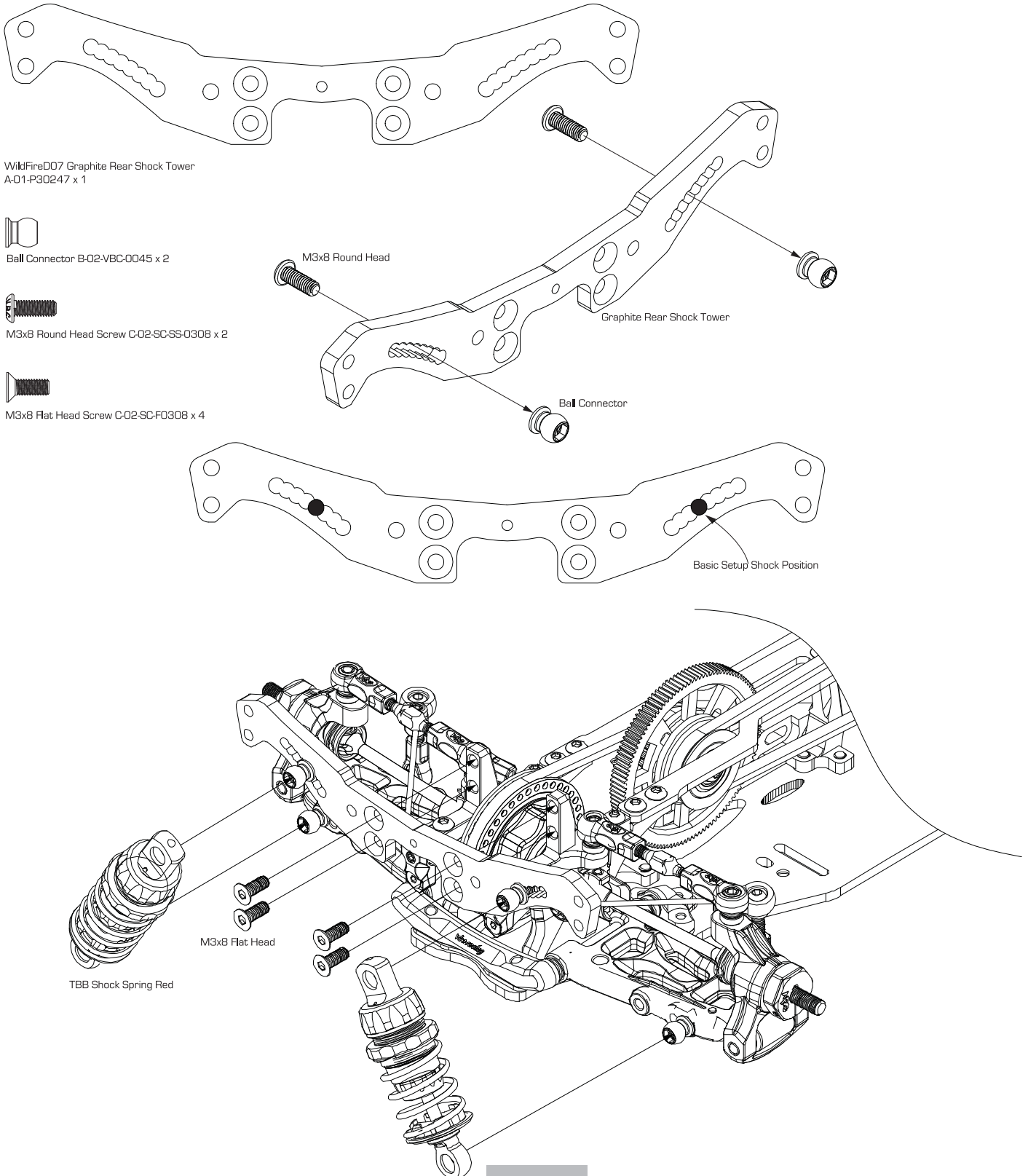

31

Install Motor

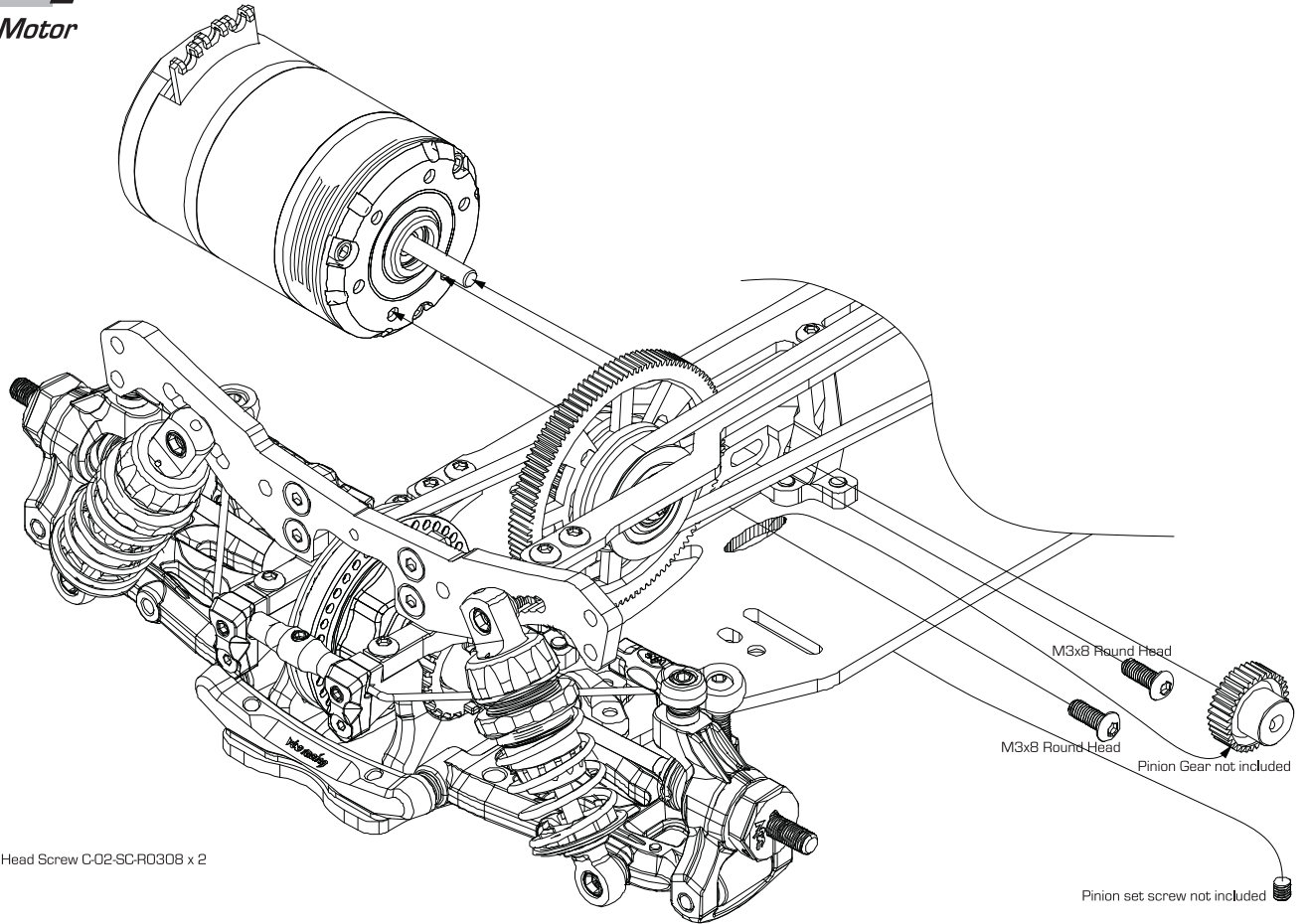

M3x8 Round Head Screw C-02-SC-R0308 x 2

All-new motor mount can incorporate a wider range of gear ratios from 21.5 up to modified classes
Please make sure there is enough clearance for the gears to run smoothly

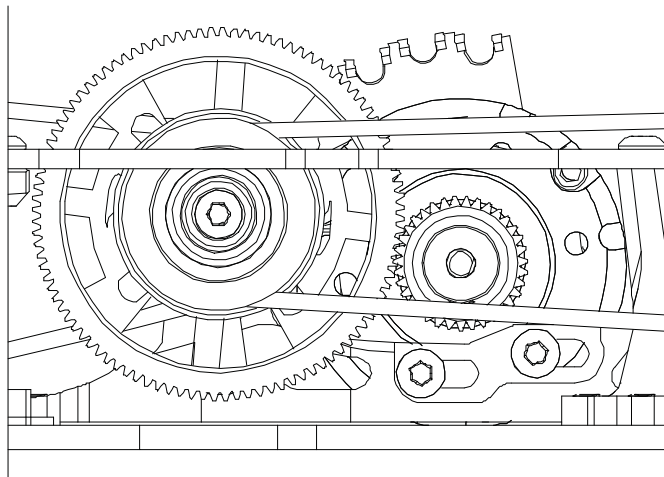

32

Install Steering Servo

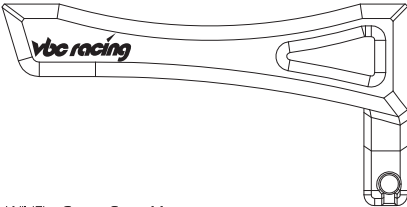

WildFire Center Servo Mount
D-05-VBC-0089 x 1



Servo Spacer 2mm A-03-VBC-0033 x 2
Optional Servo Spacer 1mm A-03-VBC-0032 x 2 included

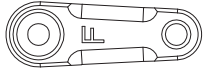

Servo Horn Type F (Futaba)
A-03-VBC-0053 x 1

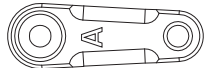

Servo Horn Type A (Airtronics/KO)
A-03-VBC-0054 x 1



M3x8mm Round Head Screw C-02-SC-R0308 x 5



M3x6 Flathead C-02-SC-F0306 x 3



Ball Connector B-02-VBC-0045 x 1



Servo Washer (not included) x 3

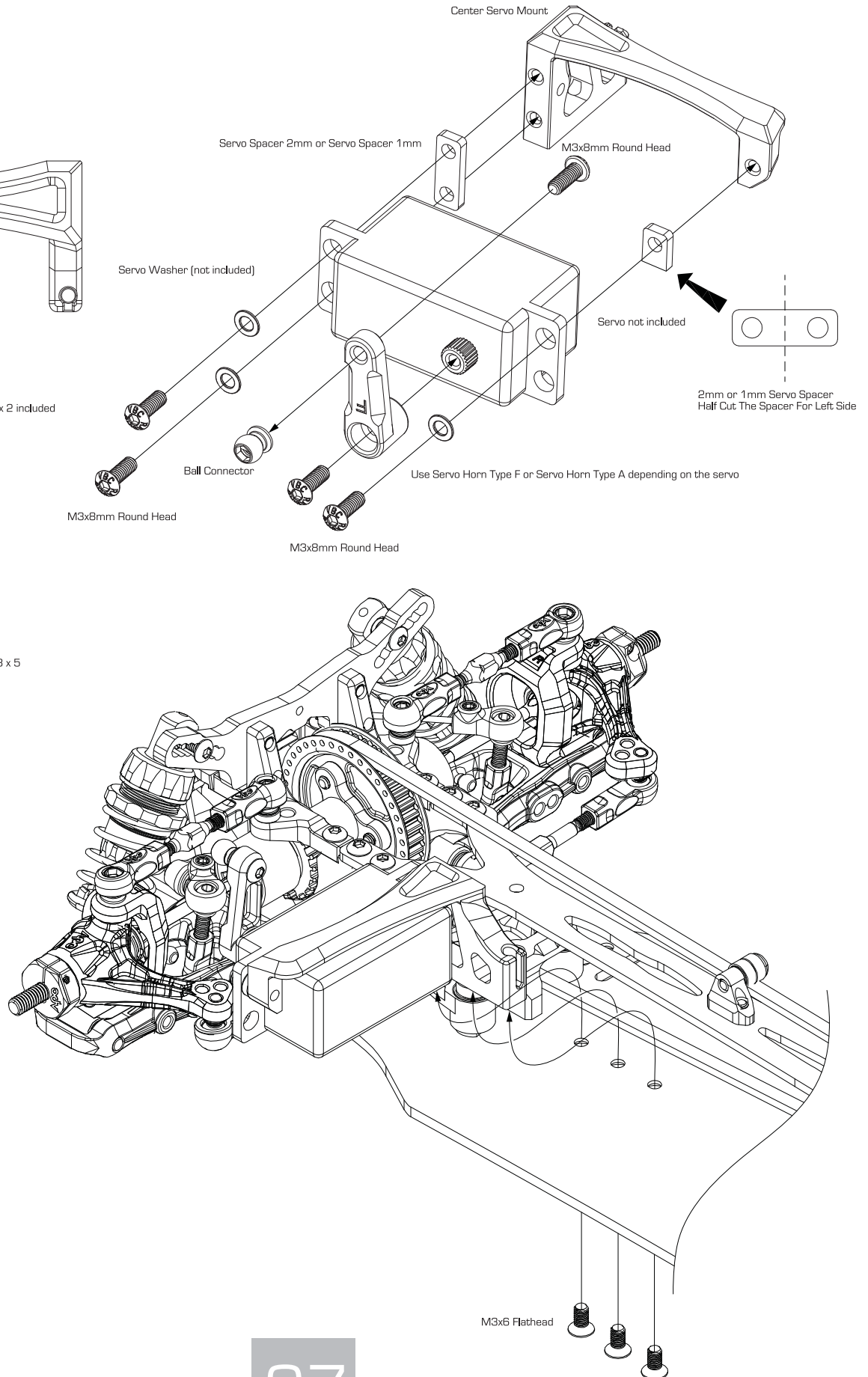

33

Install Front Bumper and Body Posts



4mm Flanged Wheel Nut B-02-VBC-0086 x 4

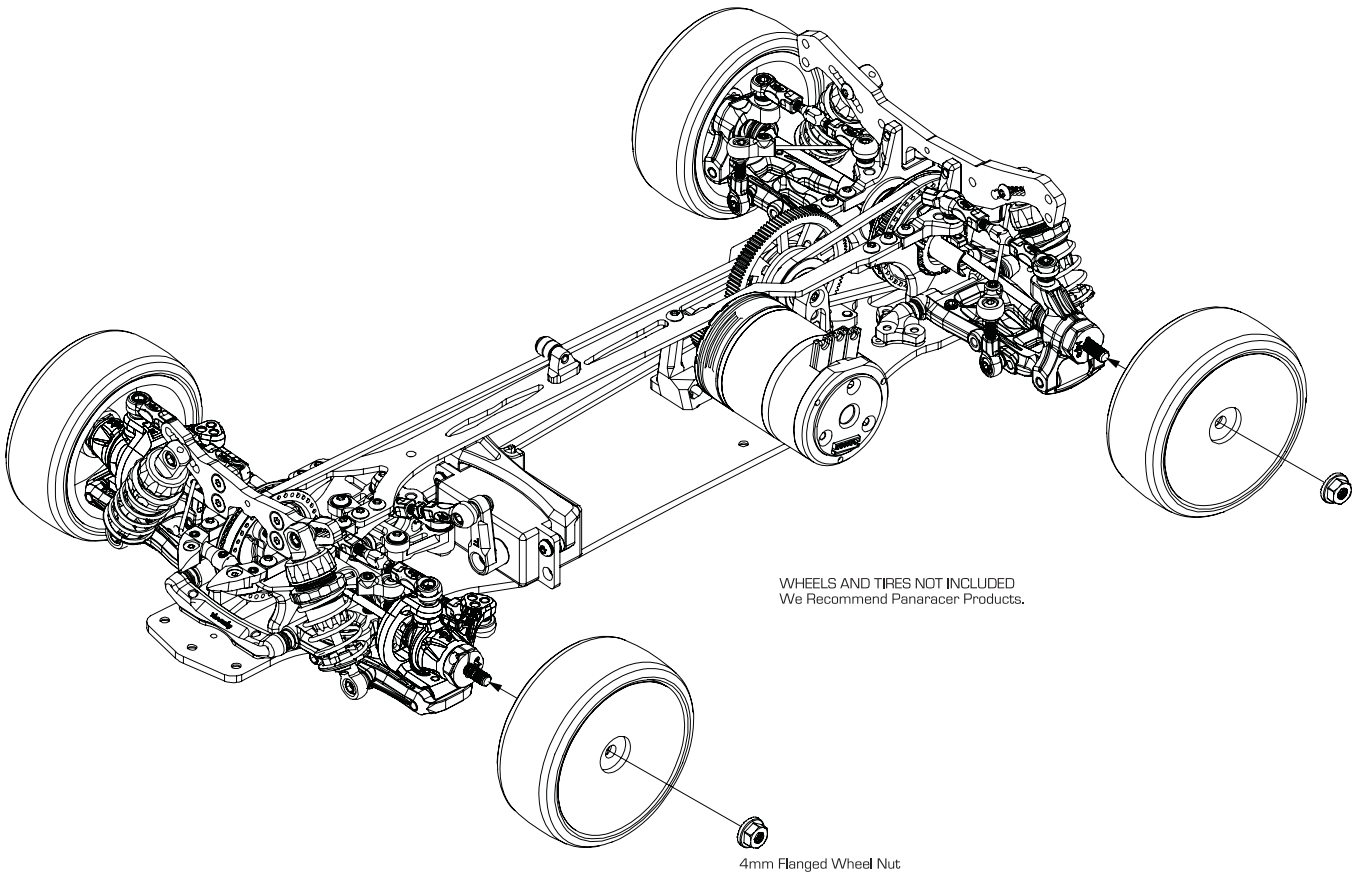

WHEELS AND TIRES NOT INCLUDED.
We Recommend Panaracer Products.

4mm Flanged Wheel Nut

34

Install Front Bumper Part 2

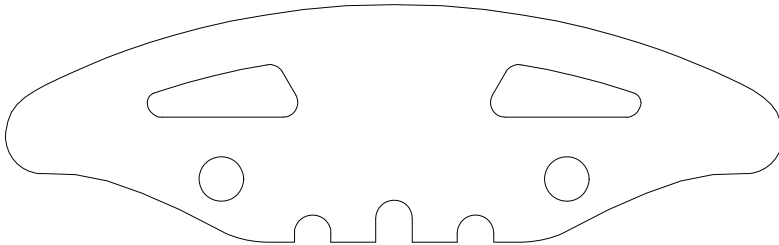

Front Foam Bumper B-03-VBC-0009 x 1

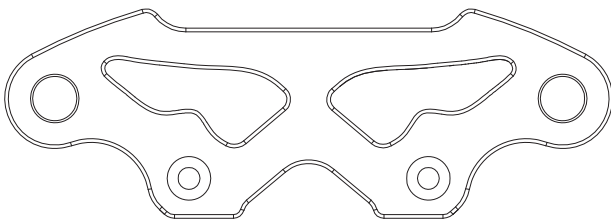

Bumper Top Plate A-03-VBC-0062 x 1

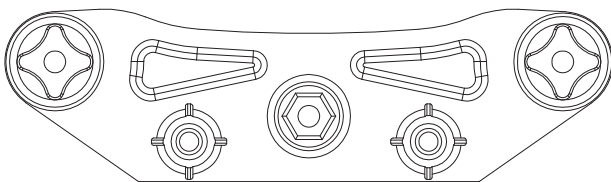

Bumper Top Plate A-03-VBC-0011 x 1



M3 Lock Nut C-02-SC-NN03 x 1



M3x10mm Flat Head Screw C-02-SC-F0310 x 4



M2x12 Shaft Pin B-02-VBC-0022 x 2



Body Clip B-02-VBC-0076 x 2



Body Height Adjuster Support A-03-VBC-0015 x 2

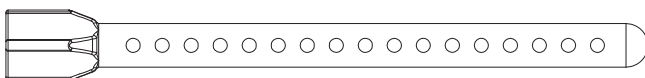

Front Body Post A-03-VBC-0013 x 2

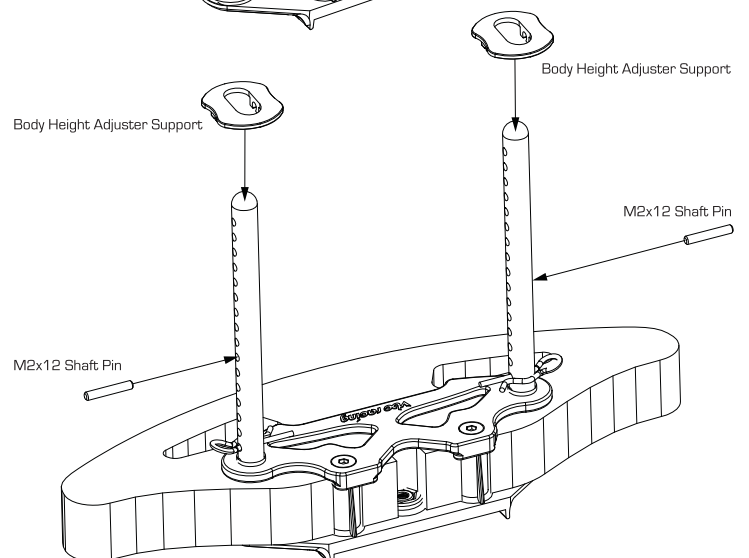
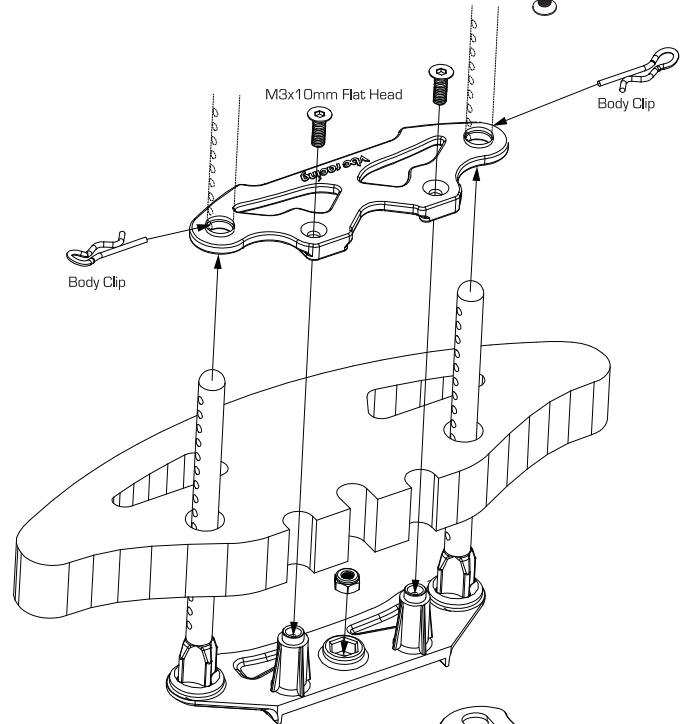
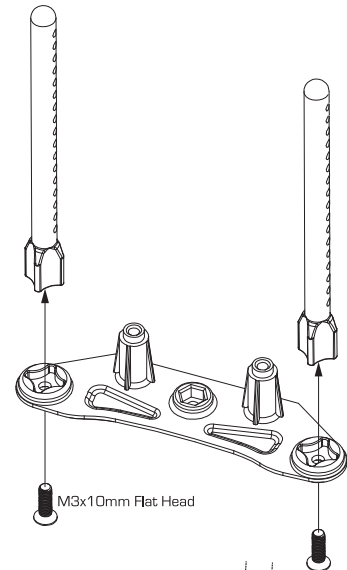

35

Install Rear Body Posts and Electronics



M3x8mm Flat Head Screw C-02-SC-F0308 x 3

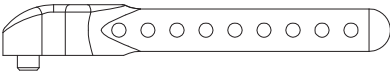

Rear Body Post A-03-VBC-0014 x 2



M3x10mm Round Head Screw C-02-SC-R0310 x 2



M2x12 Shaft Pin B-02-VBC-0020-12 x 2



Body Height Adjuster Support A-03-VBC-0015 x 2

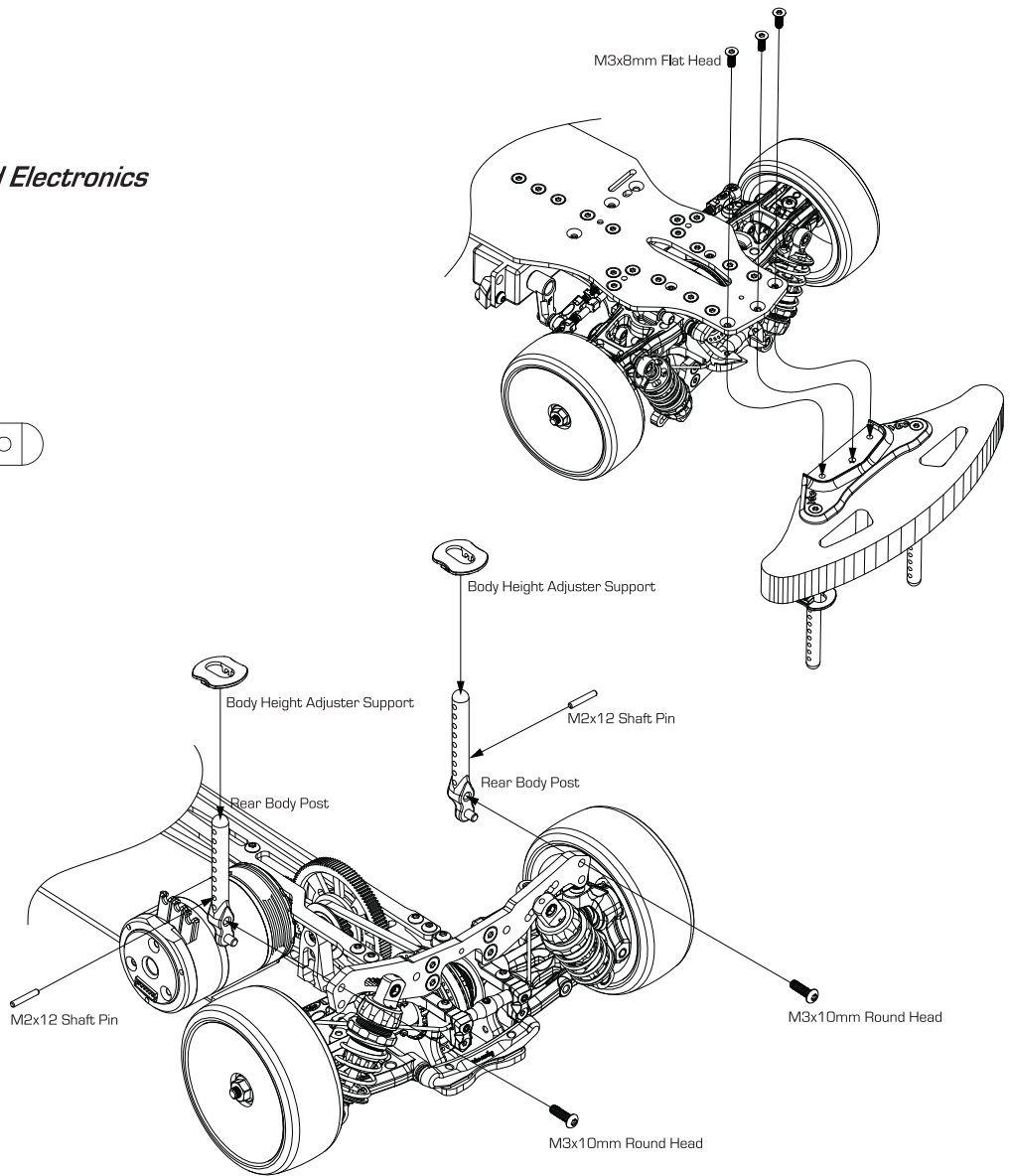

INSTALL ESC, RECEIVER AND ANTENNA TUBE
 (these items are not included in this kit)

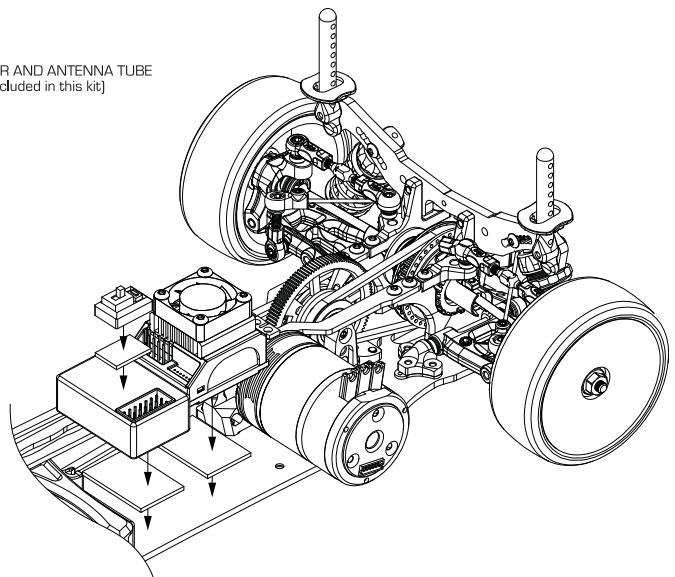

35

Continue
Install Battery Guards



Centerline Battery Stopper B-02-VBC-3034 x 1



M3x10mm Flat Head Screw
C-02-SC-F0310 x 1



M3x6 Flathead C-02-SC-F0306 x 2

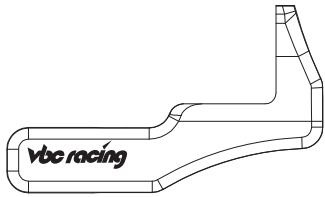
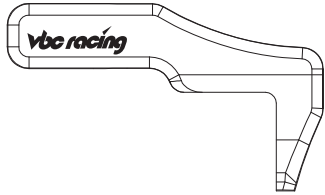

Plastic Battery Mount A-03-VBC-3025 x 1

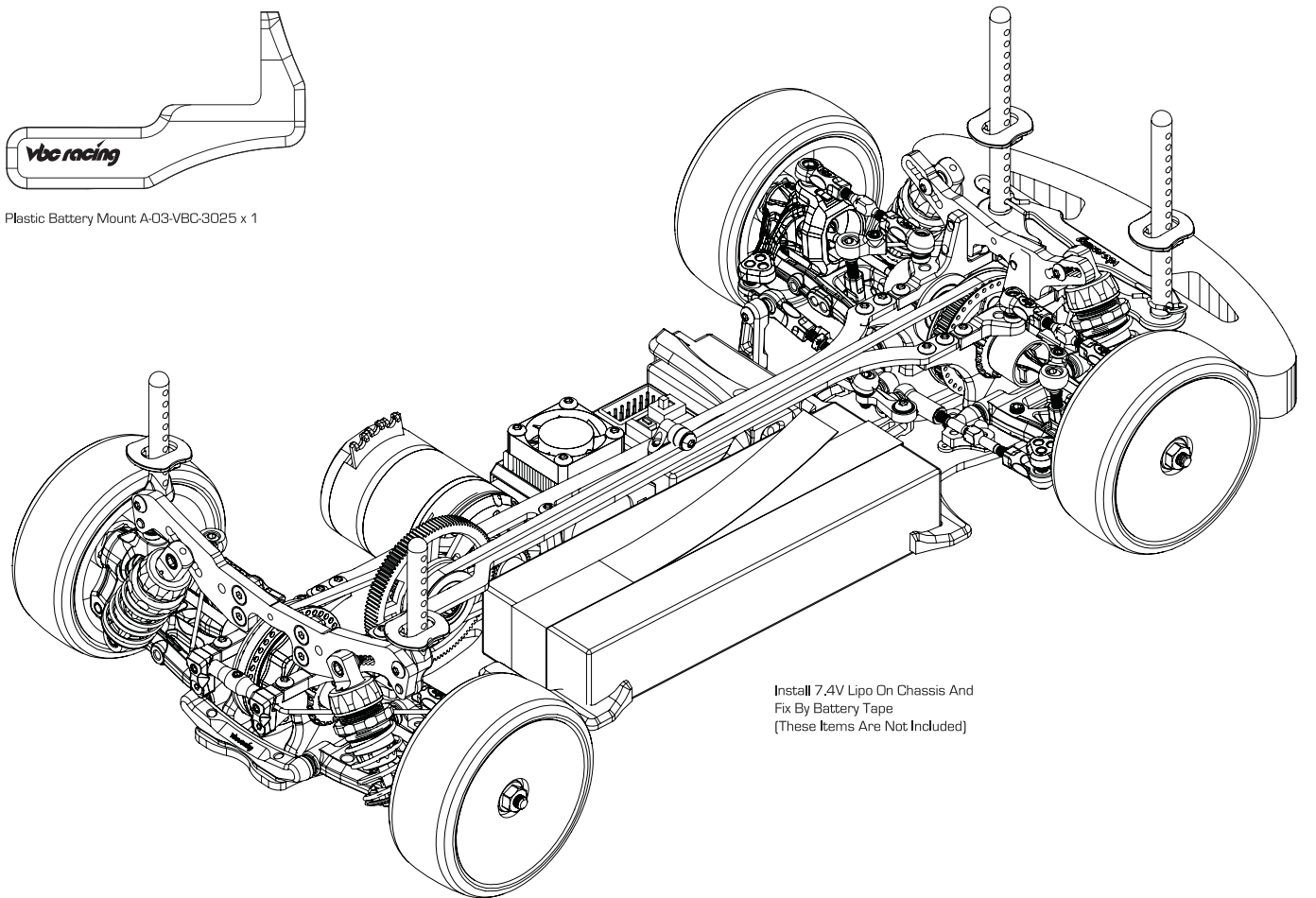
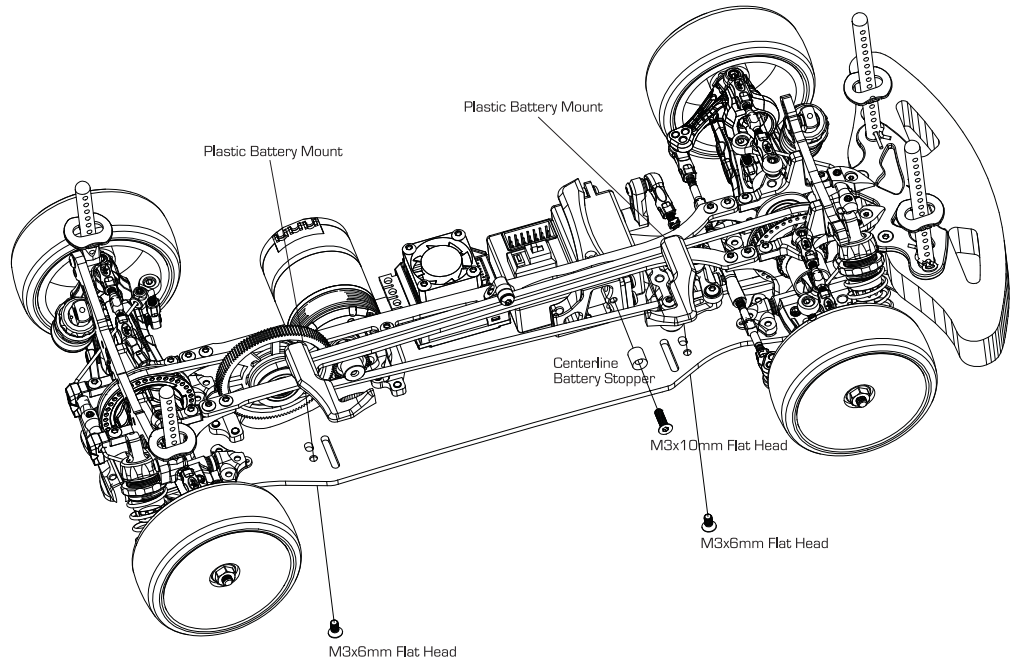

Install 7.4V Lipo On Chassis And
Fix By Battery Tape
(These Items Are Not Included)

Setting-Up



Shocks

TBB Shock Springs

All-newly designed "True Big Bore" shocks (TBB). Shorter shock shafts, bigger shock body diameter keeping the volume the same as original shocks. Shock top cap, shock body, shock bottom cap and height adjuster are made from aircraft grade aluminum. All new piston design groove to improve the linearity of oil flow. Optional different springs rate suitable for different track conditions.

VBC Racing TBB Shock Springs:
 TBB Shock Spring (Green - Soft) B-02-VBC-0136
 TBB Shock Spring (Red - Med. Soft) B-02-VBC-0134
 TBB Shock Spring (Orange - Med. Hard) B-02-VBC-0135
 TBB Shock Spring (White - Hard) B-02-VBC-0137

Color	Green B-02-VBC-00136	Red B-02-VBC-00134	Orange B-02-VBC-00135	White B-02-VBC-0137
Rate lb/in	13.30	14.40	16.20	17.10
Rate gf/mm	238	273.2	301.8	320
Coils	6.50	6.25	6.00	5.75

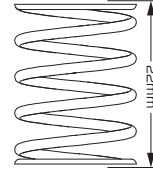

TBB Shock Pistons

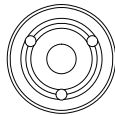

TBB Shock Piston (1.1mm x 3 holes)
A-03-VBC-0123 (STANDARD)

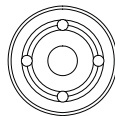

TBB Shock Piston (1.1mm x 4 holes)
A-03-VBC-0138 (OPTIONAL)

Additional markings on TBB piston as allow user drill more holes for difference damping setup

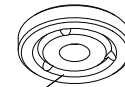
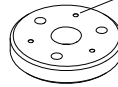

Piston groove to improve the linearity of oil flow

TBB Shock Shafts

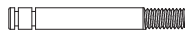

Titanium Coated Shock Shaft for TBB Shocks (4 pcs)
B-02-VBC-3031 (OPTIONAL)

TBB Oil Sealer Caps

4 Different Hardness Silicone Materials TBB Oil Sealer Cap Set
D-05-VBC-0095

Soft (Clear) B-03-VBC-0139
 Med Soft (Black) B-03-VBC-0132 (STANDARD)
 Med Hard (Blue) B-03-VBC-0141
 Hard (Red) B-03-VBC-0142

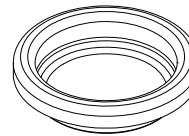

Suspension Mount Chart

Toe-angle of suspension arms are able to adjust by changing suspension mount. All of suspension mounts are made from aircraft grade aluminum. Selectable 20 different angles for front section and 33 different angles for rear section.

Suspension Mount List :

E10 Suspension Mount B-02-VBC-0061-10
 E15 Suspension Mount B-02-VBC-0061-15
 E20 Suspension Mount B-02-VBC-0061-20
 E25 Suspension Mount B-02-VBC-0061-25
 E30 Suspension Mount B-02-VBC-0061-30

F00 Suspension Mount B-02-VBC-0060-00
 F05 Suspension Mount B-02-VBC-0060-05
 F10 Suspension Mount B-02-VBC-0060-10

C00 Center Suspension Mount B-02-VBC-0062
 C05 Center Suspension Mount D-05-VBC-0065
 C10 Center Suspension Mount D-05-VBC-0061
 C15 Center Suspension Mount D-05-VBC-0068

FRONT SECTION SUSPENSION

		Narrow → Wide				
		E10	E15	F00	F05	F10
Narrow ↓	X-C15, Y-C15	-0.5	-1.0	-1.5	-2.0	-2.5
	X-C10, Y-C10	0.0	-0.5	-1.0	-1.5	-2.0
	X-C05, Y-C05		0.0	-0.5	-1.0	-1.5
	C0			0.0	-0.5	-1.0
	Y-C05, X-C05				0.0	-0.5
Wide ↓	Y-C10, X-C10					0.0
	Y-C15, X-C15					

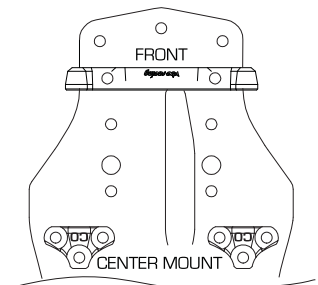

REAR SECTION SUSPENSION

		Narrow → Wide				
		E10	E15	E20	E25	E30
Narrow ↓	X-C15, Y-C15		0.0	0.5	1.0	1.5
	X-C10, Y-C10	0.0	0.5	1.0	1.5	2.0
	X-C05, Y-C05	0.5	1.0	1.5	2.0	2.5
	C0	1.0	1.5	2.0	2.5	3.0
	Y-C05, X-C05	1.5	2.0	2.5	3.0	3.5
Wide ↓	Y-C10, X-C10	2.0	2.5	3.0	3.5	4.0
	Y-C15, X-C15	2.5	3.0	3.5	4.0	

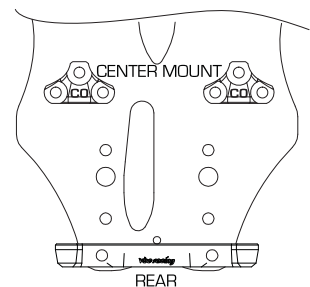



www.vbcrcing.com



COMPETITION GRADE HIGH PERFORMANCE RADIO CONTROL RACING CAR CHASSIS KIT

WILDFIRE D07

1/10 4WD ELECTRIC COMPETITION TOURING CAR KIT

Instruction Book VBC Racing WildFire D07 Touring Car Kit D-05-VBC-CK07