

WILDFIRE DO6

1/10 4WD ELECTRIC COMPETITION TOURING CAR KIT



SETUP SHEET

DRIVER _____	DATE _____
TRACK NAME _____	RESULT _____
COMPOSITION _____	(INDOOR/OUTDOOR) BEST LAP _____
HUMIDITY _____	TRACK TEMP _____
GRIP HI MEDIUM LOW _____	SURFACE SMOOTH BUMPY _____

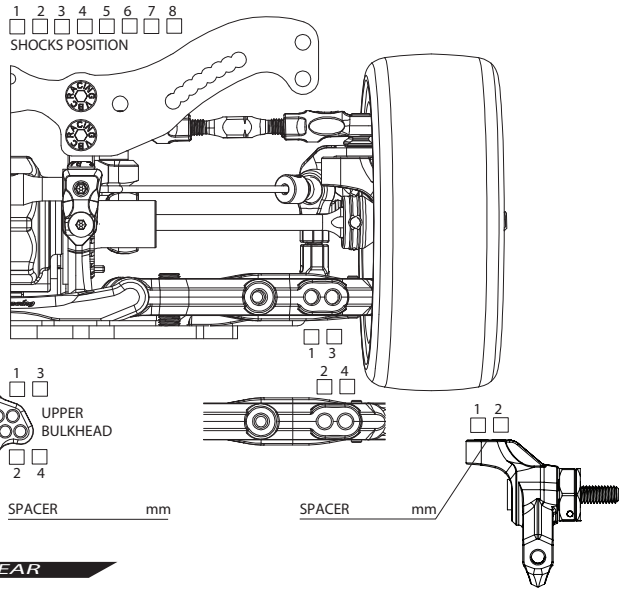
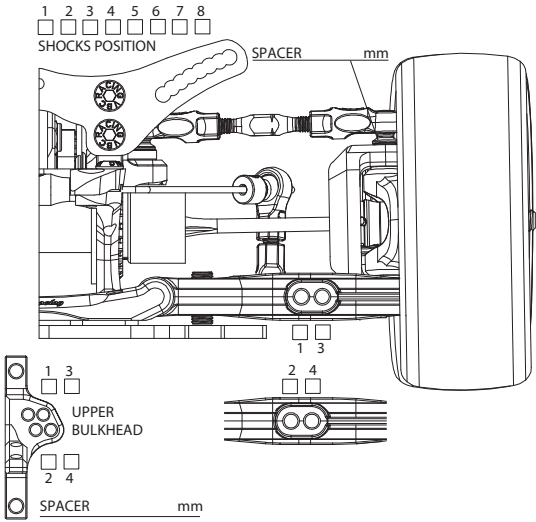

FRONT

GROUND CLEARANCE mm DROOP _____

CAMBER ANGLE ° TOE ANGLE _____ °

CASTER BLOCK ° FRONT DRIVE DIFF (OIL) / DIRECT _____

STABILIZER 1.2 1.3 1.4 WHEEL SPACER mm _____

SUSPENSION SHIM (FF) mm SUSPENSION SHIM (FR) mm _____

SUSPENSION MOUNT (FF) _____ SUSPENSION MOUNT (FR) _____

WHEELBASE FRONT REAR BELT TENSION _____

AXLE TYPE / SIZE TWO PIECE JOINT / SINGLE JOINT (STEEL/ALUM) mm _____

REAR

GROUND CLEARANCE mm DROOP _____

CAMBER ANGLE ° TOE ANGLE _____ °

REAR DRIVE DIFF (OIL) DRIVE CUP ALUMINUM/STEEL _____

STABILIZER 1.2 1.3 1.4 WHEEL SPACER mm _____

SUSPENSION SHIM (RF) mm SUSPENSION SHIM (RR) mm _____

SUSPENSION MOUNT (RF) _____ SUSPENSION MOUNT (RR) _____

WHEELBASE FRONT REAR BELT TENSION _____

AXLE TYPE / SIZE TWO PIECE JOINT / SINGLE JOINT (STEEL/ALUM) mm _____

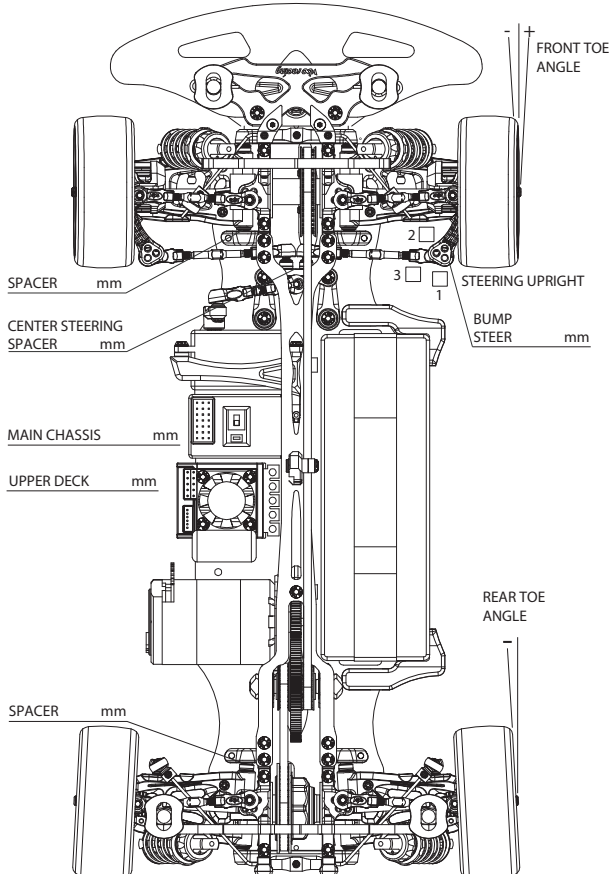

FRONT

SHOCK LENGTH mm _____

PISTON 3 4 holes / OTHERS _____

OIL _____

SPRING _____

OIL SEALER CAP S / MS / M / H _____

REBOUND % _____

NOTES _____

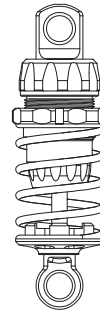

REAR

SHOCK LENGTH mm _____

PISTON 3 4 holes / OTHERS _____

OIL _____

SPRING _____

OIL SEALER CAP S / MS / M / H _____

REBOUND % _____

NOTES _____

MOTOR _____ SPUR T _____ PINION T PITCH _____

TIRE _____ TIRE INSERT _____ WHEEL _____

TIRE ADDICTIVE _____ TIME _____ TIRE WARMER _____

ESC _____ ESC SETTING _____

BATTERY _____ BODY _____ REAR WING _____

REMARKS _____
