

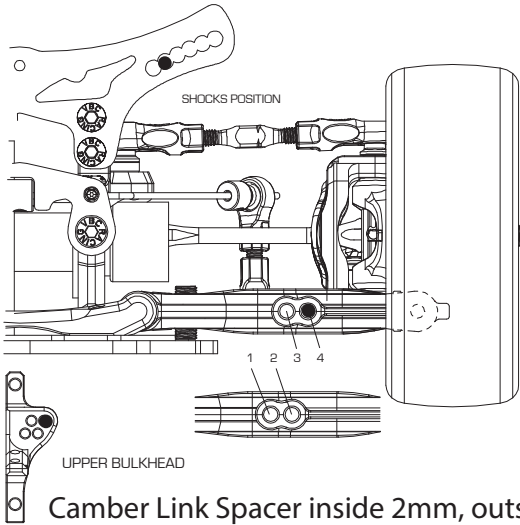

1/10 4WD ELECTRIC COMPETITION TOURING CAR KIT

SETUP SHEET

DRIVER	Ray Poon	DATE	27 Jan 2013
TRACK NAME	Multi Top Race, TRC, HK	RESULT	13.5T TQ & Win
TRACK SURFACE	Asphalt	GRIP CONDITION	HI (MED) LOW
HUMIDITY		TRACK TEMP	



Camber Link Spacer inside 2mm, outside 0mm

FRONT

GROUND CLEARANCE	4.5	mm	REBOUND	50%		
CAMBER ANGLE	2.5	°	TOE ANGLE	-0.5		
CASTER BLOCK	STD		FRONT DRIVE DIFF (OIL )	DIREC		
STABILIZER	1.2	1.3	1.4	WHEEL SPACER	0	mm
FRONT SUSPENSION MOUNT SHIM	0.5	mm	REAR SUSPENSION MOUNT SHIM	0.5	mm	
FRONT SUSPENSION MOUNT	F05		REAR SUSPENSION MOUNT	C0		
DOWNSTOP	7	mm				

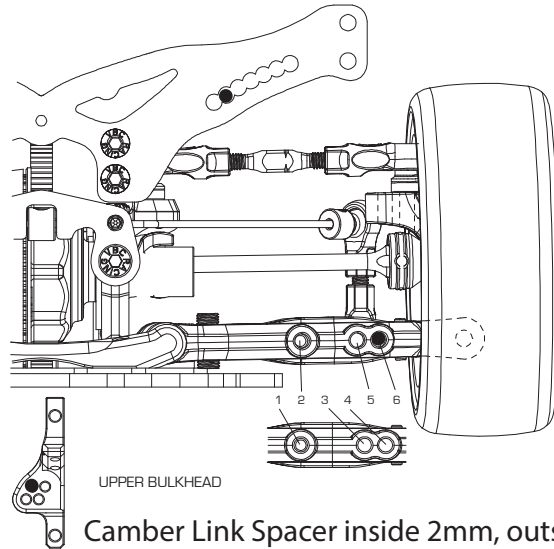

Camber Link Spacer inside 2mm, outside 2.5mm

REAR

GROUND CLEARANCE	5	mm	REBOUND	50%		
CAMBER ANGLE	-2	°	TOE ANGLE	2.5		
FRONT DRIVE DIFF (OIL )	10000					
STABILIZER	1.2	1.3	1.4	WHEEL SPACER		mm
FRONT SUSPENSION MOUNT SHIM	0.5	mm	REAR SUSPENSION MOUNT SHIM	0.5	mm	
FRONT SUSPENSION MOUNT	C0		REAR SUSPENSION MOUNT	E25		
DOWNSTOP	6	mm				

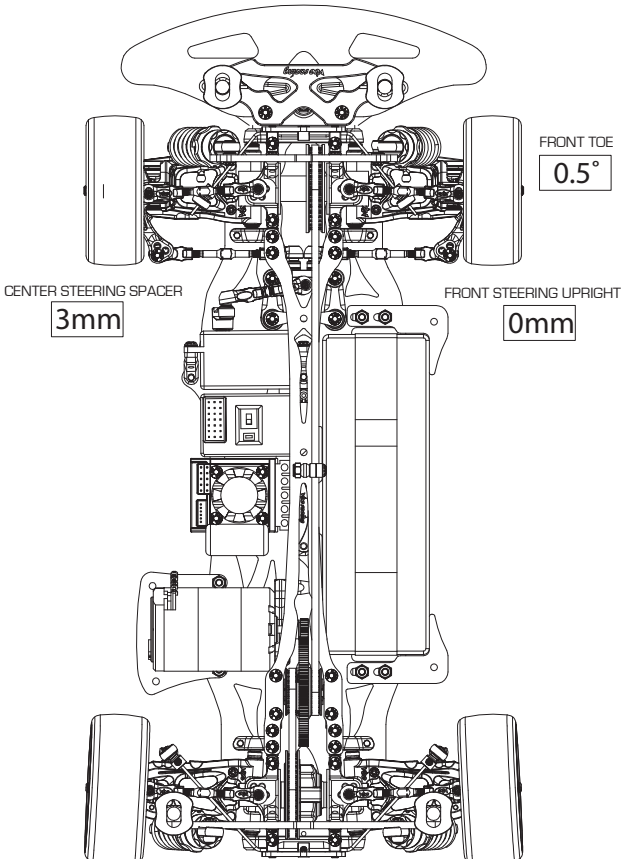

FRONT

SHOCK LENGTH	68.3mm
PISTON	1 2 3 hole(s)
OIL	AE#35
SPRING	HPI Blue



REAR

SHOCK LENGTH	68.3mm
PISTON	1 2 3 hole(s)
OIL	AE#35
SPRING	HPI Blue

MOTOR	Orca RX2 13.5T	SPUR	108T	PINION	34T
TIRE	Panaracer	TIRE INSERT	Panaracer	WHEEL	Panaracer
TIRE ADDITIVE		BODY	PF LTC-R	BATTERY	
REMARKS	Standard Chassis and standard upper deck				

---



---



---



---



---