

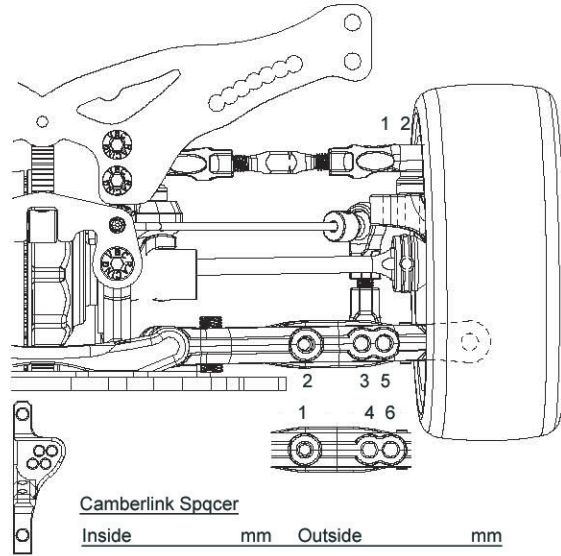

1/10 4WD ELECTRIC COMPETITION TOURING CAR KIT

SETUP SHEET

Driver	Date
Track	Event
Indoor - Outdoor	Asphalt - Carpet
Bumpy - Smooth	Low - Medium - High
Open - Tight	Fast - Mixed - Technical
Humidity %	Air Temp °
	Track Temp °

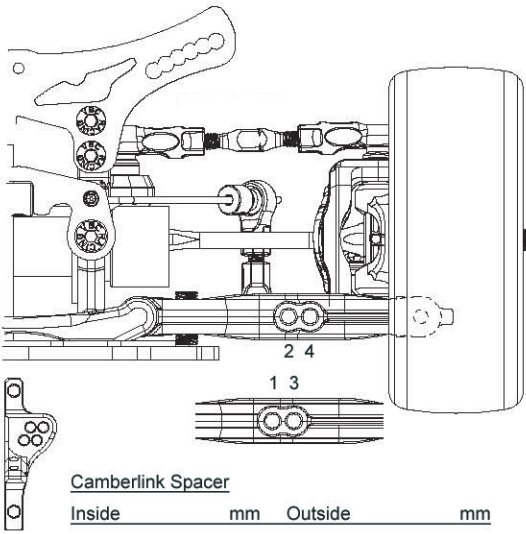

Front

Ground Clearance	mm	Rebound	mm
Camber angle	°	Toe Angle	°
Caster Block	°	Front Drive	
Stabilizer 1.2 1.3 1.4		Wheel Spacer	mm
Front Susp Mount Shim	mm	Front Susp Mount Shim	mm
Front Susp Mount		Front Susp Mount	
Bell Tension		Comments	

Rear

Ground Clearance	mm	Rebound	mm
Camber angle	°	Toe Angle	°
Rear Drive			
Stabilizer 1.2 1.3 1.4		Wheel Spacer	mm
Front Susp Mount Shim	mm	Front Susp Mount Shim	mm
Front Susp Mount		Front Susp Mount	
Bell Tension		Comments	

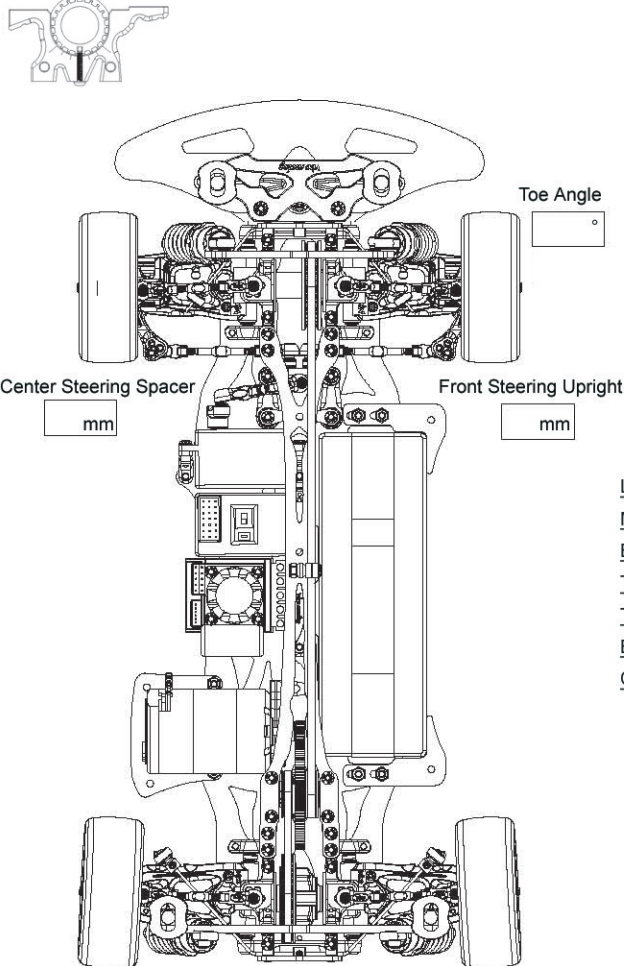

Front

Brand	
Piston	
Oil	
Spring	
Limiter	
Comments	



Rear

Brand	
Piston	
Oil	
Spring	
Limiter	
Comments	

Lower Desk	Top Desk		
Motor	Spur	Pinion	Ratio
ESC	ESC setting		
Tire	Insert	Wheel	
Tire Additive	Time	Min	Tire Warmer Yes No Time min
Body	Wing	Battery	
Comments			