



1/10 4WD ELECTRIC COMPETITION TOURING CAR KIT

SETUP SHEET



DRIVER	DATE		
TRACK <b>earcc</b>	RESULT		
ASPHALT / CARPET	INDOOR / OUTDOOR	BEST LAP	
HUMIDITY	TRACK TEMP	AIR TEMP	
GRIP LOW MEDIUM HIGH	SURFACE BUMPY MEDIUM SMOOTH		

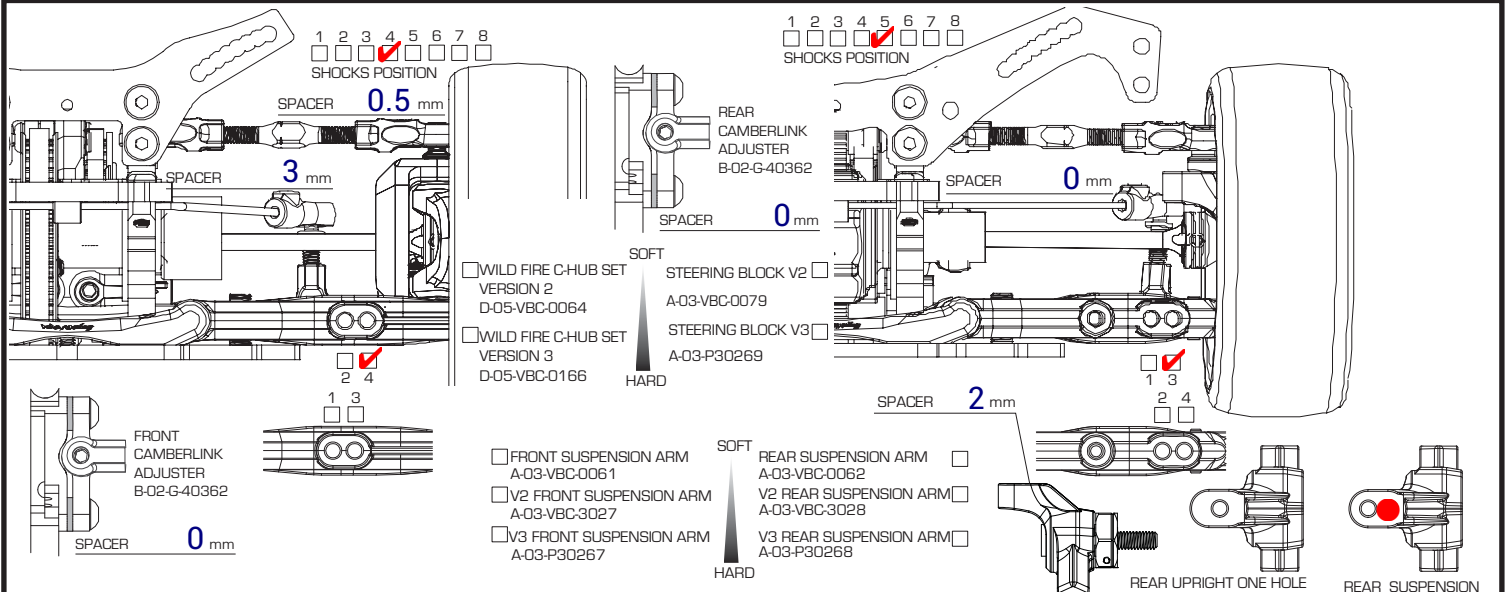

**FRONT**

GROUND CLEARANCE **5 mm** DROOP **9.5 centre of pin**

CAMBER ANGLE **1 °** TOE ANGLE **0**

CASTER BLOCK **kit** FRONT DRIVE DIFF (OIL ) / DIRECT

STABILIZER 1.2  1.3  WHEEL SPACER **0 mm**

SUSPENSION SHIM (FF) **0.5 mm** SUSPENSION SHIM (FR) **0.5 mm**

SUSPENSION MOUNT (FF) **F0** SUSPENSION MOUNT (FR) **c05 split**

AXLE TYPE / SIZE TWO-PIECE JOINT / SINGLE JOINT (STEEL/ALUM) mm

**REAR**

GROUND CLEARANCE **5.5 mm** DROOP **10.5 to centre of pin**

CAMBER ANGLE **2 °** TOE ANGLE **3**

REAR DRIVE DIFF (OIL **6000**) DRIVE CUP **ALUMINUM** / STEEL

STABILIZER 1.2  1.4 WHEEL SPACER mm

SUSPENSION SHIM (RF) **0.5 mm** SUSPENSION SHIM (RR) **0.5 mm**

SUSPENSION MOUNT (RF) **C0 split** SUSPENSION MOUNT (RR) **E30**

AXLE TYPE / SIZE TWO-PIECE JOINT / SINGLE JOINT (STEEL/ALUMINUM) mm

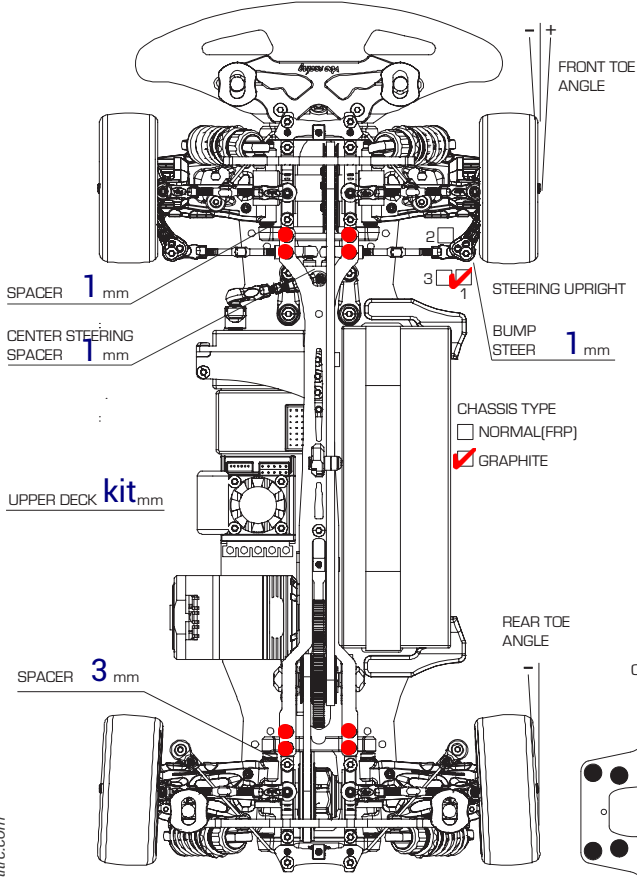

<b>FRONT</b>	<b>SHOCK LENGTH</b> mm	<b>REAR</b>	<b>SHOCK LENGTH</b> mm
<b>PISTON</b> <input checked="" type="checkbox"/> 4 hole(s) / OTHERS		<b>PISTON</b> <input checked="" type="checkbox"/> 4 hole(s) / OTHERS	
<b>OIL</b> <b>500cst</b>		<b>OIL</b> <b>550cst</b>	
<b>SPRING</b> <b>yokomo pink</b>		<b>SPRING</b> <b>yokomo blue</b>	
<b>OIL SEALER CAP</b> S / MS / M / H		<b>OIL SEALER CAP</b> S / MS / M / H	
<b>REBOUND</b> <b>2mm rebound</b> %		<b>REBOUND</b> <b>2mm rebound</b> %	
<b>NOTES</b>		<b>NOTES</b>	
<b>MOTOR</b> SPUR T	<b>PITCH</b>	<b>PINION</b> T	
<b>TIRE</b>	<b>TIRE INSERT</b>	<b>WHEEL</b>	
<b>TIRE ADDITIVE</b>	<b>BODY</b>	<b>REAR WING</b>	
<b>ESC</b>	<b>BATTERY</b>		
<b>REMARKS</b>	<b>rear inner camber link kit front optional rear hole</b>		

Chassis Flex Settin (Fill in the Circle)

