



1/10 4WD ELECTRIC COMPETITION TOURING CAR KIT

SETUP SHEET



TRACK	Tenerife (Santa ursula)	RESULT	3^o
ASPHALT / CARPET	INDOOR / OUTDOOR	BEST LAP	16.8
HUMIDITY	TRACK TEMP	AIR TEMP	
GRIP LOW MEDIUM HIGH	SURFACE BUMPY MEDIUM SMOOTH		

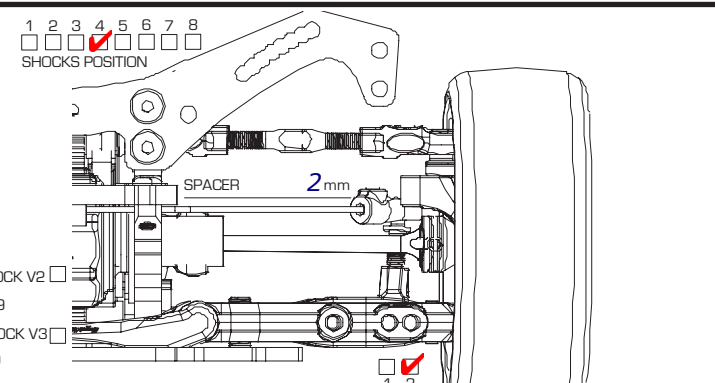
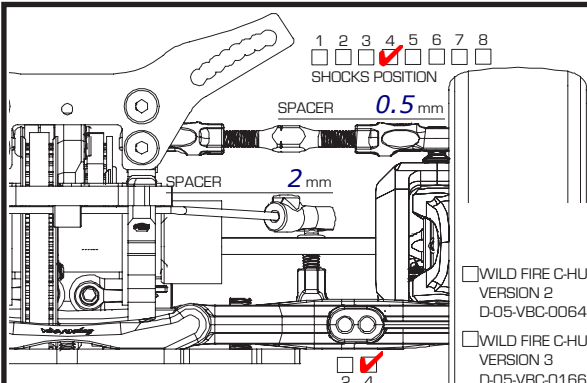

FRONT

GROUND CLEARANCE	5.2 mm	DROOP	5
CAMBER ANGLE	2°	TOE ANGLE	
CASTER BLOCK		FRONT DRIVE DIFF (OIL) / DIRECT	<input checked="" type="checkbox"/>
STABILIZER	1.2 <input checked="" type="checkbox"/> 1.4	WHEEL SPACER	mm
SUSPENSION SHIM (FF)	0.5 mm	SUSPENSION SHIM (FR)	0.5 mm
SUSPENSION MOUNT (FF)	F00	SUSPENSION MOUNT (FR)	C05 (In)
AXLE TYPE / SIZE	TWO-PIECE JOINT / SINGLE JOINT (STEEL/ALUM) mm		

REAR

GROUND CLEARANCE	5.4 mm	DROOP	0.5
CAMBER ANGLE	1.5°	TOE ANGLE	
REAR DRIVE	DIFF (OIL 3000)	DRIVE CUP	ALUMINUM / STEEL
STABILIZER	1.2 <input checked="" type="checkbox"/> 1.4	WHEEL SPACER	mm
SUSPENSION SHIM (RF)	0 mm	SUSPENSION SHIM (RR)	0 mm
SUSPENSION MOUNT (RF)	C05 (Out)	SUSPENSION MOUNT (RR)	E30
AXLE TYPE / SIZE	TWO-PIECE JOINT / SINGLE JOINT (STEEL/ALUMINUM) mm		

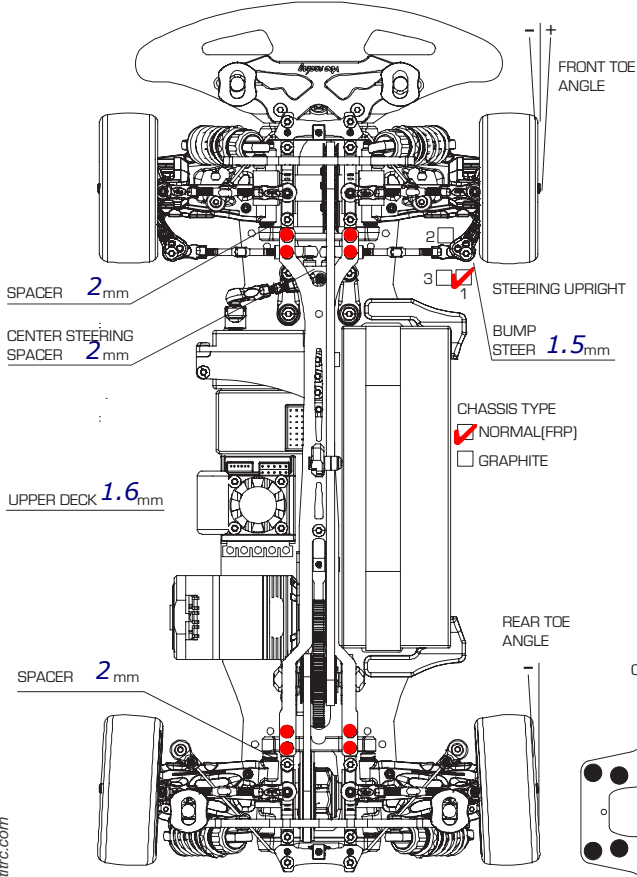

FRONT

SHOCK LENGTH	BB Short mm
PISTON	<input checked="" type="checkbox"/> 4 hole(s) / OTHERS
OIL	450
SPRING	2.5 Xray
OIL SEALER CAP	S / MS / <input checked="" type="checkbox"/> H
REBOUND	25 %
NOTES	

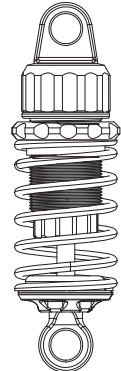

REAR

SHOCK LENGTH	BB Short mm
PISTON	<input checked="" type="checkbox"/> 4 hole(s) / OTHERS
OIL	450
SPRING	2.5-2.8 Xray (Progressive)
OIL SEALER CAP	S / MS / <input checked="" type="checkbox"/> H
REBOUND	25 %
NOTES	

MOTOR	5.0 MM	SPUR	113 T	PITCH	64	PINION	31 T
TIRE	Ride 34	TIRE INSERT		WHEEL			
TIRE ADDICTIVE	MR33	BODY	Nardo	REAR WING	MR33		
ESC	Fleta Pro	BATTERY	MM Stock spec				
REMARKS	Shocks and shock tower of D07!						

Chassis Flex Settin (Fill in the Circle)

