



1/10 ELECTRIC COMPETITION FORMULA CAR KIT

Setting Sheet

Ver 1.01



Driver : Default Setup Track : _____

Date : _____ Condition : _____

Event : _____ Temp. : _____

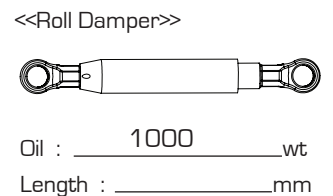
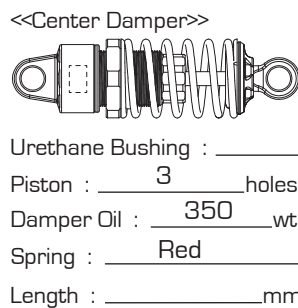
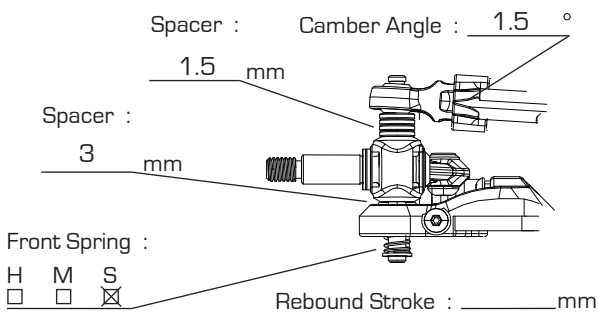
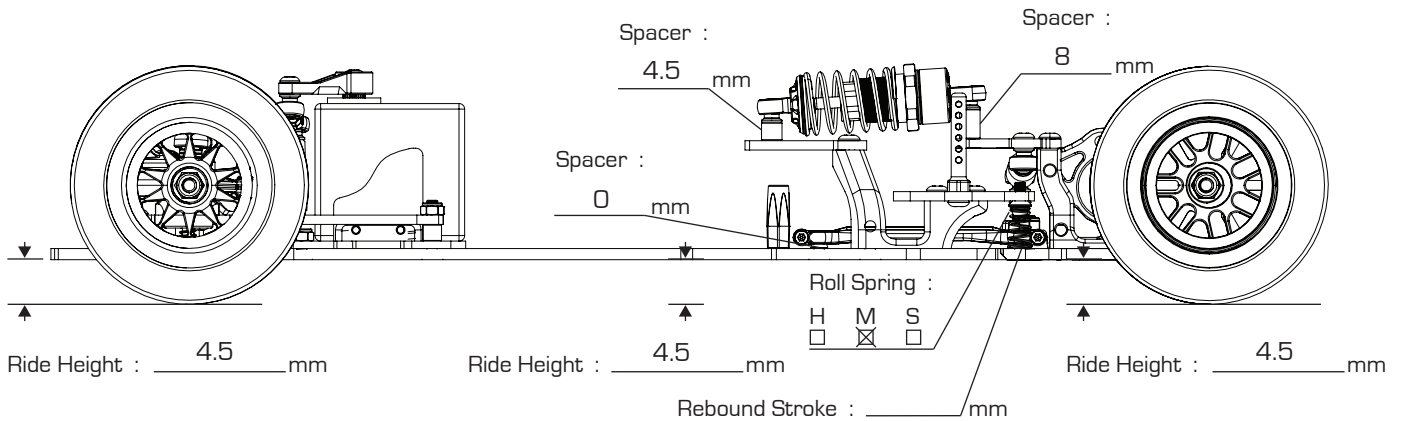
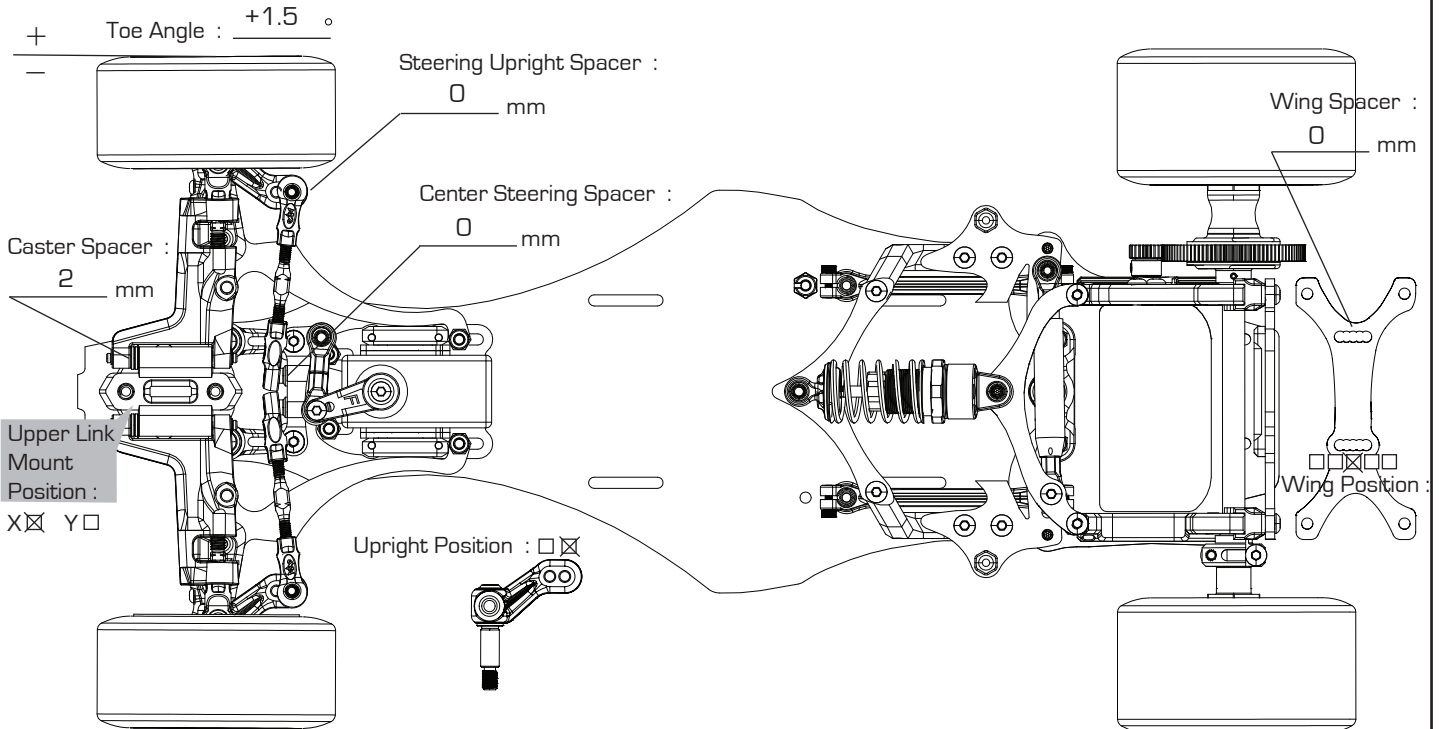

Motor : _____ Body : _____
 Spur Gear : _____ T Front Wing : _____
 Pinon Gear : _____ T Rear Wing : _____
 Gear Ratio : _____ T Tire : _____
 ESC : _____ Insert : _____
 Setup : _____ Wheel : _____
 Battery : _____ Treatment : _____
 Weight : _____ Diameter : FR _____ mm, RR _____ mm

